

HOOK DIMENSIONS

HAND CHAIN HOISTS

Capacity (Tonnes)	Dimensions (mm)				
	A	B	C	D	E
0.454	16	73	20	36	27
0.907	20	86	24	40	28
1.814	24	113	30	50	35
2.722	28	133	42	54	41
4.536	36	152	46	61	44
6.804	42	185	66	71	43
9.072	62	236	90	80	52
13.608	65	270	90	110	60
18.144	79	323	118	120	85

LEVER HOISTS

Capacity (Tonnes)	Dimensions (mm)				
	A	B	C	D	E
0.680	15	74	19	36	23
1.361	22	103	28	43	28
1.814	24	113	31	47	28
2.722	32	126	35	53	34
5.443	37	152	45	62	46
8.165	54	236	84	90	56

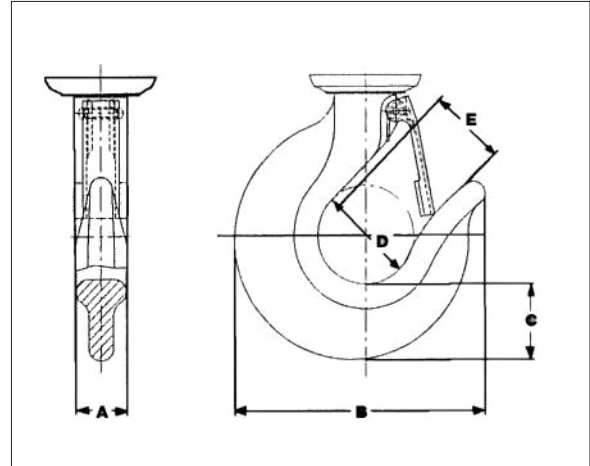

OPTIONS FOR HAND CHAIN HOISTS

Bronze wheels, nickel plated trolley and hoist body, nickel plated hand and load chain, bronze coated hook and load block.



Bronze wheels, bronze load hook and stainless steel load chain.



Stainless steel load chain, bottom block and hook.



Chain container.

