

Crosby LEBUS A-1W

- Forged steel – Quenched & Tempered.
- Used as a come-a-long for short take-up on chain.
- Binder toggles away from the load.
- Binders shown with Proof Loads have been individually proof tested to values shown, prior to shipment.
- Meets or exceeds requirements of US DOT FMCSA Part 393 Subpart I.

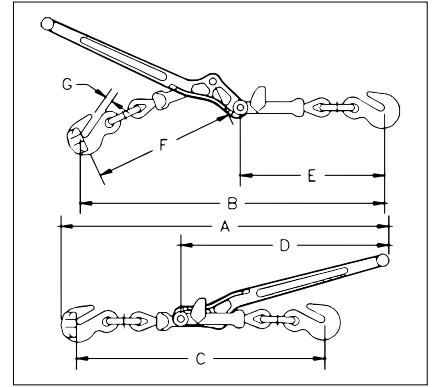

APPLICATION AND WARNING INFORMATION
SECTION 17

Crosby LEBUS A-1W Walking Load Binders

Model	Stock No.	Chain Size (mm)	Working Load Limit (t)	Proof Load (kN)	Ultimate Load (t)	Weight Each (kg)	Handle Length (mm)	Dimensions (mm)						
								A	B	C	D	E	F	G
A-1W	1048388	13 only	4.17	82	15.0	5.94	475	730	654	540	475	313	314	16.0