

Crosby LEBUS L-150

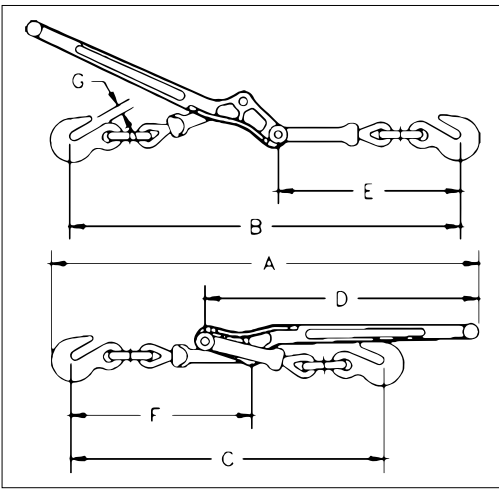

APPLICATION AND WARNING INFORMATION
SECTION 17

- Extra heavy construction at leverage point to prevent spreading. Heel of binder toggles away from load, permitting easy release.
- Ball and socket swivel joints at hook assemblies permit a straight line pull.
- Binders shown with Proof Loads have been individually proof tested to values shown, prior to shipment.
- Forged steel – Quenched & Tempered.
- Meets or exceeds requirements of US DOT FMCSA Part 393 Subpart I.

Crosby LEBUS L-150 Standard Lever Type Load Binders

Model	Stock No.	Std. Pkg.	Min-Max Chain Size (mm)	Working Load Limit (t)	Proof Load (kN)	Ultimate Load (t)	Weight Each (kg)	Handle Length (mm)	Take Up (mm)	Dimensions (mm)						
										A	B	C	D	E	F	G
7-1	1048128	4	8 - 10	2.45	48	8.63	3.18	406	114	613	562	454	406	264	264	12.7
A-1	1048146	4	10 - 13	4.17	82	15.0	5.66	475	114	730	654	540	475	313	314	16.0
C-1	1048164	4	13 - 16	5.90	116	20.9	8.93	533	121	794	756	635	533	372	349	18.3