

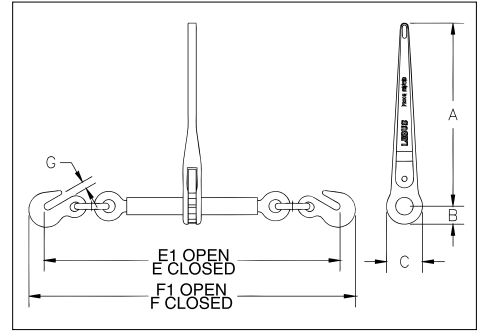

Crosby LEBUS L-140



Load Tested

APPLICATION AND WARNING INFORMATION
SECTION 17

- Upgraded for use with Grades 70, 80 and 100 Chain.
- Utilizes standard Crosby A-323 Alloy Eye Grab Hooks.
- New design one piece forged handle.
- Continuous take-up feature provides finite adjustment to tie down load.
- One piece assembly, no bolts or nuts to loosen.
- Ratchet spring is rust proofed.
- All load bearing or holding parts forged.
- Easy operating positive ratchet.
- Binders shown with Proof Loads have been individually proof tested to values shown, prior to shipment.
- Meets or exceeds requirements of US DOT FMCSA Part 393 Subpart I.
- Matches the Working Load Limit of Grade 100 chain except for 16mm size.

Crosby LEBUS L-140 Standard Ratchet Type Load Binders

Model	Stock No.	Min-Max Chain Size (mm)	Working Load Limit (t)	Proof Load (kN)	Weight Each (kg)	Handle Length (mm)	Barrel Length (mm)	Take Up (mm)	Dimensions (mm)							
									A	B	C	E	E1	F	F1	G
R-7	1048404	8 - 10	3.99	79	5.49	356	254	203	356	35.1	70.0	583	786	638	842	12.7
R-A	1048422	10 - 13	6.80	134	6.66	356	254	203	356	35.1	70.0	641	845	702	905	16.0
R-C	1048440	13 - 16	7.26	143	6.60	356	254	203	356	35.1	70.0	670	873	748	951	18.3

3:1 Design Factor.

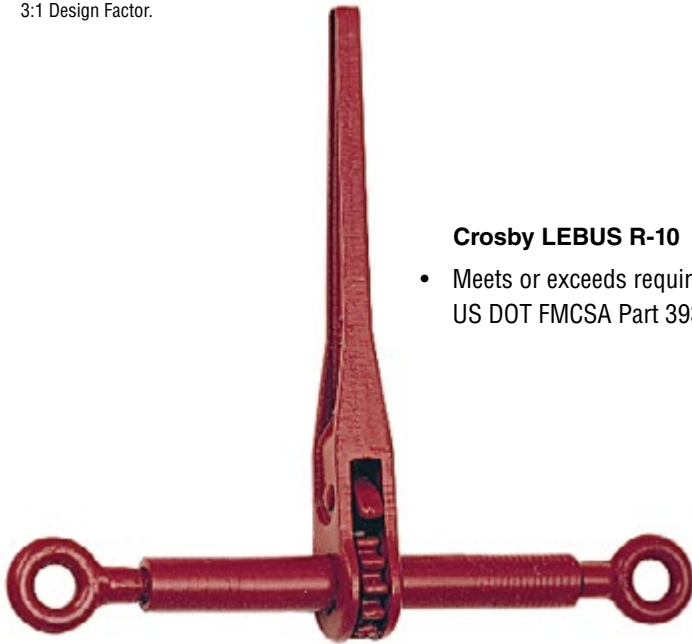

Crosby LEBUS R-10

- Meets or exceeds requirements of US DOT FMCSA Part 393 Subpart I.

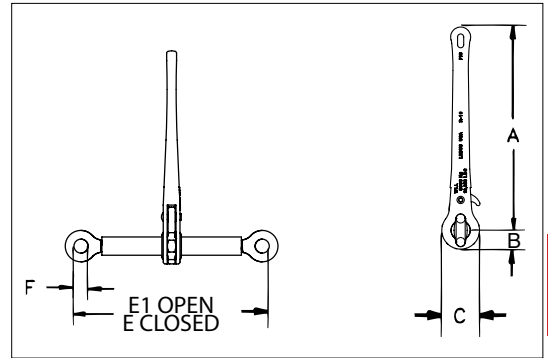

13

Crosby LEBUS R-10 Binder without Links and Hooks

Model	Stock No.	Working Load Limit (t)	Weight Each (kg)	Handle Length (mm)	Barrel Length (mm)	Take Up (mm)	Dimensions (mm)					
							A	B	C	E	E1	F
R-10	1048468	7.26	3.65	356	254	203	356	35.1	70.0	356	559	25.4

3:1 Design Factor.