

S-264

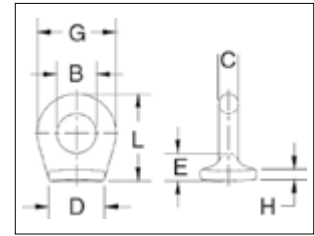

- Forged steel - Quenched & Tempered.
- Forged from 1035 carbon steel.
- Excellent welding qualities.
- Widely used on farm machinery, trucks, steel hulled marine vessels and material handling equipment.
- Reference American Welding Society specifications for proper welding procedures.



S-264 Pad Eyes

Size No.	Stock No.	Weight Per 100 (kg)	Dimensions (mm)						
			B	C	D	E	G	H	L
* 0	1090722	1.27	6.35	4.85	16.0	7.85	16.0	2.30	19.1
* 1	1090740	2.95	9.65	6.35	22.4	10.4	22.4	3.30	26.2
* 1-1/2	1090768	4.72	16.0	6.35	25.4	11.2	28.7	4.05	33.3
2	1090786	9.57	19.1	9.65	26.9	12.7	38.1	4.85	41.4
4	1090802	23.7	25.4	14.2	36.6	19.8	54.0	5.60	59.5
5	1090820	37.4	31.8	17.5	44.5	20.6	67.0	6.35	70.0

*Meets the requirements of Military Specification MS-51930A.

G-400



- Forged steel - Quenched & Tempered.
- Hot-dip Galvanized
- Tapped with standard UNC class 2 threads after galvanizing.
- Also available in blank (as forged) item (S-4028).
- Meets or exceeds all requirements of ASME B30.26.

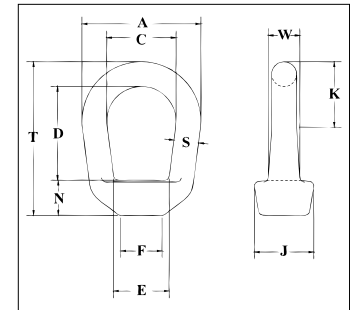

G-400 Eye Nuts

Size No.	"S" Stock Size (mm)	Stock No	Std. Tap Size (in)	Working Load Limit (t)	Weight Each (kg)	Dimensions (mm)									
						A	C	D	E	F	J	K	N	T	W
1	6.35	1090438	1/4	.24	.04	31.8	19.1	25.4	19.1	12.7	17.5	16.0	9.65	43.7	7.85
2	7.85	1090474	3/8	.57	.08	41.1	25.4	30.5	21.1	14.2	20.6	22.6	12.7	53	10.4
3A	9.65	1090517	1/2	1.02	.13	51.0	31.8	36.6	27.4	20.6	25.4	27.7	15.7	63.5	12.7
4	12.7	1090535	5/8	1.63	.27	63.5	38.1	48.8	34.3	25.4	33.3	33.3	17.5	82.5	17.5
5	16	1090553	3/4	2.36	.45	76.0	44.5	60.5	40.4	28.4	38.1	39.9	22.4	98.8	21.3
6	19.1	1090571	7/8	3.27	.75	89.0	51.0	66.8	49.8	35.1	47.8	45.0	23.9	110	25.4
7	22.4	1090599	1	4.54	1.22	102	57.0	77.7	56.0	39.6	54.0	51.5	27.2	127	30.2
8	25.4	1090633	1-1/4	7.03	1.98	114	63.5	88.9	62.5	47.8	60.5	57.5	31.8	147	35.1
9	28.7	1090651	1-3/8	8.39	2.27	127	70.0	102	68.5	51.0	65.0	64.5	35.1	165	38.1
10	31.8	1090679	1-1/2	10.21	3.08	143	79.0	109	78.5	57.0	76.0	71.5	38.1	179	42.2
11	38.1	1090697	2	18.14	6.62	181	104	157	104	79.5	95.5	93.5	52.3	252	49.3

5:1 Design Factor. Working Load Limit shown is for In-Line pull. Rating based on standard tap size.