

## G-416 / S-416

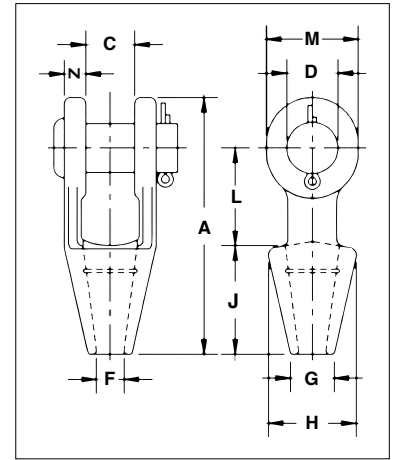

- Forged steel sockets through 38mm, cast alloy steel 40mm through 102mm.
- Spelter socket terminations have an efficiency rating of 100%, based on the catalog strength of wire rope.
- Ratings are based on recommended use with 6 x 7, 6 x 19 or 6 x 37, IPS or XIP (EIP), XXIP (EEIP), RRL, FC or IWRC wire rope.
- Strand constructed with minimal number of wires (e.g. 1 x 7) requires special consideration that socket basket length be five (5) times the strand diameter or fifty (50) times the wire diameter, whichever is the greater.
- All cast steel sockets 40mm and larger are magnetic particle inspected and ultrasonic inspected. Proof testing available on special order.
- Available with bolt nut and cotter: G-416B.
- Open Grooved Sockets meet the performance requirements of Federal Specification RR-S-550F, Type A, except for those provisions required of the contractor.



## G-416 / S-416 Open Spelter Sockets

Rope Dia.		Structural Strand Dia. (mm)	Ultimate Load (t)	Stock No.		Weight Each (kg)	Dimensions (mm)										Tolerance +/- (mm)
(in)	(mm)			G-416 Galv.	S-416 S.C.		A	B	C	D	E	F	G	H	J	K	
5/16-3/8	8-10	—	12	1039637	1039646	.59	123	20.6	20.6	12.7	20.6	42.9	57.0	44.5	38.1	11.2	1.52
7/16-1/2	11-13	—	20	1039655	1039664	1.02	141	25.4	25.4	14.2	23.9	47.8	63.5	51.0	47.8	12.7	1.52
9/16-5/8	14-16	12-13	27	1039673	1039682	1.63	171	31.8	30.2	17.5	28.7	57.0	76.0	63.5	57.0	14.2	1.52
3/4	18	14-16	43	1039691	1039708	2.64	202	38.1	35.1	20.6	31.8	66.5	89.0	76.0	66.5	15.7	1.52
7/8	20-22	18-19	55	1039717	1039726	4.38	235	44.5	41.4	23.9	38.1	82.5	102	89.0	79.5	20.3	1.52
1	24-26	20-22	78	1039735	1039744	7.03	268	51.0	51.0	28.7	44.5	95.5	114	102	95.5	22.4	1.52
1-1/8	28-30	24-26	92	1039753	1039762	9.75	300	57.0	57.0	31.8	51.0	105	127	117	105	25.4	3.05
1-1/4 - 1-3/8	32-35	28	136	1039771	1039780	14.1	335	63.5	63.5	38.1	57.0	121	140	127	121	28.7	3.05
1-1/2	38	30-32	170	1039799	1039806	21.4	384	76.0	70.0	41.4	70.0	133	152	152	137	30.2	3.05
* 1-5/8	* 40-42	33-35	188	1039815	1039824	24.9	413	76.0	76.0	44.5	76.0	140	165	165	146	33.3	3.05
* 1-3/4 - 1-7/8	* 44-48	36-40	268	1039833	1039842	37.2	464	89.0	89.0	51.0	79.5	162	191	178	165	39.6	3.05
* 2 - 2-1/8	* 50-54	42-45	291	1039851	1039860	59	546	102	95.5	57.0	95.5	187	216	229	178	46.0	3.05
* 2-1/4 - 2-3/8	* 56-60	46-48	360	1039879	1039888	76	597	114	108	63.5	102	210	229	254	197	54.0	3.05
* 2-1/2 - 2-5/8	* 64-67	50-54	424	1041633	1041642	114	648	127	121	73.0	114	235	248	274	216	60.5	3.05
* 2-3/4 - 2-7/8	* 70-73	56-62	511	1041651	1041660	143	692	133	127	79.0	124	267	279	279	229	73.0	6.35
* 3 - 3-1/8	* 75-80	64-67	563	1041679	1041688	172	737	146	133	86.0	133	282	305	287	241	76.0	6.35
* 3-1/4 - 3-3/8	* 82-86	70-73	722	1041697	1041704	197	784	159	140	92.0	146	302	330	300	254	79.0	6.35
* 3-1/2 - 3-5/8	* 88-92	76-80	779	1041713	1041722	255	845	171	152	98.5	165	314	356	318	274	82.5	6.35
* 3-3/4 - 4	* 94-102	—	875	1041731	1041740	355	921	191	178	108	184	346	381	343	318	89.0	6.35

\* Cast alloy steel.