

HOOK DIMENSIONS

HAND CHAIN HOISTS

Capacity (Ton)	Dimensions (in)				
	A	B	C	D	E
1/2	0.63	2.87	0.79	1.42	1.08
1	0.79	3.39	0.94	1.57	1.12
2	0.94	4.45	1.18	1.97	1.38
3	1.10	5.24	1.65	2.13	1.61
5	1.42	5.98	1.81	2.40	1.73
7 1/2	1.65	7.28	2.60	2.80	1.69
10	2.44	9.29	3.54	3.15	2.03
15	2.56	10.63	3.54	4.33	2.36
20	3.11	12.72	4.65	4.72	3.35

LEVER HOISTS

Capacity (Ton)	Dimensions (in)				
	A	B	C	D	E
3/4	0.61	2.91	0.74	1.42	0.91
1 1/2	0.85	4.04	1.12	1.69	1.10
2	0.94	4.44	1.24	1.85	1.10
3	1.26	4.95	1.37	2.09	1.34
6	1.46	5.98	1.77	2.44	1.81
9	2.13	9.31	3.31	3.54	2.20

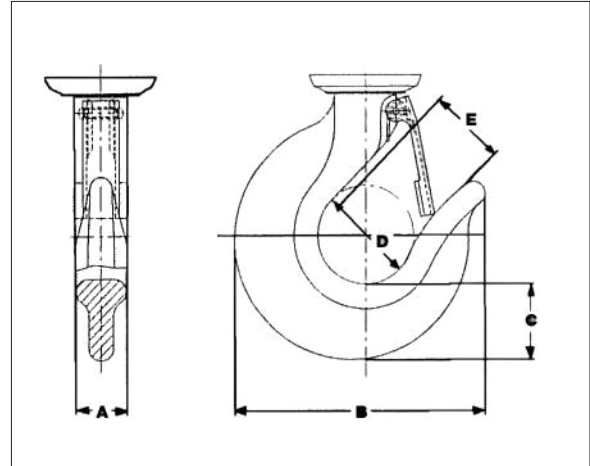

OPTIONS FOR HAND CHAIN HOISTS

Bronze wheels, nickel plated trolley and hoist body, nickel plated hand and load chain, bronze coated hook and load block.

Bronze wheels, bronze load hook and stainless steel load chain.

Stainless steel load chain, bottom block and hook.

Chain container.

