

CableSafe

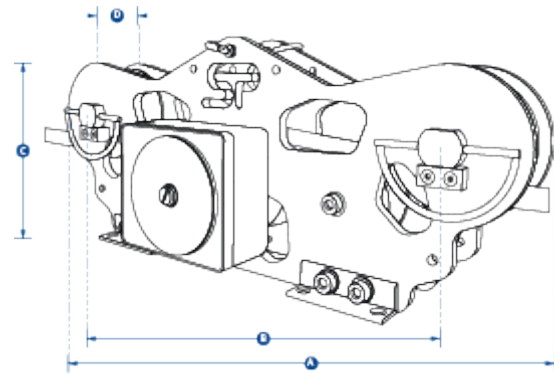

- Simple to use and set up.
- Remote monitoring using smart phone via Bluetooth.
- Rapid tension force measurement - Up to 600m or 1968ft per minute.
- Able to be used in all weather and air quality conditions.
- Providing up to 500 hours battery life.
- Easy to install and replace batteries (4 x AA standard alkaline).
- Fully constructed from aerospace-grade aluminum with anodized finish.
- Five-wheel design, improving accuracy.
- Blue anodized side plates.
- Linchpins are fitted to the top sheave pins, making wire rope installation quick and simple.
- Maintenance free heavy duty bearings.
- Compatible with a wide range of synthetic rope/electrical cable diameters – 4-30mm or 5/32 in – 1 3/16 in.
- IP67 ingress protection or NEMA6 – heavy protection against dust and rain.
- Design validated by FEA.

In addition to the TIMH range, the CableSafe® is the continued evolution of Crosby Straightpoint's running line tensiometers. When used in the field, it will allow the user to monitor tension with exceedingly high levels of accuracy, which ensures rope/cables do not become overstretched or break.

When using a capstan winch to unwind electrical cable from a reel/spool, you will be able to integrate the CableSafe within this set-up to ensure that it is being pulled at a safe tension level. This helps the line maintain its transmissions capability, prevent it becoming a fire hazard risk, and it also stops the need of furthering work in order to remove and replace it. The contractor is gifted with decreased liability, dramatically increasing peace of mind.

Part Numbers SP	CableSafe	CableSafe-WD
Crosby	2789219	2789399
Capacity	10 t	10 t
	22000 lb	22000 lb
Resolution	0.01 t	0.01 t
	20 lb	20 lb
Synthetic Rope / Electrical Cable Ø	4-19 mm	9.5-30 mm
	5/32"- 3/4"	3/8"- 1 3/16"
Weight	4.5 kg	8 kg
	10 lb	17.6 lb
Battery Type	4 x AA Alkaline	
Battery Life	500 hours	
Operating Temp.	-10°C to +50°C / 14°F to 122°F	
Accuracy	±2% of full scale	
Range	Bluetooth 100 meters / 328 feet	
Protection	IP67 / NEMA6	
Maximum Speed	600 m per minute	
	1,968 ft per minute	
Dimension A	422 mm	422 mm
	16.61"	16.61"
Dimension B	328 mm	328 mm
	12.91"	12.91"
Dimension C	152 mm	152 mm
	5.98"	5.98"
Dimension D	36.5 mm	50.5 mm
	1.43"	2"

Using CableSafe on cable pulls reduces liabilities on cable installations, making it ideal for the following applications:

- Measure tension when pulling electrical cables – protect against fractures or elongation
- Measuring tension on synthetic rope when erecting delicate structures using gin poles and capstan winch

Another example of best use is during the installation of cell phone towers or similar delicate structures. The product helps ensure structure-to-ground ropes which are connected to a gin pole and pulley system. Avoid the unknown through accurate monitoring, especially when risks are high.