

## CROSBY® WELD-ON PIVOTING LINK

### WARNING & APPLICATION INSTRUCTIONS



S-265

#### ⚠ WARNING

- Loads may disengage from link if proper welding, assembly, and lifting procedures are not used.
- A falling load may cause serious injury or death.
- Do not use with damaged slings or chain. For sling inspection criteria see ASME B30.9.
- Read and understand these instructions before welding on, or using the pivoting link.

#### Important Safety Information - Read and Follow

- Use weld-on pivoting link only with ferrous metal (steel) workpiece.
- After determining the loads on each weld-on pivoting link, select the proper size using the Working Load Limit (WLL) ratings in Table 1 on next page.
- Always make sure the weld-on pivoting link and mounting surface is free of dirt or contaminants before installation.
- Never use spacers between the weld-on pivot link and mounting surface.
- Always select proper load rated lifting device for use with weld-on pivoting link.
- Attach lifting device ensuring free movement of weld-on pivoting link bail (Figure 1).
- Apply partial load and check proper alignment. There should be no interference between load (workpiece) and weld-on pivoting link (Figure 2).
- Always ensure free movement of bail. The bail should pivot 180 degrees (Figure 4).
- The support structure that the pivot link is attached to must be of suitable size, composition and quality to support the anticipated loads of all operating positions. The required support structure thickness for a given application is dependent on variables such as unsupported length and material strength, and should be determined by a qualified individual.
- Never repair, alter, rework or reshape the pivoting link bail by welding, heating, burning or bending.

## Weld-on Pivoting Link Inspection / Maintenance

- Always inspect weld-on pivoting link before use.
- Regularly inspect weld-on pivoting link parts (Figure 3).
- Never use weld-on pivoting link that shows signs of corrosion, wear or damage.
- Never use weld-on pivoting link if bail is bent or elongated.
- Do not use part showing cracks, nicks or gouges.
- Always make sure there are no spacers used between weld-on pivoting link and the mounting surface.
- Always be sure workpiece surface is in total contact with the weld-on pivoting link base mating surface.
- Always inspect the weld-on pivoting link bail and base for wear.
- A visual periodic inspection of the weld should be performed. Check the weld visually, or use a suitable NDE method if required.

## Operating Safety

- Never exceed the capacity (WLL) of the weld-on pivoting link (Table 1, next page).
- Always apply load within 90° of inline, at any pivot angle (Figure 4 & 5).
- When using lifting slings of two or more legs, make sure the forces in the legs are calculated using the angle from the horizontal sling angle to the leg and select the proper size link.

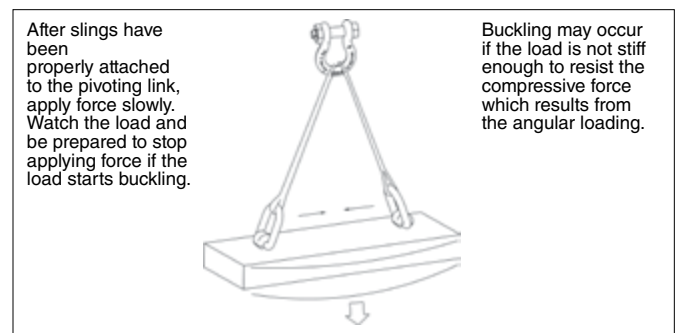
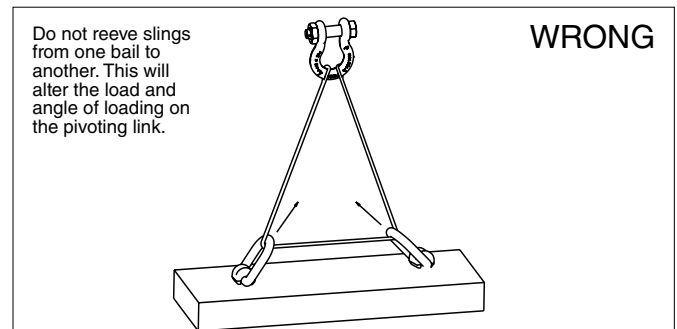

Figure 1

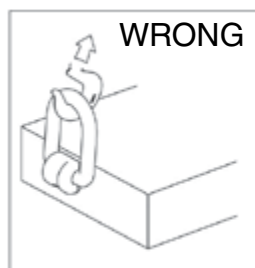

Figure 2



Figure 3

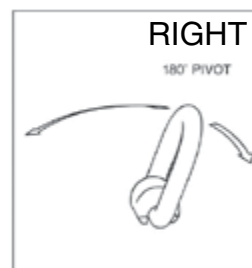

Figure 4

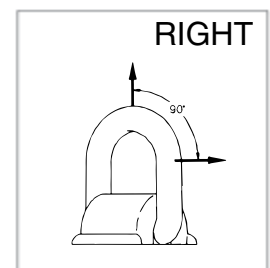

Figure 5