

IPBG

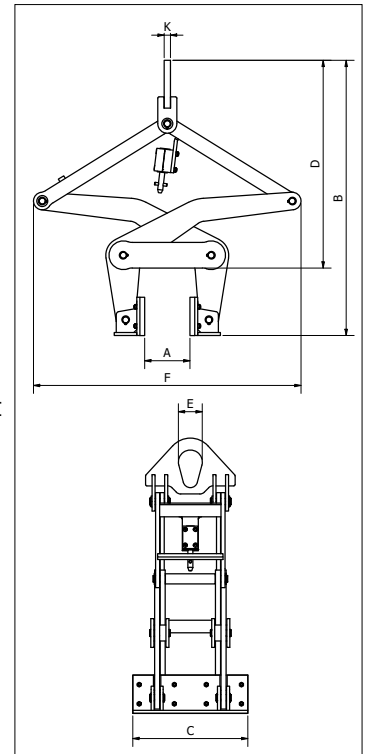

The CrosbyIP Barrier Grab provides a fast and efficient method for handling road barriers.

- Hands-free operation.
- Welded alloy steel construction for strength and smaller size.
- Comes equipped with polyurethane pads. (Replacement kits are available.)
- Individually Proof Tested to 2 times the Working Load Limit with certification.
- Company name (Crosby IP), logo, Working Load Limit and jaw opening permanently stamped on body.
- Each product is individually serialized, with the serial number and Proof Load test date stamped on body. User manual with test certificate is included with each clamp.



Load Rated

## Barrier Grab

Model	WLL (t)*	Stock No.	Weight Each (lb)	Dimensions (in)						
				Jaw A	B	C	D	E	F	K
IPBG	4	2704018	345	6 (min.)	45.3	18.0	34.7	3.74	40.9	1.00
				12 (max.)	33.9	18.0	23.5	3.74	44.4	1.00

\* Design factor based on EN13155 and ASME B30.20.