

IPPE10B(E)



For lifting and transporting non-bendable sheet metal in a horizontal position.

- Available in capacities of 3 through 12 metric tons (higher Working Load Limits are available upon request).
- Wide variety of jaw openings available: 0 to 7.13”.
- Welded alloy steel body for strength and smaller size. Forged alloy components, where required.
- Individually Proof Tested to 2 times the Working Load Limit with certification.
- Company name (Crosby IP), logo, Working Load Limit and jaw opening permanently stamped on body.
- Each product is individually serialized, with the serial number and Proof Load test date stamped on body. User manual with test certificate is included with each clamp.
- Maintenance and repair kits are available.
- IPPE10B: Magnets in foot plate (also applies for D and H Type).
- IPPE10BE: Economic version (also applies for D and H-Type).
- IPPE10BNM: Non-marring (also applies for D and H-Type).

IPPE10BNM



Load Rated

Model IPPE10B / IPPE10BE / IPPE10BNM

Model	Working Load Limit (Per Pair) (t)*	Stock No.	Weight Each (lb)	Dimensions (in)									
				Jaw A	B	C	D	E	F	G	H	J	L
IPPE10B	3	2703862	25.0	0 - 7.13	8.03	12.68	0.79	1.02	2.60	0.79	3.94	1.97	0.59
IPPE10B	6	2703871	35.0	0 - 7.13	8.66	13.39	0.98	1.18	2.91	0.79	5.51	2.36	0.51
IPPE10B	9	2703888	54	0 - 7.13	9.76	14.37	0.98	1.34	3.54	0.79	7.48	2.76	0.51
IPPE10B	12	2703921	72	0 - 7.13	9.92	14.80	1.18	1.57	3.54	0.98	7.87	2.76	0.71
IPPE10BE	3	2703863	25	0 - 7.13	8.03	12.68	0.79	1.02	2.60	0.79	3.94	1.97	0.59
IPPE10BE	6	2703870	36	0 - 7.13	8.66	13.39	0.98	1.18	2.91	0.79	5.51	2.36	0.51
IPPE10BE	9	2703891	55	0 - 7.13	9.76	14.37	0.98	1.34	3.54	0.79	7.48	2.76	0.51
IPPE10BE	12	2703924	72	0 - 7.13	10.31	14.80	1.18	1.57	3.54	0.98	7.87	2.76	0.71
IPPE10BNM	3	2703864	27	0 - 7.13	8.03	12.68	1.18	1.02	2.68	0.79	3.94	1.97	0.59
IPPE10BNM	6	2703872	38	0 - 7.13	8.66	13.39	1.38	1.18	2.99	0.79	5.51	2.36	0.51
IPPE10BNM	9	2703894	61.0	0 - 7.13	9.76	14.37	1.38	1.34	3.62	0.79	7.48	2.76	0.51
IPPE10BNM	12	2703927	77.0	0 - 7.13	10.31	14.80	1.57	1.57	3.62	0.98	7.87	2.76	0.59

12

* Design Factor based on EN 13155 and ASME B30.20. Also available in D-Type (maximum jaw opening of 11.75”) and H-Type (maximum jaw opening of 16.50”).

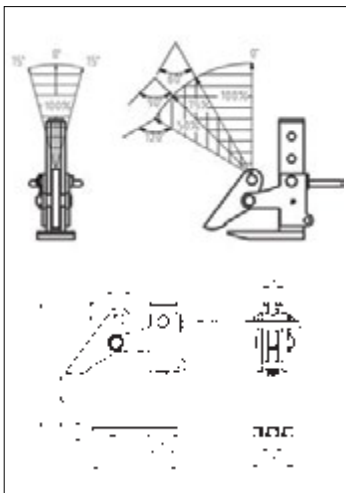

IPPE10(E)

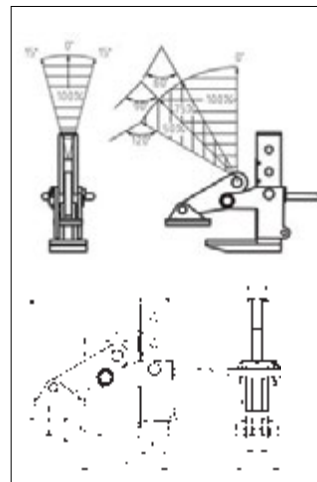

IPPE10NM