

G-416 / S-416

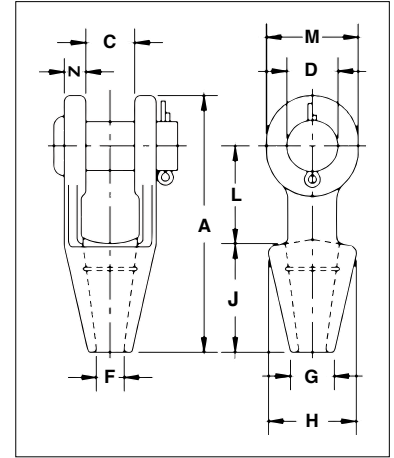

- Forged steel sockets through 1-1/2", cast alloy steel 1-5/8" through 4".
- Spelter socket terminations have an efficiency rating of 100%, based on the catalog strength of wire rope.
- Ratings are based on recommended use with 6 x 7, 6 x 19 or 6 x 37, IPS or XIP (EIP), XXIP (EEIP), RRL, FC or IWRC wire rope.
- Strand constructed with minimal number of wires (e.g. 1 x 7) requires special consideration that socket basket length be five (5) times the strand diameter or fifty (50) times the wire diameter, whichever is the greater.
- All cast steel sockets 1-5/8" and larger are magnetic particle inspected and ultrasonic inspected. Proof testing available on special order.
- Available with bolt nut and cotter: G-416B.
- Open Grooved Sockets meet the performance requirements of Federal Specification RR-S-550F, Type A, except for those provisions required of the contractor.



G-416 / S-416 Open Spelter Sockets

Rope Dia.		Structural Strand Dia. (in)	Ultimate Load (t)	Stock No.		Weight Each (lb)	Dimensions (in)										Tolerance +/-
(in)	(mm)			G-416 Galv.	S-416 S.C.		A	C	D	F	G	H	J	L	M	N	
5/16-3/8	8-10	—	12	1039637	1039646	1.30	4.84	.81	.81	.50	.81	1.69	2.25	1.75	1.50	.44	.06
7/16-1/2	11-13	—	20	1039655	1039664	2.25	5.56	1.00	1.00	.56	.94	1.88	2.50	2.00	1.88	.50	.06
9/16-5/8	14-16	1/2	27	1039673	1039682	3.60	6.75	1.25	1.19	.69	1.13	2.25	3.00	2.50	2.25	.64	.06
3/4	18	9/16-5/8	43	1039691	1039708	5.83	7.94	1.50	1.38	.81	1.25	2.62	3.50	3.00	2.62	.62	.06
7/8	20-22	11/16-3/4	55	1039717	1039726	9.65	9.25	1.75	1.63	.94	1.50	3.25	4.00	3.50	3.13	.80	.06
1	24-26	13/16-7/8	78	1039735	1039744	15.50	10.56	2.00	2.00	1.13	1.75	3.75	4.50	4.00	3.75	.88	.06
1-1/8	28-30	15/16-1	92	1039753	1039762	21.50	11.81	2.25	2.25	1.25	2.00	4.12	5.00	4.62	4.12	1.00	.12
1-1/4 - 1-3/8	32-35	1-1/16 - 1-1/8	136	1039771	1039780	31.00	13.19	2.50	2.50	1.50	2.25	4.75	5.50	5.00	4.75	1.13	.12
1-1/2	38	1-3/16 - 1-1/4	170	1039799	1039806	47.25	15.12	3.00	2.75	1.63	2.75	5.25	6.00	6.00	5.38	1.19	.12
* 1-5/8	* 40-42	1-5/16 - 1-3/8	188	1039815	1039824	55.00	16.25	3.00	3.00	1.75	3.00	5.50	6.50	6.50	5.75	1.31	.12
* 1-3/4 - 1-7/8	* 44-48	1-7/16 - 1-5/8	268	1039833	1039842	82.00	18.25	3.50	3.50	2.00	3.13	6.38	7.50	7.00	6.50	1.56	.12
* 2 - 2-1/8	* 50-54	1-11/16 - 1-3/4	291	1039851	1039860	129.00	21.50	4.00	3.75	2.25	3.75	7.38	8.50	9.00	7.00	1.81	.12
* 2-1/4 - 2-3/8	* 56-60	1-13/16 - 1-7/8	360	1039879	1039888	167.00	23.50	4.50	4.25	2.50	4.00	8.25	9.00	10.00	7.75	2.13	.12
* 2-1/2 - 2-5/8	* 64-67	1-15/16 - 2-1/8	424	1041633	1041642	252.00	25.50	5.00	4.75	2.88	4.50	9.25	9.75	10.75	8.50	2.38	.12
* 2-3/4 - 2-7/8	* 70-73	2-3/16 - 2-7/16	511	1041651	1041660	315.00	27.25	5.25	5.00	3.12	4.88	10.50	11.00	11.00	9.00	2.88	.25
* 3 - 3-1/8	* 75-80	2-1/2 - 2-5/8	563	1041679	1041688	380.00	29.00	5.75	5.25	3.38	5.25	11.12	12.00	11.25	9.50	3.00	.25
* 3-1/4 - 3-3/8	* 82-86	2-3/4 - 2-7/8	722	1041697	1041704	434.00	30.88	6.25	5.50	3.62	5.75	11.88	13.00	11.75	10.00	3.12	.25
* 3-1/2 - 3-5/8	* 88-92	3 - 3-1/8	779	1041713	1041722	563.00	33.25	6.75	6.00	3.88	6.50	12.38	14.00	12.50	10.75	3.25	.25
* 3-3/4 - 4	* 94-102	—	875	1041731	1041740	783.00	36.25	7.50	7.00	4.25	7.25	13.62	15.00	13.50	12.50	3.50	.25

* Cast alloy steel.