



IPCC

The IPCC is suitable for the vertical lifting and transfer of concrete pipe sections and wells. Very easy application and removal of the clamp thanks to the built-in carrying-grips. Normally used in combination with 7mm chain (not supplied). These clamps must be used in pairs or more.

For Lifting and Transferring Concrete Pipe Sections and Wells

- Available in capacity of 1 metric tons.
- Jaw opening available: 1.57" - 5.51".
- Welded alloy steel body for strength and smaller size. Forged alloy, components where required.
- Equipped with handle for easy placement.
- Individually Proof Tested to 2 times the Working Load Limit with certification.
- Company name (CrosbyIP), logo, Working Load Limit and jaw opening permanently stamped on body.
- Each product is individually serialized, with the serial number and Proof Load test date stamped on body. User manual with test certificate is included with each clamp
- Maintenance replacement parts are available.
- Manufactured by an ISO 9001 facility.
- All sizes are **RFID EQUIPPED**.

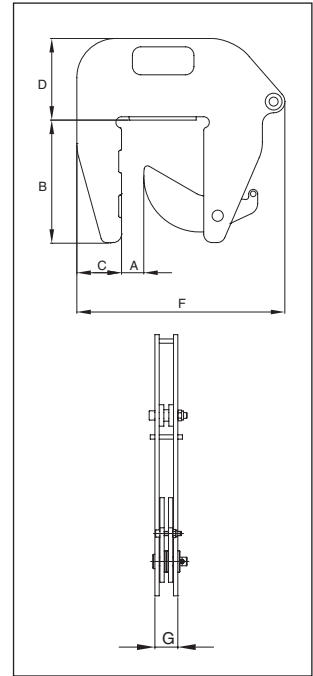

Load Rated®

Model IPCC

Model	IPCC Stock No.	Working Load Limit Per Pair (t.)*	Weight Each (lb)	Dimensions (in)									
				Jaw A	B	C	D	E	F	G	H	J	K
IPCC	2700037	1.0	40.6	1.56 - 5.50	8.86	3.15	5.75	-	14.65	1.46	-	-	-

* Design Factor based on EN 13155 and ASME B30.20.

