

Crosby[®]

FAST AND EFFICIENT LIFTING FOR PLATES & ROUND STEEL

Crosby MAGNEX™ Lifting Magnet

NEW

Crosby MAGNEX™ Lifting Magnets provide a fast and efficient method for lifting plates and round steel or any similarly shaped fabrications.

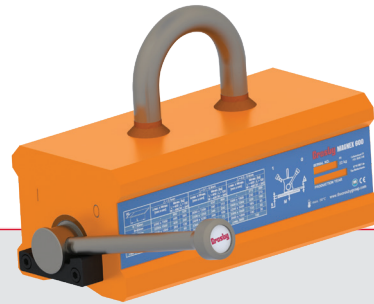

Features & Benefits

- Solid steel construction with recessed area, reducing risk of damage to tags for identification and technical user information.
- Fully welded construction, minimizing maintenance costs.
- Innovative and patented easy switch stop block, equipped with ballbearing and ergonomic handle for increased safety and ease of use.
- Individually proof tested to 3 times the working load limit with certification.
- Each product is individually serialized, with the serial number and proof load test date stamped on body.
- User manual with test certificate included with each magnet
- 5-year warranty on magnetic system.
- CE certified including test certificate in accordance with EN 13155.
- Maintenance replacement kits are available.
- Can be used on both flat and round steel surfaces.



Rig Safe. Rig Smart. Rig Crosby.

thecrosbygroup.com

Crosby MAGNEX™ Lifting Magnet

Fast and efficient lifting for plates and round steel

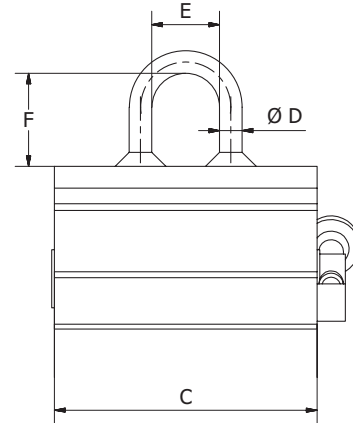
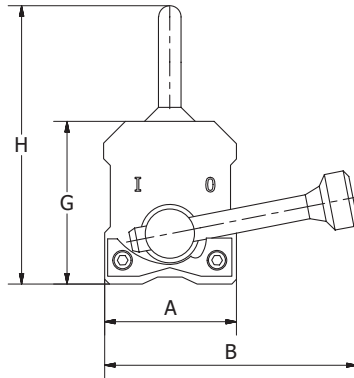
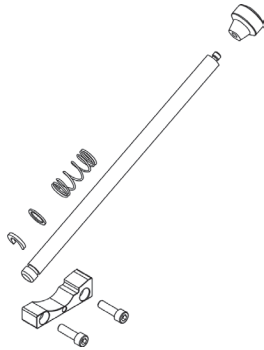

METRIC

Model	Stock No.	WLL (kg)*	Weight each (kg)	Dimensions (mm)							
				A	B	C	D	E	F	G	H
MAGNEX150	2708023	150	3.1	60	115	102	10	30	40	69	119
MAGNEX300	2708024	300	10.9	100	210	152	14	50	65	99	178
MAGNEX600	2708025	600	21.7	120	245	246	20	64	65	99	184
MAGNEX1000	2708026	1000	40.9	146	329	305.5	20	64	92	124.5	236.5
MAGNEX1500	2708027	1500	71.7	165	392	374	20	64	92	161	273
MAGNEX2000	2708028	2000	91.4	165	475	478	20	64	92	161	273

Model	Flat material			Round material		
	WLL (kg)*	min. thickness for max. WLL (mm)*	min. Load thickness (mm)	WLL (kg)*	min. Ø (mm)	max. Ø (mm)
MAGNEX150	150	25	2	75	50	100
MAGNEX300	300	30	4	150	60	200
MAGNEX600	600	40	6	300	65	270
MAGNEX1000	1000	60	10	500	100	300
MAGNEX1500	1500	80	15	750	150	350
MAGNEX2000	2000	80	15	1000	150	350

*WLL based on low carbon, mild steel & working temperature 20°C

IMPERIAL

Model	Stock No.	WLL (lbs)*	Weight each (lbs)	Dimensions (inch)							
				A	B	C	D	E	F	G	H
MAGNEX150	2708023	331	6.8	2.4	4.5	4.0	0.4	1.2	1.6	2.7	4.7
MAGNEX300	2708024	661	24	3.9	8.3	6.0	0.6	2.0	2.6	3.9	7.0
MAGNEX600	2708025	1323	47.8	4.7	9.6	9.7	0.8	2.5	2.6	3.9	7.2
MAGNEX1000	2708026	2205	90.2	5.7	13.0	12.0	0.8	2.5	3.6	4.9	9.3
MAGNEX1500	2708027	3307	158.1	6.5	15.4	14.7	0.8	2.5	3.6	6.3	10.7
MAGNEX2000	2708028	4409	201.5	6.5	18.7	18.8	0.8	2.5	3.6	6.3	10.7

Model	Flat material			Round material		
	WLL (lbs)*	min. thickness for max. WLL (in)*	min. Load thickness (in)	WLL (lbs)*	min. Ø (in)	max. Ø (in)
MAGNEX150	331	0.98	0.08	166	2.0	3.9
MAGNEX300	661	1.18	0.16	331	2.4	7.9
MAGNEX600	1323	1.57	0.24	662	2.6	10.6
MAGNEX1000	2205	2.36	0.39	1103	3.9	11.8
MAGNEX1500	3307	3.15	0.59	1654	5.9	13.8
MAGNEX2000	4409	3.15	0.59	2205	5.9	13.8

*WLL based on low carbon, mild steel and a working temperature 68°F

