



# Crosby®

## WIRE ROPE END TERMINATIONS

### User's Manual

Featuring Application and  
Installation Procedures for:

National Swage Fittings  
Crosby Spelter Sockets  
Crosby Mooring Sockets  
Crosby Wedge Sockets  
Crosby Wire Rope Clips  
WIRELOCK® Socketing Resin

# Table of Contents

## Wire Rope End Termination User's Manual

General Information.....	1
General Cautions and Warnings.....	2
Definitions.....	3 - 5
Swage Terminations ..... (Swaging Machines, Sleeves, Sockets, Buttons, Hooks, Die Selection, Swaging Instructions)	7 - 56
Crosby® Spelter Terminations ..... (Spelter Sockets, Button Sockets, Mooring Sockets)	57 - 67
WIRELOCK® ..... (Preparation, Pouring, Testing, Approvals, MSDS)	69 - 95
Wedge Socket Terminations ..... (Preparation, Pouring, Testing, Approvals, MSDS)	97 - 106
Wire Rope Clips..... (U-Bolt, Fist Grip®)	107 - 116



Scan this QR Code with your smart device to visit our website.

**Corporate Office**  
2801 Dawson Road  
Tulsa, OK 74110  
P: (918) 834-4611  
F: (918) 832-0940  
crosbygroup@thecrosbygroup.com

**Canada**  
3660 Odyssey Dr, Unit 4  
Mississauga, Ontario  
Canada L5M 0Y9  
P: (877) 462-7672  
F: (877) 260-5106  
sales@crosby.ca

**Europe**  
Industriepark Zone b N°26  
2220 Heist-op-den-Berg  
Belgium  
P: (+32) (0)15 75 71 25  
F: (+32) (0)15 75 37 64  
sales@crosbyeurope.com

[www.thecrosbygroup.com](http://www.thecrosbygroup.com)

*The Market Leader Yesterday, Today and Tomorrow*

## General Information

The purpose of this manual is to provide a resource for preparing wire rope terminations when using Crosby products. The publication contains the recommendations of The Crosby Group LLC, OSHA, ASME and the Wire Technical Board. All recommendations in this manual assume the use of Crosby products. Properly following the procedures will produce the most reliable and efficient terminations available. Crosby provides valuable knowledge about swaging, socketing and other termination processes. This knowledge is the result of many years of extensive testing and “on the job” experience.

There are many types of wire rope end terminations that can be produced. Your choice will be dependent upon the application and the task in which the termination is going to be used. The Working Load Limit (WLL) rating of the termination/wire rope combination is not entirely a function of the fitting being used. Therefore, the anticipated efficiency is shown as a function of the wire rope strength. Refer to either the Wire Rope Technical Board’s “Wire Rope Sling User’s Manual” for the wire rope’s rated capacity, or the “Wire Rope User’s Manual” for the minimum breaking force of the wire rope, whichever applies to your application.

It is important that the proper components be used to make a termination. For a specific style of wire rope termination you must choose the correct type and size of fitting, the correct swaging dies if a swage product is required, the correct WIRELOCK® Kit if splintered product is required, and proper construction of wire rope as shown in the Crosby General Catalog.

These Crosby instructional materials provide basic application information for the Crosby products and their use with selected other lifting devices. Refer to all manufacturer’s warnings, the current Crosby Seminar workbook, the current Crosby General Catalog and current OSHA and ASME standards as they apply.

References to ASME, OSHA and WRTB are for the revisions in effect at time this booklet was printed.

The Crosby Group LLC reserves the right to change product design, materials and specifications without incurring obligations.

# General Cautions and Warnings

All products manufactured by The Crosby Group LLC are sold with the express understanding that the purchaser is thoroughly familiar with the safe and proper use and application of the product.

Responsibility for the use and application of the products rests with the user. The Crosby Group disseminates product warnings and end user application information through various channels. In addition, Crosby provides formal product training seminars and our engineering personnel are readily available to answer your technical questions. For more information read the Crosby General Catalog, refer to Crosby's web site @ [www.thecrosbygroup.com](http://www.thecrosbygroup.com), or contact your Crosby Distributor or Crosby direct at 918-834-4611.

Failure of the product can occur due to misapplication, abuse or improper maintenance. Product failure could allow the load to become out of control, resulting in possible property damage, personal injury or death.

There are numerous government and industry standards that cover products made by Crosby. This manual makes no attempt to reference all of them. We do reference the standards that are most frequently asked about.

Ratings shown in Crosby Group literature are applicable only to new or "in as new" condition products.

Load Limit ratings indicate the greatest force or load a product can carry under usual environmental conditions. Shock loading and extraordinary conditions must be taken into account when selecting products for use in a system.

In general, the products displayed in Crosby Group literature are used as parts of a system being employed to accomplish a task. Therefore, we can only recommend within the Working Load Limits, or other stated limitations, the use of products for this purpose.

The Working Load Limit, or Design Factor, or Efficiency Rating of each Crosby product may be affected by wear, misuse, overloading, corrosion, deformation, intentional alteration and other use conditions. Regular inspection must be conducted to determine whether use can be continued at the catalog assigned WLL, a reduced WLL, or whether the product must be withdrawn from service.

Crosby Group products generally are intended for tension or pull. Side loading must be avoided, as it exerts additional force or loading which the product is not designed to accommodate.

Welding Crosby load support parts or products can be hazardous. Knowledge of materials, heat treatment and welding procedures are necessary for proper welding. Crosby Group should be consulted for information.

The assigned Ultimate Load Rating of Crosby Group products for the reeving of wire, manila or synthetic rope is based upon design; the catalog ultimate strength for the rope parts, when totaled, may exceed the assigned Ultimate Load Rating.

The Working Load Limit of a sling must not exceed the lowest Working Load Limit of the components in the system.

The recommended Proof Load on all items in this manual is 2 times the Working Load Limit unless otherwise shown.

Products that Crosby intends for swaging are identified in this manual. For proper swaging machine training, operations and die selection, refer to specific product section in this manual. To develop other product for swaging requires knowledge of materials, heat treatment, product design, die design and performance of the final product.

Use only new genuine Crosby parts as replacements when servicing or repairing Crosby products.

Crosby products are to be considered as sparking, unless otherwise noted.

Product Label Replacement - In accordance with ANSI535.4-1991, "Product Safety Labels" should be periodically inspected and cleaned. "Product Safety Labels" should be replaced when they are no longer legible. Current Crosby warning and application labels, for applicable products, are available from The Crosby Group LLC.

Two decimal and fractional dimensions shown in catalog are intended as nominal dimensions only. If three decimal dimensions are shown, contact Crosby for tolerance information.

Specific warning and application instructions are included in this manual. The instructions can be found at the end of each product section. The symbol shown to the right can be found on the page for products that have application instructions included in this manual. The page numbers that the specific product information can be found are shown in the box for easy reference.

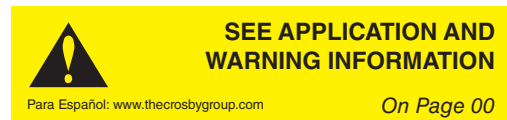

## Low Temperature Service

Crosby forged and cast steel products can be used in general service conditions down to temperatures of -40° F (-40° C). McKissick blocks can be used in general service conditions down to temperatures of -4° F (-20° C). At temperatures from 0° F to -40° F (-18° C to -40° C), good rigging practice requires special attention in the following areas.

1. Lifting should be performed at a steady rate. Shock loading should be avoided.
2. Equipment containing bearings should have increased inspection and maintenance schedule, and may require special lubrication.
3. All lifting equipment should be given a thorough visual inspection before each lift.
4. Remove nicks, gouges, or cracks by grinding (5% maximum material removal).
5. Do not use fittings that have been welded or modified after leaving the factory.
6. If determined to be necessary by the user, lifting equipment should undergo periodic inspection by dye penetrant or magnetic particle surface inspection.

For operation at temperatures below -40° F (-40° C), consider "Cold Tuff" products or contact Crosby Engineering.

## Elevated Temperature Service

Crosby forged and cast steel products can be used in general service conditions up to temperatures of 400° F (204° C). The following should be considered when operating up to temperatures of 400° F (204° C).

1. Products that contain non-ferrous materials, and lubricants, plastics, etc. may be adversely affected by high temperatures, and typically should not exceed 200° F (93° C).
2. Galvanized, plated or painted fittings may suffer some or total degradation of the surface finish.
3. Extended exposure to elevated temperatures can cause severe surface scaling and significant permanent reduction of properties.
4. Repeated heating and cooling to room temperatures can result in temper embrittlement.

For other operating temperatures or products, contact Crosby Engineering.

# Definitions

**ANSI** – American National Standards Institute

**ASME** – American Society of Mechanical Engineers

**ASTM** – American Society for Testing and Materials

**Boom Pendant** – A non-operating rope or strand with end terminations used to support the boom.

**Closed Socket** – A wire rope end termination consisting of basket and bail made integral (Crosby G-417/S-417 and S-502).

**Core** – The axial member of a wire rope around which the strands are laid.

**Commercial Surface Quality** – The surface condition of the products shown in this catalog. The surface condition associated with the normal methods of production of raw materials and machined surfaces. More refined surface qualities are considered as special.

**Design Factor** – An industry term denoting a product's theoretical reserve capability; usually computed by dividing the catalog Ultimate Load by the Working Load Limit and generally expressed as a ratio, e.g., 5 to 1.

**Duplex Non-Tapered Sleeves** – Oblong cylindrical sleeves used for fabricating wire rope turnback sling eyes. Also used on grommet slings (Crosby S-506).

**Dross** – The impurities that form on top of the molten metal.

**Extra Improve Plow Steel (EIPS)** – A grade of wire rope.

**End Termination** – The treatment at the end or ends of a length of wire rope, usually made by forming an eye or attaching a fitting and designed to be the permanent end termination on the wire rope that connects it to the load.

**Eye or Eye Splice** – A loop, with or without a thimble, formed at the end of a wire rope.

**Fatigue Rated** – Tested to a minimum standard of 20,000 cycles at 1.5 times the Working Load Limit. Will meet the requirements of the Euronorm standards for fatigue.

**Fiber Core (FC)** – Cord or rope of natural or synthetic fiber used as the axial member of a strand.

**Fist Grip Wire Rope Clips** – Fitting for clamping parts of wire rope to each other to form an eye or splice. (Crosby G-429 Fist Grip® Clips)

**Flashing** – Occurs when sleeve or socket material flows out into the area between the die faces. See picture.



**Flemish Eye** – A mechanical splice termination formed by unlaying the end of the rope body into two parts, and forming an eye by looping the two parts in opposite directions and laying the rope back together. A swaged metal sleeve secures the ends to the body of the sling.

**Full Die** – A process where the complete fitting is inserted into the die and swaged following specific swaging procedures for the product.

**Full Shank** – A process where the full shank length of the fitting is inserted into the die and swaged following specified swaging procedures for the product.

**Improved Plow Steel (IPS)** – A grade of wire rope. A term for a steel wire cold drawn with a tensile strength of 225,000 to 295,000 P.S.I.

**Independent Wire Rope Core (IWRC)** – A wire rope used as an axial member of a larger wire rope.

**Lang Lay** – The type of rope in which the lay of the wires in the strand is in the same direction as the lay of the strand in the rope. The crowns of the wires appear to be at an angle to the axis of the rope.

# Definitions

**Lay** – a) the manner in which the wires in a strand or the strands in a rope are helically laid.

b) the distance measured parallel to the axis of the rope (or Strand) in which a strand (or wire) makes one complete helical convolution about the core (or center) – In this connection, Lay is also referred to as Lay Length or Pitch.

**Lay of Rope** –



**Marlin Spike** – A tapered steel pin used in wire rope splicing.

**Open Socket** – A wire rope fitting that consists of a basket and two ears with a pin (Crosby G-416/S-416, S-423T, S-501, SB-427).

**Plow Steel (PS)** – Wire rope steel that contains 0.5 to 0.95 percent carbon.

**P.S.I.** – Pounds per square inch (Pressure).

**Poured Socket** – A socket attached by means of zinc or resins.

**Progressive Swaging** – A process where only a portion (Crosby information is set up on thirds for its swaging machine capacity charts on page 66 in the 2014 Catalog) of the length of the fitting is inserted into the die and swaged following specific swaging procedures for that product.

**Proof Load** – The average force applied in the performance of a proof test; the average force to which a product may be subjected before deformation occurs.

**Proof Test** – A test applied to a product solely to determine injurious material or manufacturing defects.

**Pull Amount or Tail** – The standard amount of wire used in a mechanical splice to complete the splice and give ample gripping area for the sleeve to secure the termination.

**QUIC-CHECK®** – Swage Sockets incorporate a reduced machined area of the shank end of the swage socket. Before swaging, provides for an obvious visual difference in the shank diameter. After swaging, uniform shank diameter is created allowing for a QUIC CHECK® and permanent visual inspection opportunity.

Designed to quickly determine whether the socket has been through the swaging operation. It does not eliminate the need to perform standard production inspections which include gauging for the proper after swage dimensions or proof loading.

**QUIC-PASS®** – Crosby swaging process that is completed in just two passes.

**Regular Lay** – The type of rope where the lay of the wires in the strand is in the opposite direction to the lay of the strand in the rope. The crowns of the wires appear to be parallel to the axis of the rope.

**RLL** – Right Lang Lay.

**Right Regular Lay Rope (RRL)** – Strands of wire rope laid to the right with the wire in each strand laid to the left. Right Regular Lay is recommended for use with Crosby National Swage Products.

**Seale** – The name for a type of strand pattern that has two adjacent layers laid in one operation with any number of uniform sized wires in the outer layer, and with the same number of uniform but smaller sized wires in the inner layer.

**Shock Load** – A force that results from the rapid application of a force (such as impacting or jerking) or rapid movement of a static load – A shock load significantly adds to the static load.

**Socket** – Generic name for a type of rope fitting used to terminate wire rope, such as wedge socket, spelter socket, or swage socket (Crosby G-416/S-416, G-417/ S-417, G-517, SB-427, S-421T/S-422T/ S-423T).

# Definitions

**Spring Back** – A condition that occurs when swaging a fitting to form a termination; whereby the material moves out a small amount when the dies are open.

**Swaging** – The process of mechanically forming a fitting onto the eye or end of wire rope.

**Static Load** – The load resulting from a constant applied force or load.

**Swaged Fitting** – Fitting into which wire rope can be inserted and then permanently attached by swaging the shank that encloses the rope (Crosby S-319SWG, S-409, S-501, S-502, S-505 and S-506).

**Thimble** – Grooved metal fitting to protect the eye, or fastening loop of a wire rope (Crosby G-408, G-411, G-414, G-414SL, and S-412).

**U-Bolt Wire Rope Clips** – Fittings for clamping parts of wire rope to each other to form an eye or splice (Crosby G-450 Red-U-Bolt® Clips).

**Ultimate Load** – The average load or force at which the product fails or no longer supports the load.

**Wedge Socket** – A wire rope fitting wherein the rope end is secured by a wedge (Crosby S-421T, S-423T and McKissick US-422T Wedge Style Sockets).

**Wire Rope Clips** – Fitting for clamping parts of wire rope to each other (Crosby G-450 Red-U-Bolt Clips and G-429 Fist Grip® Clips).

**WIRELOCK®** – A resin based mixture used for forming a 100% efficient termination for wire rope in sockets.

**Working Load** – The maximum mass or force which the product is authorized to support in a particular service.

**Working Load Limit (WLL)** – The maximum mass or force which the product is authorized to support in general service when the pull is applied in-line, unless noted otherwise, with respect to the centerline of the product. This term is used interchangeably with the following terms:

1. WLL
2. Rated Load Value
3. Resultant Working Load







# Introduction to Crosby End Terminations

Wire rope is a very useful tool. However, for the wire rope to be utilized, some approved type of termination must be attached. The Crosby Group LLC manufactures a variety of fittings designed specifically to terminate wire rope (see table below). Guidelines and procedures for the application of terminations shown are covered in this manual.

The type of end termination selected is determined by the application and strength required of the final assembly. Each wire rope termination attaches with a special method which may affect the strength of the wire rope.

The terminations and stated efficiency shown in this document are based on the specific wire rope constructions defined for each respective product. It is understood that other constructions of wire rope and strand are available in a variety of different constructions.

**Before using any National Swage fitting with any other type lay, construction or grade of wire rope stated in the note for that fitting, it is recommended that the termination be destructive tested and documented to prove the adequacy of the assembly to be manufactured.**

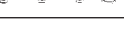
Termination Type	Termination Efficiency
 Swage Sockets	100%
 Spelter Sockets	100%
 Wedge Sockets	80%
 Swage Buttons	98%
 Flemish Eyes	90% or Better
 Turnback Eyes	90% or Better
 Wire Rope Clips	80% or Better

## Termination Efficiency

The strength of the wire rope is measured by the concept of efficiency. The efficiency ratings for wire rope end terminations are based upon the minimum breaking force of the wire rope. The table above depicts some of the more common termination types and their efficiencies. Notice the efficiencies range from 80 percent for wedge sockets and wire rope clips to 100 percent for swaged and speltered sockets.

What does efficiency mean in the field? An 80 percent efficient termination will result in only 80 percent of the wire rope's minimum breaking force being available to be utilized. To determine the actual working load limit that can be assigned to a particular termination, the required design factor must then be applied to this reduced breaking strength.

## Example #1:

Wire rope clips need to be applied to 5/8" IWRC EIPS wire rope construction. A Crosby 5/8" Wire Rope Clip is considered an 80% efficient termination. The wire rope has a nominal strength of 20.6 tons, and the design factor is 5 to 1. To calculate the allowed WLL for the assembly you would do the following calculations.

$$\text{Ultimate Strength} = \frac{\text{Termination Efficiency}}{\text{Rope's Minimum Breaking Force}} \times$$

$$\text{Working Load Limit (WLL)} = \frac{\text{Ultimate Strength}}{\text{Design Factor}}$$

Or

$$\text{Ultimate Strength} = .80 \times 20.6 = 16.5 \text{ tons}$$

$$\text{WLL} = 16.5 \div 5 = 3.3 \text{ tons}$$

In summary, the WLL of the assembly is determined by the efficiency of the termination, the nominal strength of the rope and the design factor.

## Example #2:

The WLL needs to be determined for a Flemish Eye mechanical spliced wire rope sling using 5/8" IWRC EIPS wire rope construction. A properly made Flemish Eye sling has an approximate efficiency of 96%. The wire rope has a nominal strength of 20.6 tons, and the design factor is 5 to 1. To calculate the allowed WLL for the assembly you would do the following calculations.

$$\text{Ultimate Strength} = .96 \times 20.6 = 19.8 \text{ tons}$$

$$\text{WLL} = 19.8 \div 5 = 3.9 \text{ tons}$$

Note: The efficiencies above are valid only if the terminations are properly fabricated. All ratings given in tons refer to short tons of 2,000 lbs. Ratings given in metric tons equal 2,204 lbs. and are mentioned as "tonnes" (t) or "metric tons".

# Swage Terminations

**S-501  
Open Swage  
Socket**



**S-502  
Closed Swage  
Socket**



**S-319SWG  
Shank Hook**



**S-505  
Standard  
Steel Sleeves**



**S-506  
Duplex Sleeve**



**S-409  
Swage Button**



## Table of Contents

Introduction to Swaging .....	8	National Closed Swage Sockets.....	38
Swaging Information .....	9	Swage Socket Terminations – 1/4” – 1” .....	39
National Hydraulic Swaging Machines .....	10	Swage Socket Terminations – 1-1/8” & Larger .....	40
Swaging Machine Warning .....	11-18	Swage Socket Terminations – Progressive Swaging ....	41
Die Information .....	19-20	Cold Tuff® Swage Fittings – Buttons .....	42
Cold Tuff® Swage Fittings – Intro .....	21	National Swage Buttons.....	43
Cold Tuff® Swage Fittings – S-505 .....	22	Button Terminations – 1/8” – 7/8” .....	44
National Steel Swaging Sleeves .....	23-24	Button Terminations – 1” & Larger .....	45
Metric Die Chart .....	25	Cold Tuff® Swage Fittings – Duplex Sleeves .....	46
Flemish Type Wire Rope Sling Eyes – Introduction .....	26	National Swage Duplex Sleeves .....	47
Flemish Type Wire Rope Sling Eyes – Marking .....	27	Turnback Terminations – 5/16” – 5/8” .....	48
Flemish Type Wire Rope Sling Eyes .....	28	Turnback Terminations – 3/4” – 1-1/4” .....	49
Flemish Type Wire Rope Sling Eyes – 1/4” - 1” .....	29	Swage Fittings – Hooks .....	50
Flemish Type Wire Rope Sling Eyes – 12mm, 20mm & 24mm ....	30	Shank Hooks for Swaging .....	51
Flemish Type Wire Rope Sling Eyes – 1-1/8” - 1-3/4” .....	31-32	Shank Hooks Warning .....	52-53
Flemish Type Wire Rope Sling Eyes – 2” & Larger .....	33-34	Swage Hook Terminations -- 3/16” - 1” .....	54
QUIC-PASS® Swaging Procedures .....	35	Swage Hook Terminations -- 1-1/8” & Larger .....	55
Swage Fittings – Sockets.....	36	Swage Terminal Assemblies – Fatigue Life.....	56
National Open Swage Sockets .....	37		

# Introduction to Swaging

There are many styles of terminations that can be made in the end of wire rope using swage fittings. The choice of the style is dependent upon the application and the task. The Working Load Limit rating of the termination/wire rope combination is not entirely a function of the fitting being used. Therefore, the listing of the working load ratings is not within the scope of this literature. (Refer to the Wire Rope Technical Board's "Wire Rope Sling Users Manual" for these values).

It is important that the proper components be used to make a termination. For a specific style wire rope termination, you must choose the correct size and type of fitting and its corresponding swaging die. The information displayed in this manual is based upon using only a one (1) part, 6 X 19 or 6 X 37; FC, IPS or IWRC EIPS, Right Regular Lay Wire Rope. National Swage fittings are designed to be used with inch and metric size wire ropes as designated in this manual and the Crosby General Catalog.

**Before using any National Swage fitting with any other type lay, construction or grade of wire rope stated in the note for that fitting, it is recommended that the termination be destructive tested and documented to prove the adequacy of the assembly to be manufactured.**

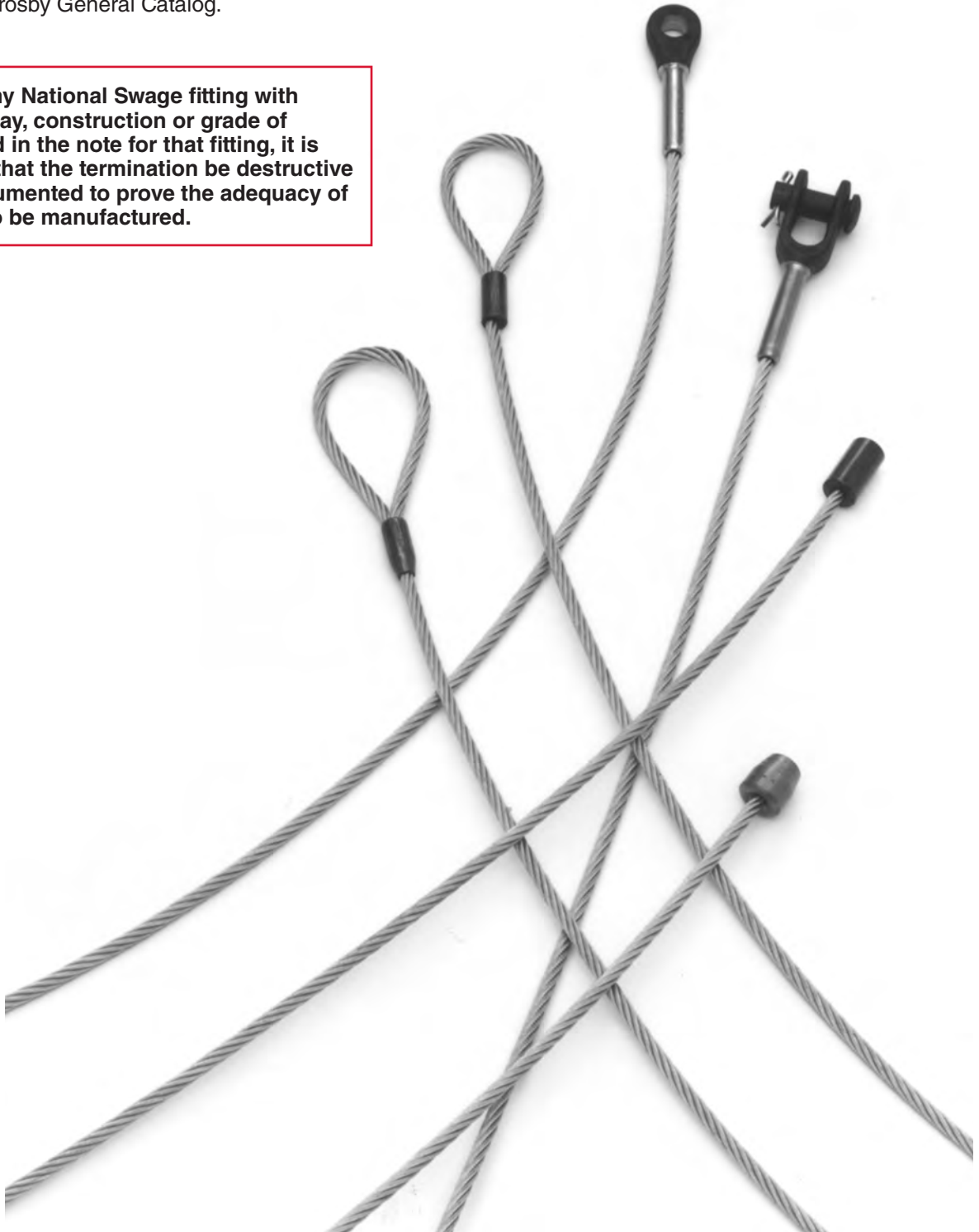

# Swaging Information

The purpose of the swaging process is to produce an efficient termination in the end of wire rope that is permanent. Done properly, the swaging process will produce one of the most reliable and efficient terminations available.

Swaging is a cold forming fabrication method used to permanently attach a specially heat treated forged steel fitting to wire rope in order to form slings, boom pendants or other useful devices for lifting.

The hydraulic swaging equipment, required to provide the slow speed and high pressure necessary for ideal swaging control, causes considerable movement of the steel fitting. The extreme pressure forces the fitting's steel to flow into the crevices between the wires and strands of the wire rope, and at the same time forces the flow along the length of the wire rope.

There are many types of swaged fittings, including:

- Sleeves
- Sockets
- Shank hooks
- Threaded studs

## Efficiency

Efficiency ratings for wire rope end terminations are based upon the minimum breaking force of wire rope.

Termination efficiencies for swaged fittings typically range from 90 to 100 percent.

The efficiency of the termination depends on:

1. The type of fitting
2. Utilizing proper swaging techniques
3. Type and construction of wire rope

These will be covered in greater detail in this section of the manual.

This publication contains the recommendations of The Crosby Group LLC for the use of its products to **produce such terminations.**

National Swage, a member of The Crosby Group LLC, provides the highest quality fittings and equipment available for fabricating swaged wire rope terminations. In addition, National Swage also provides valuable knowledge about the swaging process that is a result of the combination of many years of extensive testing and "on-the-job" training.

## After Swage Dimensions

One of the important considerations in producing a quality termination is the overall diameter of the fitting after the swaging process is complete. Since all dies wear, and the swaged fitting used in terminations have spring back, the results of swaging should be checked after each swaging for proper after swage dimensions to ensure proper sling performance and to determine the wear condition of the die (Per the Warning on page 71 of the 2014 General Catalog, Third statement). In addition to worn dies, not achieving the proper after swage dimension can also be due to the die not being fully closed during swaging. Dies showing excessive wear should be replaced.

The effective swaging that dies can accomplish stops when the die lands touch each other. Any continued swaging adds needless wear and strain on the dies and swaging machine. By placing a light oil on the die faces and in the cavity, the dies will be lubricated as well as protected. The oozing of the oil from the faces of the dies as they touch will indicate when the dies have closed. At this point, stop the swaging cycle. Again, additional swaging adds needless wear and strain to the dies and swaging machine.

For the proper after swage dimensions, see the section in this publication or the General Catalog for the specific product you are swaging.

## Key Facts About Swaging:

1. There are a many styles of terminations that can be made in the end of wire rope using swage fittings. The choice of the style is dependent upon the application and the task.
2. The Working Load Limit rating of the termination/wire rope combination is not entirely a function of the fitting being used. Therefore, the listing of the working load ratings is not within the scope of this literature. (Refer to the Wire Rope Technical Board's "Wire Rope Sling User's Manual" for these values).
3. It is important that the proper components be used to make a termination. For a specific style wire rope termination, you must choose the correct size and type of fitting and its corresponding swaging die.
4. The information displayed in this manual is based upon using only a one (1) part, 6 X 19 or 6 X 37; FC, IPS or IWRC EIPS, Right Regular Lay Wire Rope.
5. National Swage fittings are designed to be used with inch and metric size wire ropes as designated in this manual and the Crosby General Catalog.
6. Before using any National Swage fitting with any other type lay, construction or grade of wire rope stated in the note for this fitting, it is recommended that the termination be destructive tested and documented to prove the adequacy of the assembly to be manufactured.

# Notes

---

# NATIONAL SWAGING MACHINE AND DIE WARNING, USE, MAINTENANCE AND APPLICATION INFORMATION

## National Four Post Swaging Machine



### Operation Safety

- NEVER use dies that are cracked, worn or abraded (galled).
- NEVER use dies that have an oversized cavity.
- ALWAYS use a matched set of dies.
- When swaging steel fittings, DO NOT SHIM DIES. Dies for steel fittings must be free to float and align one to the other.
- When swaging aluminum fittings, THE STEEL DIES MUST BE SHIMMED. Shim the side of the die to ensure the proper cavity alignment for flash removal.
- NEVER shim between the dies.
- When Swaging Crosby National fittings, use only the proper capacity swaging machine for the size of fitting used (See Swaging Capacity Chart). If the swaging machine capacity exceeds the die block Working Load Limit rating, adjust the swaging machine tonnage to the Working Load Limit shown on the die block being used. See Table 1 for die block Working Load Limit.
- Always use the correct size and type of die for the size wire rope fitting used.
- Always lubricate die faces and cavities with light weight oil.
- Progressive swaging of fittings must be done in accordance with procedure shown in “Wire Rope End Terminations User’s Manual”. Only open channel dies are to be used.
- Stop swaging when the cavity side of both dies touch.
- Make sure part is swaged to the recommended after swage dimensions (See Crosby General Catalog or “Wire Rope End Terminations User’s Manual”, Die Guide, or Die Chart).
- If a swage fitting other than a Crosby National is used, determine adequacy of the termination by a destructive pull test.
- All swage sockets must be swaged with socket head adjacent to the socket relief (largest radius) on the die.
- For special applications or conditions, contact Crosby National.

### ⚠ WARNING

- Misuse of swaging machine can result in serious injury or death.
- READ, UNDERSTAND, AND FOLLOW all the information in this warning document and the instructions shown in “Wire Rope End Terminations User’s Manual” before operating the swaging machine.
- Swaging machine operators must be trained in accordance with the information supplied by The Crosby Group LLC. THE SWAGING MACHINE OWNER IS RESPONSIBLE FOR THE TRAINING AND THE SAFE OPERATION OF THE SWAGING MACHINE.
- Do not swage oversize parts.
- Only swage parts of the proper design, material and hardness.
- If misused, dies and/or die holders may break. PROTECT YOURSELF AND OTHERS: Always stay away from the sides of the swaging machine during swaging operations and alert others in your work area.
- Do not shim between dies.
- Do not shim die or die holder unless swaging aluminum sleeves
- Do not use die holders that are damaged or have loose side rails or side plates.
- Keep head, hands, and body away from moving swaging machine and die parts.
- Consult die manufacturer for correct use of their product.
- Adjust swaging machine tonnage to the Working Load Limit (WLL) tonnage shown on the die block being used. If the Working Load Limit is not legible, refer to Die height & width and corresponding Working Load Limit (See Table 1). Failure to do so can result in serious injury or death.

TABLE 1

Die Size (Height x Width)	Working Load Limit (WLL)*
2" x 3-1/2"	200 Ton Mark Series
2-1/2" x 4"	200 Ton National
2-1/2" x 5"	500 Ton Mark Series
4" x 7"	1,200 Ton Mark Series
5" x 7"	1,500 Ton National
6" x 12"	3,000 Ton National

\* Note: These Working Load Limits are for Crosby® National Die Blocks only. The Working Load Limits of die blocks from other manufacturers may vary.

## Inspection Maintenance Safety

- Make sure all bolts and nuts are in place and tightened to recommended torque as shown in Table A, on page 13 for new style swaging machines, and Table B on page 14 for legacy swaging machines.
- Load block or die base plate surfaces must be to manufacturers specifications for thickness and flatness to provide complete support of the die during swaging.
- Make sure die holder side rails are not bent, loose or damaged.
- Clean dies and die holder surfaces. Keep free of metal shavings, slag, grit, sand, floor dry, etc.
- Lubricate the four guide bushings daily with light oil.
- Inspect the rods for corrosion. Use #000 emery cloth or steel wool to maintain a high polish surface.
- Do not increase the hydraulic system pressure above the factory preset pressure of: 6500 psi for 500 ton, 1000 ton and 1500 ton swaging machines – 5000 psi for 3000 ton swaging machine.
- Under ordinary operating conditions, drain and clean reservoir every two (2) years.
- Filters inside of the reservoir should be cleaned every time the reservoir is drained and cleaned. The Racine “tell-tale” suction filter should be cleaned every six (6) months.

### Die Working Load Limit Pressure Adjustment on Lower Cylinder National 500 Ton through 1500 Ton Swaging Machines

Follow this procedure to adjust swaging tonnage (pressure) on your swaging machine.

1. Install the die holder(s) or die adapter with the dies to be used.
2. Bring the dies together (without a part in the dies) until they just touch.
3. Turn the tonnage control valve, which is located on the control panel left of the tonnage gauge, counter-clockwise about (6) six turns or until knob no longer turns.
4. Now (without a part in the dies) apply pressure to the dies by pressing the foot pedal marked “up”.
  - A. If the tonnage is lower than desired Working Load Limit, turn the valve clockwise while continuing to press the foot pedal marked “up” until desired Working Load Limit is reached.
  - B. If tonnage is higher than desired Working Load Limit, release pressure by pressing the pedal marked “down.” Then repeat steps 2 through 4.

### Die Working Load Limit Pressure Adjustment on 3000 Ton Swaging Machine

For reducing tonnage, use selector switch on front of control panel to select lower tonnage (approximately 1500 Tons) or 3000 Ton.



ALWAYS USE 5 X 7 OR 6 X 12 DIES AT 1500 TON SETTING.



USE ONLY 6 X 12 DIES ON TONNAGE THAT EXCEEDS 1500 TONS.

### Swaging Machine Capacity Chart for Standard Round Sleeves and Buttons

Hydraulic Swaging Machine Size	Swaging Method	Die Size (in.)	Largest Fitting Allowed to be Swaged (in.)		
			S-505 Sleeve	S-506 Sleeve	S-409 Buttons
500 Ton	Full Die	Mark Series 2-1/2 x 5 4 x 5 5 x 7	1-1/2	1-1/4*	7/8
1000 Ton	Full Die	4 x 7 5 x 7	2-1/2	1-1/4*	1-1/4*
1500 Ton	Full Die	5 x 7 6 x 12	3-1/2	1-1/4*	1-1/4*
3000 Ton	Full Die	6 x 12	4-1/2	1-1/4*	1-1/4*

\* Largest size fitting available.

### Swaging Machine Capacity Chart for S-501 and S-502 Swage Socket

Hydraulic Swaging Machine Size	Swaging Method	Die Size (in.)	Largest Fitting Allowed to be Swaged (in.)
500 Tons	Full Shank	Mark Series 2-1/2 x 5 4 x 7 5 x 7	3/4
	Progressive	4 x 7 5 x 7	1-1/4
1000 Tons	Full Shank	4 x 7 5 x 7	1
	Progressive	4 x 7	1-1/2
1500 Tons	Full Shank	5 x 7 6 x 12	1-1/4
	Progressive	5 x 7 6 x 12	2
3000 Tons	Full Shank	6 x 12	2*
	Progressive	6 x 12	2-1/2

\* Largest size fitting available.

# NATIONAL HYDRAULIC SWAGING MACHINE TORQUE MAINTENANCE INFORMATION

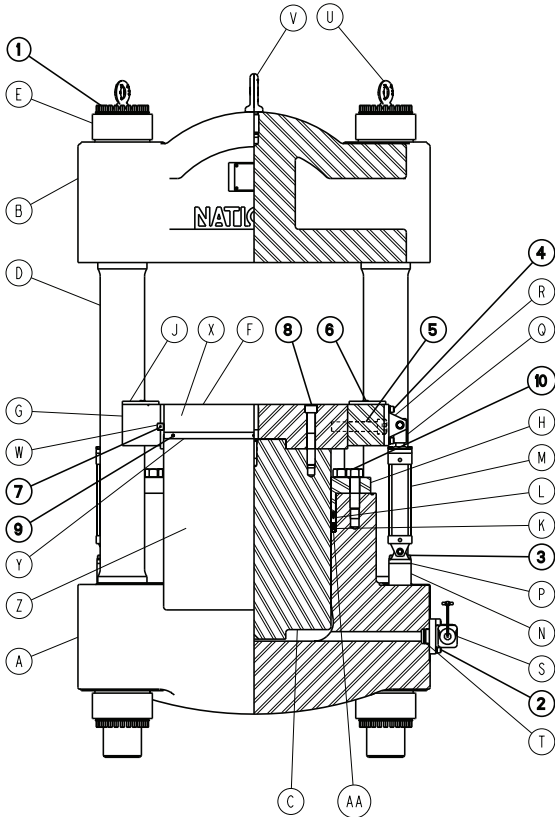

Item	No. Req'd.	Description
A	1	Cylinder
B	1	Housing Cap
C	1	Piston
D	4	Tie Rod
E	8	Tie Rod Nut
F	1	Platen
G	2	Guide
H	1	Gland
J	4	Bushing
K	1	Mono Seal
L	1	Seal Spacer
M	2	Side Cylinder
N	2	Side Cylinder Mount
P	2	Lower Bracket
Q	2	Knuckle
R	2	Upper Bracket
S	1	Check Valve
T	1	Check Valve Seal
U	4	Tie Rod Eyebolt
V	1	Cap Eyebolt
W	4	Key
X	2	Bumper
Y	2	Bumper Strip
Z	2	Rubber Skirt
AA	1	Bottom of Seal Cavity

Item No.	No. Req'd.	Description	Torque in Ft-Lbs			
			500 Ton Swaging Machine	1000 Ton Swaging Machine	1500 Ton Swaging Machine	Maintenance Schedule
1	Varies	Tie Rod Nut Jack-Bolts	105	N/A	260	Weekly
2	4	Check Valve Bolts	100	100	100	Weekly
3	8	Lower Bracket Bolts	100	100	100	Weekly
4	8	Upper Bracket Bolts	100	100	100	Weekly
5	4	Guide Bolts	250	250	250	Weekly
6	8	Bushing Screws	15	15	15	Weekly
7	4	Key Screws	4	4	4	Weekly
8	4	Platen Bolts	525	600	700	Monthly
9	6	Bumper Screws	4	4	4	Monthly
10	12	Gland Bolts	700	800	800	Monthly

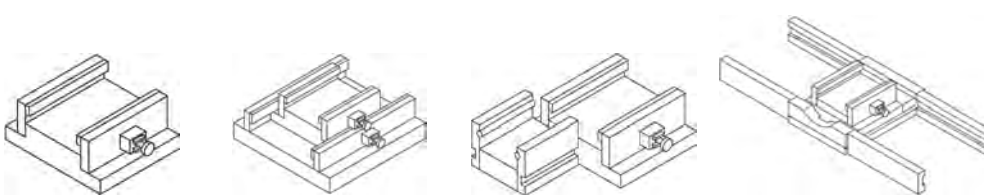

Torque in ft./ lbs.	
Die Holder	1/4 - 20 UNC 13
Bolt Torque	5/16 - 18 UNC 15
	5/8 - 11 UNC 211
	7/8 - 9 UNC 583

# NATIONAL LEGACY HYDRAULIC SWAGING MACHINE TORQUE MAINTENANCE INFORMATION

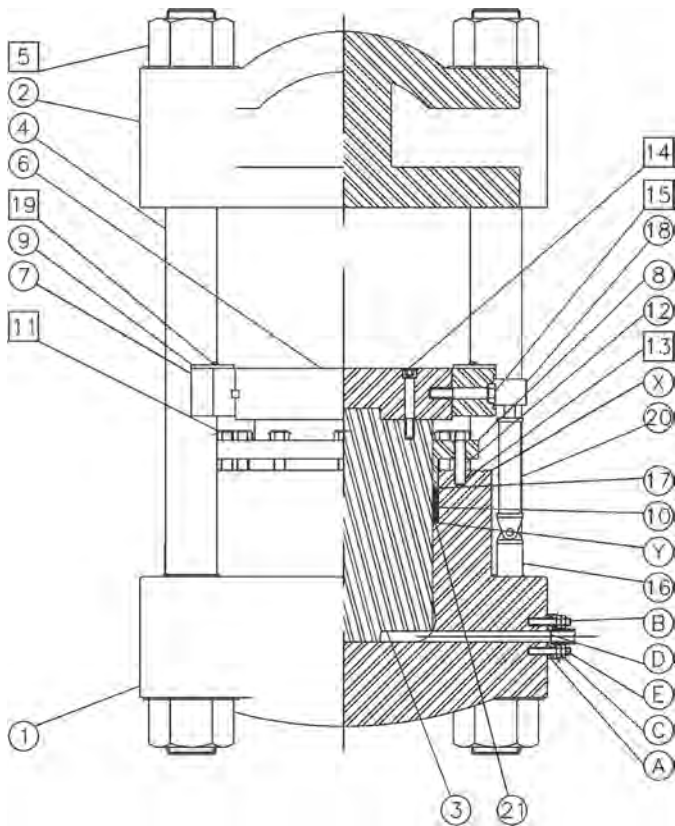

Item	No. Req'd.	Description
1	1	Cylinder
2	1	Housing Cap
3	1	Piston
4	4	Tie Rod
5	8	Nut
6	1	Platen
7	2	Guide
8	1	Gland
9	4	Bushing
10	1	Packing Set
11	12	Packing Gland Nut
12	4	Packing Gland Spacer
13	12	Stud
14	4	Cap Screw
15	4	Cap Screw
16	2	Lower Bracket
17	1	Upper Bronze Ring
18	2	Upper Bracket
19	8	Machine Screw
20	2	Side Cylinder
21	1	Lower Bronze Ring
A	1	Block
B	4	Stud
C	4	Nut
D	1	Copper "O" Ring
E	4	Lock Nut
X	1	Top of Cylinder
Y	1	Bottom of Packing Cavity

**Table A**

Item No.	Description	Torque in Ft. Lbs.				Maintenance Schedule
		500 Ton Swaging Machine	800 Ton Swaging Machine	1000 Ton Swaging Machine	1500 Ton Swaging Machine	
5	Tie Rod Nuts	2000	2250	2500	2500	Weekly
14	Piston Bolts	525	600	600	700	Monthly
11	Packing Gland Nuts (over spacers only) "all others hand tighten"	200	200	200	200	Weekly
15	Platen Guide Bolts	250	250	250	250	Weekly
13	Packing Gland Bolts	700	800	800	800	6 Months
	Side Cylinder Bolts	100	N/A	100	150	Weekly
19	Guide Bushing Bolts	15	15	15	15	Weekly
80 M Piston Pump Pistons		96 to 125 all Swaging Machines				

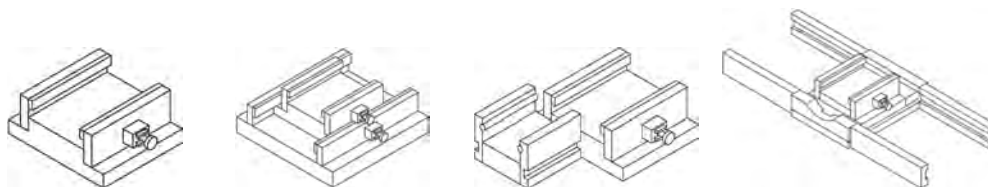

Torque in ft./ lbs.	
Die Holder	1/4 - 20 UNC 13
Bolt Torque	5/16 - 18 UNC 15
	5/8 - 11 UNC 211
	7/8 - 9 UNC 583

## Die Information

### CAUTION

- **Improper die selection could result in significant loss of efficiency in the termination.**

National dies and die holders are made solely for swaging properly designed fittings on wire rope, and any other uses are prohibited.

The swaging operation results in a high degree of cold metal flow. The movement that occurs between the fitting and the dies will cause wear of the dies. Therefore, to prolong the life of the dies, it is important to always lubricate die faces and cavities between each pass with a light weight oil or high pressure grease.

When scores appear in the die cavities, the dies should be removed from service.

### **NEVER EXCEED THE WORKING LOAD LIMIT OF DIES OR DIE HOLDERS.**

All National Standard dies 1/4" through 1" include an open channel die cavity and a tapered die cavity in the same die block.

### **Dies for S-505 Standard Steel Sleeves (Flemish Eyes)**

#### *Die sizes for 1/4" through 1"*

Swaging 1/4" through 1" Standard Steel S-505 sleeves on Flemish Eye terminations requires the use of the taper cavity only. Refer to page 24 of the *Wire Rope End Termination User's Manual* for proper die selection.

#### *Die sizes for 1-1/8" and above*

Swaging 1-1/8" and larger Standard Steel S-505 sleeves on Flemish Eye terminations requires using 2 sets of open channel dies (1st stage and 2nd stage) for each size. Beginning with the 1st stage die and finishing with the 2nd stage die will achieve proper after swage dimensions. Dies for S-505 Sleeves 1-1/8" and larger are single cavity with open channel. Refer to page 24 of the *Wire Rope End Termination User's Manual* for proper die selection.

#### Using S-505 Sleeves with Metric Ropes

Although Crosby National S-505 Standard Steel sleeves are designed to be used with most metric ropes, there are selected "intermediate" sizes of metric ropes that when swaged in standard National dies utilizing Crosby National S-505 sleeves do not achieve required after swage dimensions and efficiencies. To ensure all S-505 sleeves achieve the required efficiency when used with metric ropes, Crosby provides special National swaging dies to be used in conjunction with selected size metric ropes. These new dies will produce the required efficiencies and after swage dimensions.

The table found on Page 24 of the *Wire Rope End Termination User's Manual* identifies the new dies that are required to properly swage the selected intermediate size wire ropes not covered in the standard product offering found on Page 25 of the manual.

*Dies for 6mm through 26mm (except 12mm, 20mm and 24mm)*

Swaging on 6mm through 26mm metric ropes for Flemish Eye slings requires the selection of the proper S-505 Standard Steel sleeve and the use of the tapered cavity only. Refer to page 24 of the *Wire Rope End Termination User's Manual* for proper sleeve and die selection.

*Dies for 12mm, 20mm and 24mm*

Swaging on 12mm, 20mm and 24mm metric ropes for Flemish Eye slings requires the selection of the proper S-505 Standard Steel sleeve and the use of both the open cavity and tapered cavity in special dies. Refer to page 25 of the *Wire Rope End Termination User's Manual* for proper sleeve and die selection.

*Dies for 28mm and larger*

Swaging on 28mm and larger metric ropes for Flemish Eye slings requires the selection of the proper S-505 Standard Steel sleeve and the use of 2 sets of open channel dies (1st stage and 2nd stage) for each size. Beginning with the 1st stage die and finishing with the 2nd stage die will achieve proper after swage dimensions. Dies for S-505 sleeves 28mm and larger are single cavity with open channel. Refer to page 24 and 25 of the *Wire Rope End Termination User's Manual* for proper sleeve and die selection.

Important: If the specific size metric rope required is not listed on page 24 of the *Wire Rope End Termination User's Manual* refer to Intermediate Metric Die Chart on page 25 of the manual for proper sleeve and die selection.

*Dies for QUIC-PASS® Swaging System – 1/4" through 1-1/2"*

The QUIC-PASS® swaging system allows "Flemish style" wire rope terminations to be swaged in only two passes. This is accomplished while maintaining currently published efficiency ratings and utilizing National Swage S-505 Standard "COLD TUFF"® Steel Sleeves.

The special design of the QUIC-PASS® dies allows the swaging process to be completed in just two passes, resulting in a 50-75% reduction in the number of passes required with conventional swaging systems. Unlike standard round dies, the QUIC-PASS® dies close completely with each pass, resulting in an increase in overall swaging process efficiencies (the job can be performed quicker), a reduction in the complexity of swaging (the concern for excess flashing between dies has been eliminated) and a reduction in training time needed for operators (more user friendly).

The finished sleeve has a "Hex" appearance that provides a QUIC-CHECK® look to determine if the termination has been swaged and provides a flat surface that allows for ease of I.D. stamping on the finished sleeve. Refer to page 24 of the *Wire Rope End Termination User's Manual* for proper die selection.

### Dies for S-501 & S-502 Swage Sockets

Swaging all S-501 & S-502 Swage Sockets requires the use of single cavity die. This is a special die designed with a relief for swage sockets and extra length to swage the full length of the shank. Refer to pages 36 and 37 of the *Wire Rope End Termination User's Manual* for proper die selection.

#### Swage Sockets for Spiral Strand Rope

Our tests indicate that if the spiral strand is 1 x 19 or greater, and the ultimate strength does not exceed Table 4 of ASTM A586, you can use dies for size swage sockets up to the 1-1/4". For sizes greater than 1-1/4" the following table will apply:

If the strand is of greater strength than Table 4 or has less metallic area, we must recalculate the design and test for adequacy.

### Dies for S-506 Turnback Sleeves

Turnback eye terminations using 5/16" through 1" S-506 Sleeves utilize the S-505 Standard Steel Sleeve die (1st Stage open channel die only). The 1-1/4" S-506 Sleeve utilizes the 1-3/8" socket (S-501 and S-502) die. Refer to page 46 of the *Wire Rope End Termination User's Manual* for proper die selection.

### Dies for S-409 Buttons

Buttons are swaged in open channel dies. Refer to page 43 of the *Wire Rope End Termination User's Manual* for proper die selection.

Specific recommended swaging practices can be found in each product section of this manual. The proper die selection and the recommended maximum after swage dimensions are referenced in the section of this manual that contains the product you are swaging. This information can also be found in The Crosby General Catalog (See Section "Wire Rope End Terminations"), the National Swage Die Guide, or by referring to the National Swage Die Chart.

Dies and die adapters to fit other type swaging machines are available upon request (Refer to page 19).

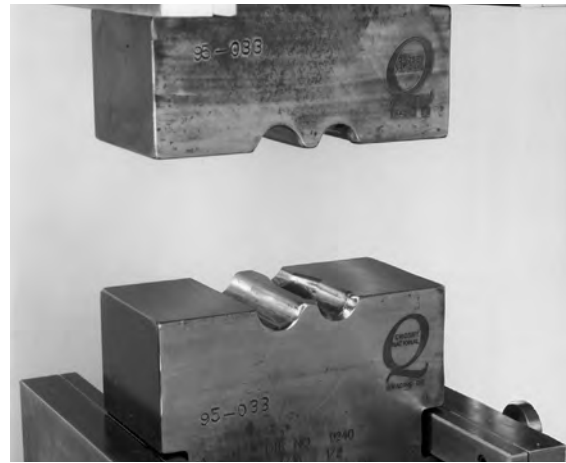

Two Cavity Die



Never use dies that are cracked, worn or abraded (galled).



Single Cavity Die

## After Swage Inspection Procedures

### **WARNING**

- Read, understand, and follow these instructions before using the National QUIC-PASS® Swaging System.
- Improper after swage dimensions can result in sling failure resulting in property damage, serious injury or death.
- Always gauge or measure the after swage dimensions to ensure proper sling performance.
- Using National Swaging System with ropes and termination styles other than shown in these procedures may reduce the performance of the termination and lead to premature failure.
- When using rope constructions other than shown in this procedure, the termination must be destructive tested and documented to prove adequacy of the assembly to be manufactured.
- The QUIC-PASS® Swaging System is designed only for “Flemish Eye” terminations using National S-505 Standard Steel Sleeves.
- The QUIC-PASS® Swaging System is not designed for Cable-Laid wire rope slings.

### Checking Swaging Dimensions

One of the important considerations in producing a quality termination is the overall diameter of the fitting after the swaging process is complete. Since all dies wear, and the swaged fitting used in terminations have spring back, the results of swaging should be checked periodically to determine the wear condition of the die as well as to ensure the fitting is swaged to proper dimensions.

### Key Facts About After Swage Dimensions:

1. In addition to worn dies, not achieving the proper after swage dimension can also be due to the die not being fully closed during swaging. Dies showing excessive wear should be replaced.
2. The effective swaging that dies can accomplish stops when the die lands touch each other. Any continued swaging adds needless wear and strain on the dies and swaging machine.
3. By placing a light oil on the die faces and in the cavity, the dies will be lubricated as well as protected.
4. The oozing of the oil from the faces of the dies as they touch will indicate when the dies have closed. At this point, stop the swaging cycle.
5. Additional swaging adds needless wear and strain to the dies and swaging machine.
6. Never use dies that are cracked, worn or abraded (galled).
7. The Crosby Group does not recommend the checking of die dimensions as an acceptable method of determining the quality of a swage sleeve, button, ferrule, or socket.
8. It is our recommendation that the checking of the after swage dimension of the swaged fitting is the most accurate indicator of a properly swaged termination. Measuring the die cavity only is not an acceptable process control check.
9. If the die cavity wears, the dies are not closed completely during swaging. If an inadequate number of presses are used, it could be quickly identified by checking the after swage dimension of the part.
10. Swaging Machine not producing sufficient tonnage will affect after swage dimensions.

### No-Go Gauge Information

To assist in checking the after swage dimensions of the fitting, the Crosby Group provides the National No-Go Gauges. When used correctly the National No-Go Gauges can determine if the fittings were swaged to the proper diameter. We would recommend that all Crosby products or product swaged in Crosby dies be checked with the proper gauge to determine the acceptability of the swaging process.

- Gauges are made of hardened alloy steel and machined to strict tolerances.
- Gauge can be used to verify that all fittings have been swaged properly.
- After swage dimensions not within the maximum limits may result from worn dies or improper swaging techniques.
- Other type gauges are available upon request.
- National No-Go Gauges are available for a variety of products (See Table 1).
- **No-Go Gauges and QUIC-PASS® No-Go Gauges are not interchangeable.**

Table 1	
Fitting and Size	Part No.
505 Sleeve 1/4 - 7/8	1095512
505 Sleeve 1 - 1-1/2	1095521
505 Sleeve 1-3/4	1095530
505 Sleeve 2	1095549
505 Sleeve 2-1/4	1095558
505 Sleeve 2-1/2	1095587
505 Sleeve 2-3/4	1095576
505 Sleeve 3	1095565
505 Sleeve 3-1/2	1095594
505 Sleeve 3-3/4	1095601
505 Sleeve 4	1095610
501/502 Socket 1/4 - 1	1095647
501/502 Socket 1-1/8 - 1-3/4	1095656
501/502 Socket 2	1095665

### Using No-Go Gauges

When swaged properly, the gauge will go up and down (see Figure 1) and around the full length of the fitting (see Figure 2).

For the proper after swage dimensions, see the section in this publication for the specific product you are swaging.



Figure 1



Figure 2

## QUIC-PASS® No-Go Gauges

As a further aid, QUIC-PASS® No-Go gauges are available for checking the sleeve's dimensions after swaging is complete.

- Gauges are made of hardened alloy steel and machined to strict tolerances.
- Gauge can be used to verify that all sleeves have been swaged properly.
- "After Swage" dimensions not within the maximum limits may result from worn dies or improper swaging techniques.
- **No-Go Gauges and Quic-Pass® No-Go Gauges are not interchangeable.**

QUIC-PASS® No-Go Gauges	
Sleeve and Size	Stock No.
No-Go Gauge for S-505 1/4" - 7/8"	1923705
No-Go Gauge for S-505 1" - 1-1/4"	1923712
No-Go Gauge for S-505 1-3/8" - 1-1/2"	1923714

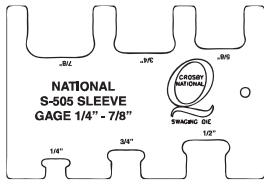

Stock No.  
1923705

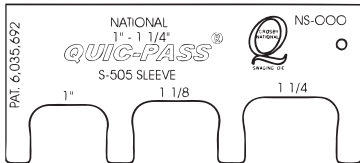

Stock No.  
1923712

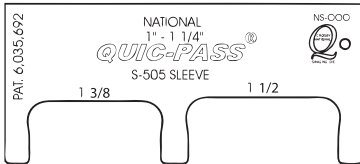

Stock No.  
1923714

Use a National QUIC-PASS® No-Go Gauge to check the after swage dimensions to ensure that it has been swaged to the proper dimension. When swaged properly, the gauge will slide up and down the full length of the sleeve on all three sets of opposing flats.

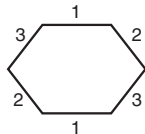

## QUIC-PASS® Maximum After Swage Dimensions

Size	Maximum "After Swage" Dimension (in.)
1/4	0.565
5/16 - 3/8	0.769
7/16 - 1/2	1.016
9/16 - 5/8	1.247
3/4	1.475
7/8	1.738
1	1.955
1-1/8	2.170
1-1/4	2.405
1-3/8	2.610
1-1/2	2.835

## Important Safety Information

- Crosby does not recommend a "Texas Tuck" style termination with Crosby National S-505 "COLD TUFF®" Standard Steel Sleeves.
- Only Crosby National S-505 "COLD TUFF®" Standard Steel Sleeves are recommended when using the QUIC-PASS® Swaging System.
- National S-505 Standard Steel Sleeves, when used with the QUIC-PASS® Swaging System, are only recommended for use with one (1) part 6 X 19 or 6 X 37, IPS or XIP (EIP), XXIP (EEIP), RRL, IWRC rope.
- The condition of the swaging machine can cause sleeve "After Swage" size not to be within the proper dimensions. Example: worn bushings, loose tie rods, loose die holders, misaligned platens, worn pins, worn linkage, etc.
- Swaging dies being worn, damaged, misused, or undersized can cause sleeve "After Swage" size not to be within the proper dimension.
- Swaging die holders excessively worn, damaged, misused or loose can cause sleeve "After Swage" size not to be within the proper dimension. Only use QUIC-PASS® dies and die holders inspected and properly secured in National swaging machines.
- Always refer to Warning and Application information found in the *Crosby General Catalog* and *Wire Rope End Terminations User's Manual*

# Die Information

## Optional Adapters

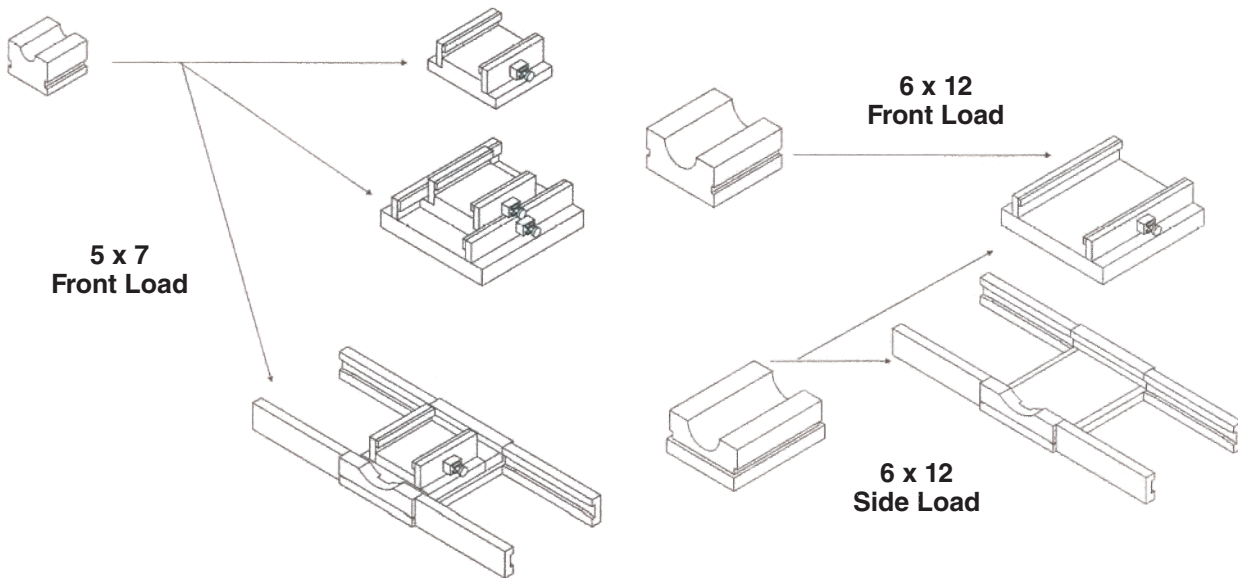

\* Special dies and adapters available upon request.

Proper die selection and after swage dimensional information can also be found in the following Crosby® sources.

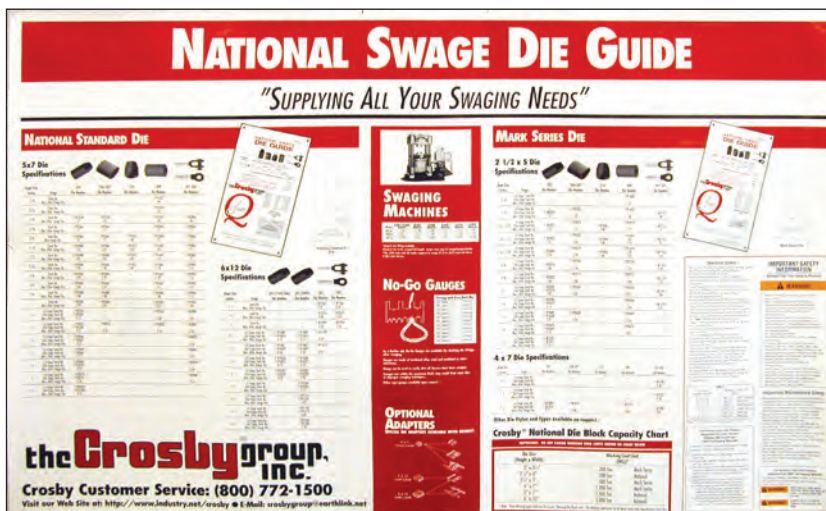

National Swage Die Guide Chart



Crosby General Catalog



National Swage Die Guide

# Die Information

The National Swage Die Guide was developed to aid in determining which dies are required for swaging the various sizes and types of products manufactured by National Swage.

Side 1 of the Die Guide is to be referenced when working with National Standard Dies.

Side 2 of the Die Guide is to be referenced when using Mark Series Dies.

**IMPORTANT:** Be sure to reference the correct information (side 1 or side 2) for your particular swaging application.

**NATIONAL SWAGE DIE GUIDE**

**SIDE 1**

FITTING SIZE	STAGE	505		510	501-502	
		DIE NO.	DIE NO.	DIE NO.	DIE NO.	DIE NO.
7/16-1/2"	1ST	1192408		1191643		
	2ND	1192408	1197423	1.03	1192881	
		1.01	1.03	1.08	1.16	0.91

**MAXIMUM AFTER SWAGE DIAMETER**

**INSTRUCTIONS:**  
 1. Set FITTING SIZE in window.  
 2. Read **MAXIMUM AFTER SWAGE DIAMETER** and DIE SIZE and TYPE.

**WARNING: DO NOT EXCEED DIE WLL. CONTACT DIE MANUFACTURER FOR WLL.**

**DIE SIZE**  
5X7 STD

**DIE TYPE**

**Crosby**  
 NATIONAL SWAGE

**NATIONAL STANDARD DIE**

DIE NO. 9266  
 1 3/8" - 1 1/2" S-505  
 DIE BLOCK WLL 600 TONS  
 ADJUST TONNAGE TO WLL

96-195

*"When buying Crosby, you're buying more than product, you're buying Quality"*

## USING THE NATIONAL SWAGE DIE GUIDE

An example of how to use the Die Guide would be if you needed to swage a 1/2" S-501 Swage Socket in National Standard Dies. First, find the 7/16 -1/2" fitting size designation, and follow that row across the different product types to the column heading 501 - 502 Die No.

You can see that the required Die No. is 1192881 and the size and type is 5 x 7 Std. When you have located and verified that you have the correct dies, you are ready to begin the swaging process. You can also find the maximum after swage dimension listed below the corresponding Die No. (i.e. 0.91)

Remember, side 1 refers to National Standard Dies and side 2 refers to Mark Series Dies.

# COLD TUFF® Swage Fittings – Introduction



A number of years ago, we met the challenge of making swage fittings, including sleeves, sockets and buttons more reliable during adverse swaging conditions. At that time sleeves tended to crack during the swaging process – especially at lower temperatures.

Our research in materials, and the development of a unique thermal process resulted in the development of COLD TUFF® swage fittings. This name was derived from the ability of these new materials to cold flow plastically (a definition of swaging) in the presence of a notch at extremely low temperatures.

The success of COLD TUFF® swage fittings in overcoming problems encountered in swaging has revolutionized the industry. The result of the COLD TUFF® process has made National Swage fittings stronger. National S-505 Standard Steel sleeves have outperformed stainless steel sleeves on wire rope eye terminations in the classic 90 degree angle between the rope legs of sling eye test – and for a fraction of the cost of a stainless steel sleeve.

Also, COLD TUFF® swage products can be impression stamped after swaging for identification purposes. Properly done, there should be no concern for fractures initiating from such impressions. Specific recommended stamping procedures can be found in each product section.

## Key Facts About Swaging:

1. Crosby's proprietary COLD TUFF® heat treat process has made swaging more reliable during the demanding conditions of swaging.

2. COLD TUFF® virtually eliminates the cracking during the swaging process, especially at extremely low temperatures.
3. The steel microstructure created from the COLD TUFF® heat treatment process reveals a uniform structure in the Crosby fittings that result in Charpy impact values averaging up to ten times greater than those of competitive products.

## Un-retouched Photomicrographs of Sleeve (Original Magnification @ 500x)

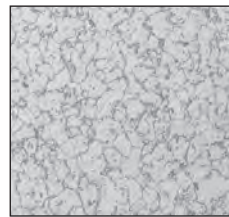

### Crosby COLD TUFF® Heat Treatment

The *uniform* microstructure of the COLD TUFF® process results in superior ductility and toughness properties.

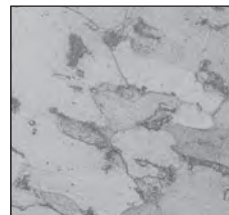

### Competitor's Heat Treatment

The non-uniform microstructure may lack proper ductility and toughness required for swaging and use.

4. The improved steel microstructure provides increased resistance to cracks that can occur during the sling building process. Cracks are initiated at stress risers.
5. Crosby COLD TUFF® sleeves dramatically reduce the effects of stress risers that can occur during swaging where the "cold worked" sleeve makes contact with the wire. Stress risers are not detectable through visual inspection.
6. Because of the higher Charpy values found in Crosby COLD TUFF® sleeves, stress risers caused by stenciling are not detrimental.
7. Crosby or CG and COLD TUFF® are clearly stenciled on every sleeve we make (legible even after swaging) leaving no question as to the quality or the manufacturer.

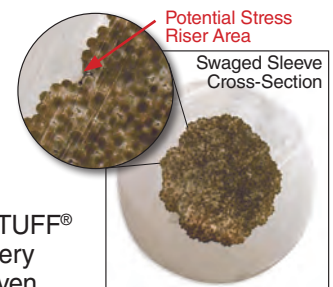

COLD TUFF® process results in superior ductility that reduces the effects of stress risers.

# COLD TUFF® Swage Fittings – S-505

## Swaging Methods for S-505 Sleeves

(Carbon Steel Sleeve for Flemish Eyes)

National S-505 carbon steel sleeves are specially designed for use with Flemish Eyes and for swaging in National dies.

These swage fittings are designed to be used on one (1) part of 6 x 19 or 6 x 37 FC IPS or IWRC EIPS Right Regular Lay wire rope.

**Before using any National Swage fitting with any other type lay, construction or grade of wire rope, it is recommended that the termination be destructive tested and documented to prove the adequacy of the assembly to be manufactured.**

## Cold Swaging Process

Cold swaging is a process which causes considerable movement and work hardening of the steel in the fitting. Exerting extreme pressures, the swaging machine forces the steel to flow into the crevices between the wires and strands of the wire rope. At the same time, the swaging machine forces the material to flow plastically along the length of the wire rope. These are a few of the reasons swaging is done on steel fittings in multiple passes in a well lubricated die.

## Protecting Dies and Swaging Machines

When the die lands touch each other, effective swaging stops. Additional swaging adds needless wear and strain on the dies and swaging machine. We recommend placing oil on the die faces and cavities. When swaging, the oozing of the oil from the die faces will indicate when the dies are closed. At this point, stop swaging.

## Avoid Excess Flashing

Flashing occurs when sleeve material flows out into the area between the die faces. Once formed, additional passes will not eliminate flashing. They will only fold back the flash and develop a permanent mark in the material and possibly create a crack.

Flashing is not an issue with QUIC-PASS® system, as each pass requires full closure of the dies.

**To avoid excess flashing, do the following:**

- Select proper dies.
- Make sure that dies are in good condition and properly lubricated.
- Apply lubricant such as a light hydraulic oil to both die cavities and the lower die face.
- Follow swaging instructions on pages 27-35.



## Identification Stamping

For identification purposes, National COLD TUFF® swage products can be impression stamped after swaging. Properly done, there should be no concern for fractures initiating from such impressions.

**To stamp S-505 Sleeves:**

- Use round corner or low stress stamps. Stamp to maximum depth of 0.015 in. (1/64”).
- Stamp in area on the side of the sleeve in the plane of the sling eye, and no less than 0.250 in. (1/4”) from either end of the sleeve.



**NOTE:**

WHEN USING NATIONAL QUIC-PASS® DIES, THE FINISHED SLEEVE HAS A “HEX” APPEARANCE THAT PROVIDES A QUIC-CHECK® LOOK TO DETERMINE IF THE TERMINATION HAS BEEN SWAGED, AND PROVIDES A FLAT SURFACE THAT ALLOWS FOR EASE OF I.D. STAMPING ON THE FINISHED SLEEVE.

# National Steel Swaging Sleeves



S-505

- For Flemish Eye wire rope splicing.
- Designed for low temperature toughness.
- Resists cracking when swaged (equals or exceeds stainless steel sleeves).
- Special processed low carbon steel.
- "COLD TUFF<sup>®</sup>" for better swageability.

S-505 Termination Efficiency		
Size (in.)	Type of Wire Rope*	
	IWRC	FC
1/4 - 1	96%	93%
1-1/8 - 2	92%	89%
2-1/8 and Larger	90%	87%

\* NOTE: S-505 Standard Sleeves are recommended for use with 6 x 19 or 6 x 37, IPS or XIP (EIP), XXIP (EEIP), RRL, FC or IWRC wire rope.

Before using any National Swage fitting with any other type lay, construction or grade of wire rope, it is recommended that the termination be destructive tested and documented to prove the adequacy of the assembly to be manufactured.

The National Die Guide will assist you in selecting the proper dies to meet your swaging needs.

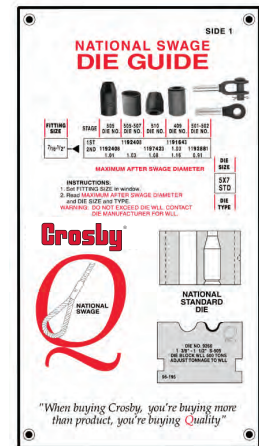

- Can be stamped for identification after swaging without concern for fractures when following these directions.
- Use round corner stamps to a maximum depth of 0.015 in. (1/64"). The area for stamping should be on the side of the sleeve in the plane of the sling eye, and no less than 0.250 in. (1/4") from either end of the sleeve.
- Standard Steel Sleeve terminations have efficiency ratings as follows based on the catalog strength of wire rope.

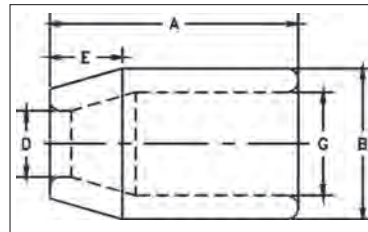

NOTE: See page 24 for dimensional information.

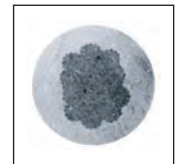

"Cross Section of Swaged Sleeve"

## QUIC-PASS<sup>®</sup>

National QUIC-PASS<sup>®</sup> Swaging System  
"The Next Generation in Swaging Systems"

The QUIC-PASS<sup>®</sup> swaging system allows "Flemish style" wire rope terminations to be swaged in only two passes. This is accomplished while maintaining currently published efficiency ratings and utilizing National Swage S-505 Standard "COLD TUFF<sup>®</sup>" Steel Sleeves.

- Allows the swaging process to be completed in just two passes, resulting in a 50-75% reduction in the number of passes required with conventional swaging systems.
- Allows the dies to close completely with each pass, resulting in...
  - An increase in overall swaging process efficiencies (the job can be performed quicker).
  - A reduction in the complexity of swaging (the concern for excess flashing between dies has been eliminated).
  - A reduction in training time needed for operators (more user friendly).
- The finished sleeve has a "Hex" appearance that provides a QUIC-CHECK<sup>®</sup> look to determine if the termination has been swaged and provides a flat surface that allows for ease of I.D. stamping on the finished sleeve.

# National Steel Swaging Sleeves

## S-505 COLD TUFF® Standard Steel Sleeves

												Swager / Die Data		
Rope Size		S-505 Stock No.	Weight Per 100 (lbs.)	Pkg. Qty.	Before Swage Dimensions (in.)					Maximum After Swage Dimensions (in.)		Standard Round Dies		QUIC-PASS Dies
(in.)	(mm)*				A	B	D	E	G	Standard Die	QUIC-PASS Die †	Die Description	Standard Die Stock No.	QUIC-PASS Die Stock No. †
1/4	6-7	1041063	5	250	1.00	.66	.31	.28	.47	.57	.565	1/4 Taper	1197528	1923530
5/16	8	1041090	14	200	1.50	.91	.44	.44	.62	.75	.769	3/8 Taper	1192364	1923551
3/8	9-10	1041107	14	100	1.50	.91	.47	.39	.66	.75	.769	3/8 Taper	1192364	1923551
7/16	11	1041125	33	50	2.00	1.22	.55	.65	.85	1.01	1.016	1/2 Taper	1192408	1923572
1/2	13	1041143	29	50	2.00	1.22	.63	.56	.91	1.01	1.016	1/2 Taper	1192408	1923572
9/16	14	1041161	64	25	2.75	1.47	.69	.63	1.03	1.24	1.247	5/8 Taper	1192444	1923593
5/8	16	1041189	56	25	2.75	1.47	.75	.63	1.09	1.24	1.247	5/8 Taper	1192444	1923593
3/4	18-19	1041205	88	20	3.19	1.72	.91	.84	1.28	1.46	1.475	3/4 Taper	1192462	1923614
7/8	22	1041223	131	10	3.56	2.03	1.03	1.00	1.53	1.68	1.738	7/8 Taper	1192480	1923635
1	25-26	1041241	195	10	4.00	2.28	1.16	1.13	1.72	1.93	1.955	1 Taper	1192505	1923656
1-1/8	28-29	1041269	260	Bulk	4.81	2.50	1.28	1.25	1.94	2.13	2.170	1-1/8 Open 1st Stage 2nd Stage	1192523 1192541	1923677
1-1/4	31-32	1041287	355	Bulk	5.19	2.78	1.44	1.41	2.16	2.32	2.405	1-1/4 Open 1st Stage 2nd Stage	1192621 1192587	1923698
1-3/8	34-35	1041303	423	Bulk	5.81	3.00	1.56	1.56	2.38	2.52	2.610	1-3/8 Open 1st Stage 2nd Stage	1192667 1192621	1923717
1-1/2	37-38	1041321	499	Bulk	6.25	3.25	1.69	1.69	2.63	2.71	2.835	1-1/2 Open 1st Stage 2nd Stage	1192649 1192667	1923736

												Swager / Die Data				
Rope Size		S-505 Stock No.	Weight Per 100 (lbs.)	Pkg. Qty.	Before Swage Dimensions (in.)					Maximum After Swage Dimensions (in.)	Die Description	Stock No.				
(in.)	(mm)				A	B	D	E	G			500 Tons 1000 Tons 1500 Tons 5x7	Front Load		Side Load	
										1500 Ton 6x12	3000 Ton 6x12	1500 Ton 6x12	3000 Ton 6x12			
1-3/4	44-45	1041349	805	Bulk	7.25	3.84	1.94	1.97	3.13	3.10	1-3/4 Open 1st Stage 2nd Stage	1192685 1192701	—	—	—	—
2	50-52	1041367	1132	Bulk	8.50	4.38	2.25	2.25	3.63	3.56	2 Open 1st Stage 2nd Stage	1192729 1192747	—	—	—	—
2-1/4	56-57	1041385	1936	Bulk	9.56	5.03	2.50	2.53	4.03	4.12	2-1/4 Open 1st Stage 2nd Stage	1192765 1192783	1191089 1191043	1191089 1191043	—	1195085 1195067
2-1/2	62-64	1041401	2352	Bulk	10.50	5.50	2.75	2.81	4.50	4.50	2-1/2 Open 1st Stage 2nd Stage	—	1191061 1191089	1191061 1191089	1195370 1195469	1195076 1195085
2-3/4	68-70	1041429	2800	Bulk	11.50	5.75	3.00	3.09	4.75	4.70	2-3/4 Open 1st Stage 2nd Stage	—	1191034 1191052	1191034 1191052	1195389 1195478	1195094 1195101
3	75-76	1041447	2940	Bulk	12.00	6.00	3.25	3.38	5.00	4.96	3 Open 1st Stage 2nd Stage	—	1193201 1193229	1193201 1193229	1195398 1195487	1195110 1195129
3-1/2	87-89	1041483	4640	Bulk	14.00	7.00	3.88	3.94	5.84	5.77	3-1/2 Open 1st Stage 2nd Stage	—	1193247 1193265	1193247 1193265	—	1195138 1195147
3-3/4	93-95	1041492	5500	Bulk	15.00	7.50	4.06	4.25	6.31	6.23	3-3/4 Open 1st Stage 2nd Stage	—	—	1191114 1191132	—	1195263 1195272
4	100-105	1041508	6800	Bulk	16.00	8.13	4.38	4.50	6.81	6.69	4 Open 1st Stage 2nd Stage	—	—	1191150 1191178	—	1195156 1195165
4-1/2	112-114	1041526	10000	Bulk	18.00	9.13	4.88	5.06	7.66	7.45	4-1/2 Open 1st Stage 2nd Stage	—	—	1191187 1191203	—	1195174 1195183

# Intermediate Metric Die Chart

Sleeve and Swaging Die Requirements for Intermediate Sizes of Metric Wire Rope							
S-505 Stock No.	S-505 Sleeve Size	Metric Wire Rope Size	Standard Round Dies				Maximum After Swage Dimension
			1st Stage Die		2nd Stage Die		
			Die No.	Die Description	Die No.	Die Description	
1041143	1/2	12	1190881	5 x 7 Double Cavity	—	—	.990
1041223	7/8	20	1190901	5 x 7 Double Cavity	—	—	1.620
1041241	1	24	1190921	5 x 7 Double Cavity	—	—	1.880
1041321	1-1/2	36	1192649	5 x 7	1190941	5 x 7	2.630
1041349	1-3/4	40	1192685	5 x 7	1190961	5 x 7	2.950
1041367	2	48	1192729	5 x 7	1190971	5 x 7	3.460
1041401	2-1/2	60	1192809	5 x 7	1190981	5 x 7	4.370
1041401	2-1/2	60	1191061	6 x 12	1190991	6 x 12	4.370
1041487	3	72	1193201	6 x 12	1191001	6 x 12	4.810
1041483	3-1/2	80	1193247	6 x 12	1191101	6 x 12	5.450
1041483	3-1/2	84	1193247	6 x 12	1191121	6 x 12	5.550

QUIC-PASS® system not available for these metric rope sizes.

# Flemish Type Wire Rope Sling Eyes – Introduction

Flemish type wire rope sling eyes are formed by looping an eye (see information on pages 27-28 for forming eye properly) and cold swaging a steel sleeve on the rope at the base of the loop. Swaging bonds the ends of the rope strands in place by forming a streamlined, compact, solid and permanent splice. The Flemish wire rope sling eyes have all the advantages of a hand spliced eye with the added safety of a swaged steel sleeve to complete the termination while leaving no rope distortion, wire ends or chance of rope slippage due to rotation.

The Flemish Eye ensures equal distribution of the load in both parts of the eye because pull is directly along the center line of the rope and eye. Cold swaging the National S-505 Standard Steel Sleeve forms a solid bond around the splice which will achieve a breaking strength near the rated breaking strength of the wire rope, thus giving maximum efficiency of the termination (see page 23 for rated efficiencies).

The National S-505 COLD TUFF® Steel Sleeves are engineered to be cold swaged without failure (when proper swaging techniques as described on pages 27-35 are used) in both extreme hot or cold environments. One end of the sleeve is tapered to allow the splice to pass under obstructions without snagging. The other end has a radius which helps to eliminate rope abrading.

## Forming the Eye

In accordance with the Wire Rope Technical Board's Sling committee's recommendation, we endorse that a seven (7) lay rope eye will give maximum efficiency with no advantage in using more.

## Separating Rope Strands

Flemish Eyes are formed by separating the strand into two groups with the core and 3 strands in one group and 3 strands in the other group. (See page 28, Step 1.)

The stopping point for separating the strands determines the length of the strand ends at the throat of the splice. If the strand ends or pull amount are too short, relay the strands and insert one strand to the left. If the strand ends or pull are too long, move one strand to the right. See pages 27-28 for detail steps in marking and making a Flemish Eye.

## Important

The Flemish Eye for the QUIC-PASS® system is formed in the same manner as the standard round sleeves. See page 35 for detail steps in marking a QUIC-PASS® Flemish Eye.



*Swaged Flemish Eye Termination using a National S-505 "COLD TUFF®" Standard Steel Sleeve.*

# Flemish Type Wire Rope Sling Eyes – Marking

## Marking & Calculations for Forming Mechanical Spliced Flemish Style Eyes

### Calculation for Forming Different Size Eyes

Many methods have been used to form the Flemish Style Eye (i.e., from counting the number of lays to unlay to trial and error). The method used here is based on a mathematical formula that will produce the required results on the rope recommended by Crosby National Swage.

#### Standard Eyes

Pull amount or tail is equal to 3.75 X diameter (d) of rope. Throat amount is equal to 40 X diameter (d) of rope. See example below.

**Example:** Standard Eye for 1/2" wire rope

**Step 1:** To find the Pull Amount or tail, Mark 1 (See Figure 1).

Mark 1 = 3.75 X d (d is the diameter of the rope)

**Example:** Mark 1 = 3.75 X .5" = 1.875"  
(Diameter of Rope)

**Step 2:** To find the throat, Mark 2 (See Figure 2).

Mark 2 = 40.00 X d

**Example:** Mark 2 = 40.00 X .5" = 20.00"  
(Standard Throat Constant) (Diameter of Rope)

Measure from Mark 1

Total amount of rope to form Standard eye including tail (from end of rope) for Flemish style splice is 21.875"

#### Standard Thimble Eyes

Pull amount is equal to 3.75 X diameter (d) of rope. Throat amount is equal to 15 X diameter (d) of rope. See example below (change throat amount to 15).

#### Larger than Standard Eyes

Pull amount or tail is equal to 3.75 X diameter (d) of rope. Throat amount is equal to 5 X width of eye to be formed. Note: All standard eyes have a width of 1/2 the length (Example: 6" wide X 12" long eye).

Use assembly procedure for Flemish Eye on Page 28.

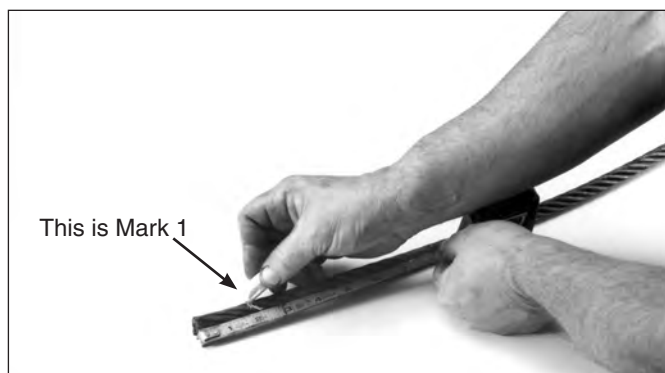

Figure 1

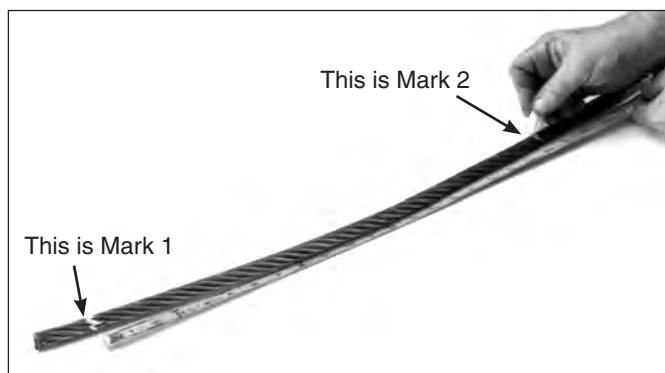

Figure 2

# Flemish Type Wire Rope Sling Eyes

## Fabrication Procedure for Mechanical Spliced Flemish Eyes

We recognize that there are other ways to produce a Flemish Eye. However, this is one way that can be employed.

Step 1: Transfer your marks 1 and 2 to your wire rope (See page 27 for instructions). Slide proper sleeve on rope and unlay the rope dividing it into 2 sections consisting of 3 strands and 3 strands plus the core. See page 23 for recommended rope to use.

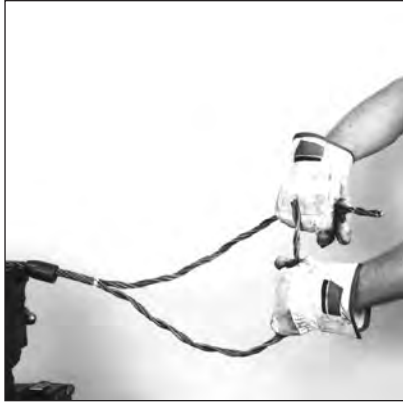

Step 2: Cross Mark 1 of the 3 strand group over the core group at Mark 2. Then bring the core group over the 3 strand group until they lock together in their natural configuration. Keep Marks 1 and 2 as close together as possible.

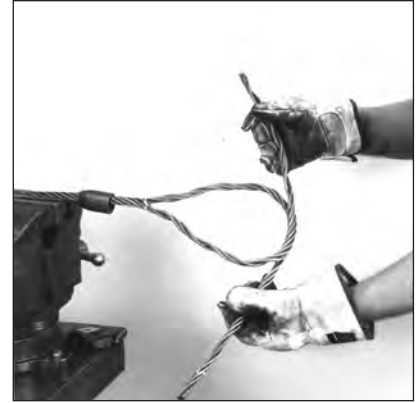

Step 3: Relay or cross over the core and strand group until eye is formed.



Step 4: Relay the rope completely, including tails, or pull amount of rope. Our tests have proven that when the tail's ends, or pull amount of rope you achieve the greatest efficiency. **Making Flemish Eyes by tucking the tail's ends, or pull amount, on the inside of the rope is not recommended (The Texas Tuck).**



Step 5: Slide sleeve over tail and make sure the sleeve is all the way upon tail before swaging. This can be easily achieved by using a flat bar or a hammer and driving the sleeve, from the nose end, until it is fully seated over the tail. The rope at the end of the sleeve should then be marked. This will allow you to determine if the sleeve has moved before and during swaging.

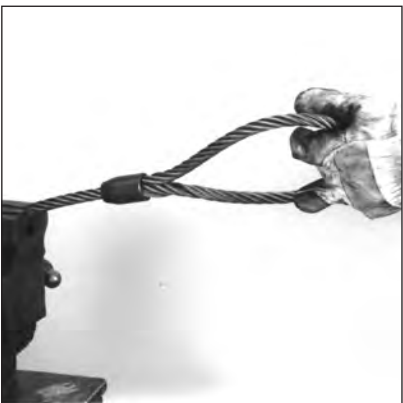

Step 6: Swage product using proper swaging methods on pages 29-35. Swage with proper dies to ensure required after swage dimension (see pages 24-25 in this manual, or look up proper die and maximum after swage dimensions in either The Crosby General Catalog, the National Swage Die Guide, or the National Swage Die Chart). Check the fitting with proper measuring devices or No-Go gauges to insure the correct swage dimensions. See pages 17-18 for proper way to check fittings after swage dimensions.

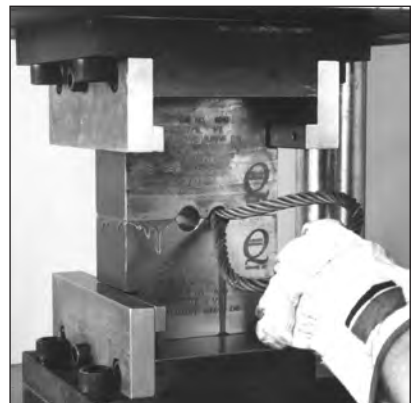

# Flemish Type Wire Rope Sling Eyes – 1/4" - 1"

Flemish Eye Terminations for 1/4" thru 1" National S-505 Sleeves. For larger sizes, see pages 31-34. Dies for National S-505 Standard Steel Sleeve, sizes 1/4" thru 1", are provided with two cavities. **National 1/4" through 1" S-505 sleeves are designed to be swaged only in the tapered cavity of a two cavity die in a National Hydraulic Swaging Machine.**

Step 1. Slide sleeve over rope.



Step 2. Assemble Flemish Eye. See page 28.



Step 3. Slide sleeve fully over ends of wire rope.



Step 4. Lubricate both die cavities and lower die face. See page 24 for proper die selection.



Step 5. 1st pass – allow dies to remain open approximately 1/2 the distance from time initial contact is made between sleeve and dies. Open dies and rotate fitting 45 to 90 degrees.



Step 6. 2nd pass – allow dies to remain open approximately 1/2 the distance from time initial contact is made between sleeve and dies. Open dies and rotate fitting 45 to 90 degrees.

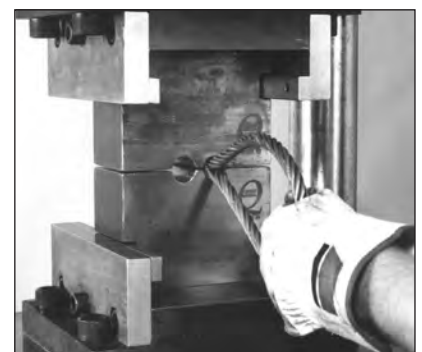

Step 7. 3rd pass – If sharp flashing does not occur, close die. Open dies and rotate fitting 45 to 90 degrees.



Step 8. 4th pass – Close dies to round fitting. Open dies and rotate fitting 45 to 90 degrees between passes. **Open dies and check for proper after swage dimensions** (See page 17 for proper use of No-Go Gauges).



Additional swaging may be required to provide smooth finish and achieve proper after swage dimensions.  
**Dies must be fully closed in tapered die cavity before swaging is complete.**

# Flemish Type Wire Rope Sling Eyes – 12mm, 20mm & 24mm

Flemish Eye Terminations for 1/2 – 1” National S-505 sleeves on 12mm, 20mm and 24mm metric ropes. For larger sizes see page 31-34. Special dies are required to swage National S-505 sleeves on 12mm, 20mm and 24mm wire ropes. The dies are provided with two cavities. **National 1/2” through 1” S-505 sleeves require swaging in the open cavity and then completing the swaging in the tapered cavity in a National Hydraulic Swaging Machines.**

Step 1. Slide sleeve over rope.



Step 2. Assemble Flemish Eye. See page 28.



Step 3. Slide sleeve fully over ends of wire rope.



Step 4. Lubricate both die cavities and lower die face. See page 24 for proper die selection.



Step 5. 1st pass – In open cavity, allow dies to remain open approximately 1/2 the distance from time initial contact is made between sleeve and dies. Open dies and rotate fitting 45 to 90 degrees.



Step 6. 2nd pass – allow dies to remain open approximately 1/2 the distance from time initial contact is made between sleeve and dies. Open dies and rotate fitting 45 to 90 degrees.

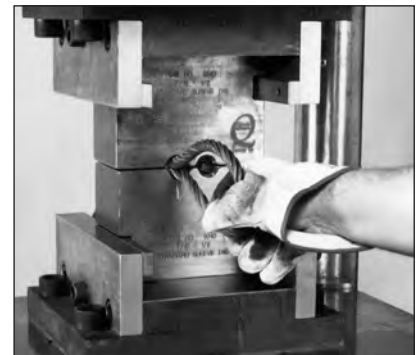

Step 7. 3rd through 6th pass – If sharp flashing does not occur, close dies. **Open dies. Move assembly to tapered cavity and repeat steps 5, 6 and 7.**



Step 8. 7th pass — Close dies to round fitting. Open dies and rotate fitting 45 to 90 degrees between passes. **Open dies and check for proper after swage dimensions** (See page 17 for proper use of No-Go Gauges).



Additional swaging may be required to provide smooth finish and achieve proper after swage dimensions.

**Dies must be fully closed in tapered die cavity before swaging is complete.**

# Flemish Type Wire Rope Sling Eyes – 1 $\frac{1}{8}$ " - 1 $\frac{3}{4}$ "

Flemish Eye Termination for 1-1/8" through 1-3/4" S-505 Sleeves. For other sizes, see pages 29-30 and 32-33. National S-505 Standard Steel Sleeve dies are provided with a 1st stage and 2nd stage die. **National S-505 Standard Steel Sleeves 1-1/8" and larger require swaging in the 1st stage die and completing the swaging in 2nd stage dies in a National Hydraulic Swaging Machine.**

## 1st STAGE

Step 1. Slide sleeve over rope.



Step 2. Assemble Flemish Eye. See page 28 for assembly instructions.



Step 3. Slide sleeve fully over ends of wire rope.



Step 4. Lubricate both die cavities and lower die face. See page 24 for proper die selection.



Step 5. 1st pass – allow dies to remain open approximately  $\frac{1}{2}$  the distance from time initial contact is made between sleeve and dies. Open dies and rotate fitting 45 to 90 degrees.



Step 6. 2nd pass – allow dies to remain open approximately  $\frac{1}{2}$  the distance from the time initial contact is made between the sleeve and dies. Open dies and rotate fitting 45 to 90 degrees.



Step 7. 3rd pass – allow dies to remain open approximately  $\frac{1}{2}$  the distance from the time initial contact is made between the sleeve and dies. Open dies and rotate fitting 45 to 90 degrees.



Step 8. 4th and 5th pass – If sharp flashing does not occur, close die. Open dies and rotate fitting 45 to 90 degrees between each pass.



# Flemish Type Wire Rope Sling Eyes – 1 $\frac{1}{8}$ " - 1 $\frac{3}{4}$ "

Swaging Instruction for Flemish Eye 1  $\frac{1}{8}$ " - 1  $\frac{3}{4}$ " Continued

**2nd Stage** – Lubricate both die cavities and lower die face. See page 24 for proper die selection.

Step 9. 1st pass – allow dies to remain open approximately  $\frac{1}{2}$  the distance from time initial contact is made between sleeve and dies. Open dies and rotate fitting 45 to 90 degrees.

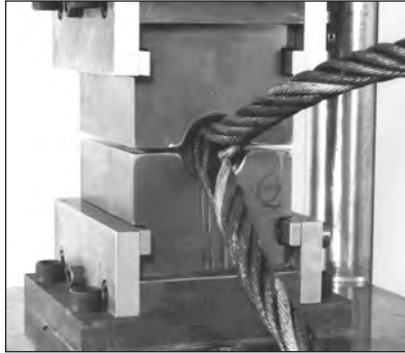

Step 10. 2nd pass – allow dies to remain open approximately  $\frac{1}{2}$  the distance from the time initial contact is made between the sleeve and dies. Open dies and rotate fitting 45 to 90 degrees.



Step 11. 3rd pass – allow dies to remain open approximately  $\frac{1}{2}$  the distance from the time initial contact is made between the sleeve and dies. Open dies and rotate fitting 45 to 90 degrees.

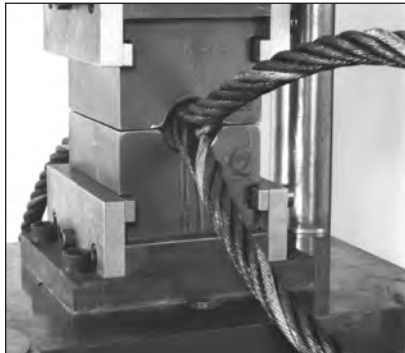

Step 12. 4th pass – If sharp flashing does not occur, close dies. Open dies and rotate fitting 45 to 90 degrees between each pass.

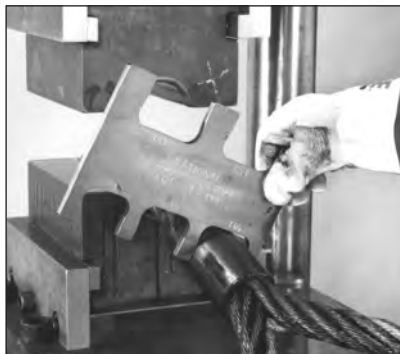
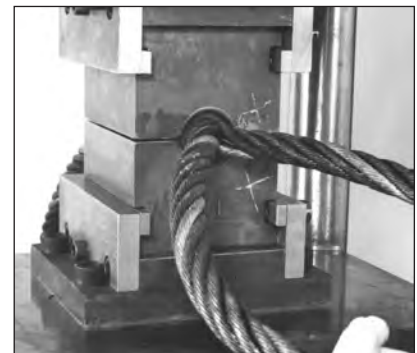

Step 13. 5th and 6th pass – Close dies to round fitting. Open dies and rotate fitting 45 to 90 degrees between each pass. **Open dies and check termination for proper after swage dimensions.** (See page 17 for proper use of No-Go Gauges).

Additional swaging may be required to provide smooth finish and achieve proper after swage dimensions.  
**Dies must be fully closed in 2nd stage die cavity before swaging is complete.**

# Flemish Type Wire Rope Sling Eyes – 2" & Larger

Flemish Eye Terminations for 2" and larger National S-505 Sleeves. For other sizes see pages 29-32. National Standard Steel Sleeve dies are provided with a 1st stage die and 2nd stage dies. **National S-505 Standard Steel Sleeves 1-1/8" and larger require swaging in the 1st stage dies and completing the swage in 2nd stage dies in a National Hydraulic Swaging Machine.**

## 1st STAGE

Step 1. Slide Sleeve over rope. Assemble Flemish Eye. See page 28 for assembly instructions.



Step 2. Slide sleeve fully over ends of wire rope.



Step 3. Lubricate both die cavities and lower die face. See page 24 for proper die selection.



Step 4. 1st pass – allow dies to remain open approximately 1/2 the distance from the time initial contact is made between sleeve and dies. Rotate fitting 45 to 90 degrees.



Step 5. 2nd pass – allow dies to remain open approximately 1/2 the distance from the time initial contact is made between sleeve and dies. Rotate fitting 45 to 90 degrees.



Step 6. 3rd pass – allow dies to remain open approximately 1/2 the distance from the time initial contact is made between sleeve and dies. Rotate fitting 45 to 90 degrees.



Step 7. 4th pass – allow dies to remain open approximately 1/2 the distance from the time initial contact is made between sleeve and dies. Rotate fitting 45 to 90 degrees.



Step 8. 5th and 6th pass – If sharp flashing does not occur, close die. Open dies and rotate fitting 45 to 90 degrees between passes.



# Flemish Type Wire Rope Sling Eyes – 2" & Larger

**2nd Stage** – Lubricate both die cavities and bottom die face. **See page 24 for die selection.**

Step 9. 1st pass – allow dies to remain open approximately  $\frac{1}{2}$  the distance from the time initial contact is made between the sleeve and dies. Rotate fitting 45 to 90 degrees.



Step 10. 2nd pass – allow dies to remain open approximately  $\frac{1}{2}$  the distance from the time initial contact is made between the sleeve and dies. Rotate fitting 45 to 90 degrees.

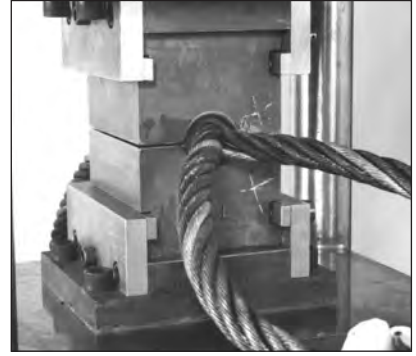

Step 11. 3rd pass – allow dies to remain open approximately  $\frac{1}{2}$  the distance from the time initial contact is made between the sleeve and dies. Rotate fitting 45 to 90 degrees.

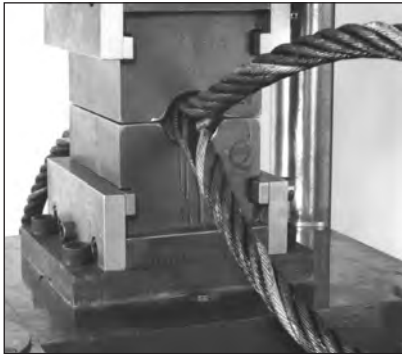

Step 12. 4th pass – allow dies to remain open approximately  $\frac{1}{2}$  the distance from the time initial contact is made between the sleeve and dies. Rotate fitting 45 to 90 degrees.

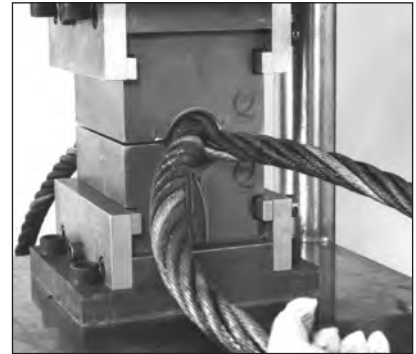

Step 13. 5th pass – allow dies to remain open approximately  $\frac{1}{2}$  the distance from the time initial contact is made between the sleeve and dies. Rotate fitting 45 to 90 degrees.



Step 14. 6th pass – allow dies to remain open approximately  $\frac{1}{2}$  the distance from the time initial contact is made between the sleeve and dies. Rotate fitting 45 to 90 degrees.



Step 15. 7th pass – If sharp flashing does not occur, close dies. Rotate fitting 45 to 90 degrees.



Step 16. 8th and 9th pass – Close dies to round fitting. Open dies and rotate fitting 45 to 90 degrees between passes. **Open die and check for proper after swage dimensions.** (See page 17 for proper use of No-Go Gauges).



Additional swaging may be required to provide smooth finish and achieve proper after swage dimensions.  
**Dies must be fully closed in 2nd stage die before swaging is complete.**

# QUIC-PASS® Swaging Procedures for Flemish Eye Terminations

## QUIC-PASS® Swaging Procedures

### Flemish Eye Terminations for 1/4" thru 1-1/2" S-505 Sleeves using the QUIC-PASS® Swaging System

QUIC-PASS® dies for National S-505 Standard Steel Sleeves 1/4" thru 1-1/2" are provided with one cavity. National S-505 1/4" thru 1-1/2" sleeves are designed to be swaged in either National standard dies or National QUIC-PASS® dies.

The QUIC-PASS® Swaging System for a National 500 Ton Swaging Machine includes the QUIC-PASS® dies, QUIC-PASS® die holders, a special guide post system and QUIC-PASS® No-Go Gauges. The QUIC-PASS® die holder will also work with National 5 x 7 standard swaging dies. The special guide post system is not required on National Swaging machines larger than 500 Tons. QUIC-PASS® dies for other makes of swaging machines are available (QUIC-PASS® Swaging procedures for other makes of swaging machines are the same as shown below). Die lubrication is critical for the optimum life of the Quic-Pass dies. Lubrication must be applied to the sleeve or die and maintained on the contacting surfaces for each pass during the swage process. The recommended lubrication contains special EP lubricity additives, and is used for extreme drawing operations. Approved lubrication: Shell Fenella Fluid D 2628 at full concentration, or equivalent. Per TDS REF Instructions Doc No. 040629.

## Use only National S-505 Standard Steel Sleeves

National S-505 Standard Steel Sleeves, when used with the QUIC-PASS® Swaging System, are only recommended for use with one (1) part 6 X 19 or 6 X 36, IPS or XIP (EIP), XXIP (EEIP), RRL, IWRC wire rope.

Before using any National Swage QUIC-PASS® Swaging System with any other type lay, construction, or grade of wire rope, it is recommended that the termination be destructive tested and documented to prove the adequacy of the assembly to be manufactured.

Step 1. Slide S-505 Standard Steel Sleeve over the wire rope.



Step 3. Slide S-505 sleeve fully over ends of wire rope to total sleeve depth.



Step 5. 1st pass – Place sling eye in the vertical plane, and close dies completely. Open dies and rotate fitting one flat (60°).



**Oozing of the oil from between the die faces will indicate when dies are fully closed.**

Step 7. Open dies and check for proper after swage dimensions.

Use a National QUIC-PASS® No-Go Gauge to check the after swage dimensions to ensure that it has been swaged to the proper dimension. When swaged properly, the gauge will slide up and down the full length of the sleeve on all three sets of opposing flats. See page 18 for proper use of No-Go Gauges.

Step 2. Construct Flemish Eye. See page 28 for assembly instructions.



Step 4. Oil lubricate both cavities (top and bottom) and lower die face as well as the sleeve. See page 24 for proper die selection.



**Oil lubrication is critical in order to obtain proper after swage dimensions and performance.**

Step 6. 2nd pass – Close dies completely.



**Dies must be fully closed in both passes before swaging is complete.**

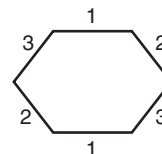

**Note: Use only No-Go Gauges designed for QUIC-PASS® systems.**

# Swage Fittings - Sockets

## Swaging Methods for S-501 and S-502

National S-501 and S-502 Carbon Steel Swage Sockets are designed for swaging in National dies. These swage fittings are designed to be used on one (1) part of 6 X 19 or 6 X 37, IPS or XIP (EIP), RRL, FC, or IWRC wire rope. These products are designed to be used with inch size wire rope.

**Before using any National Swage fitting with any other type lay, construction or grade of wire rope, it is recommended that the termination be destructive tested and documented to prove the adequacy of the assembly to be manufactured.**

## Cold Swaging Process

Cold swaging is a process which causes considerable movement and work hardening of the steel in the fitting. Exerting extreme pressures, the swaging machine forces the steel to flow into the crevices between the wires and strands of the wire rope. At the same time, the swaging machine forces the material to flow plastically along the length of the wire rope. These are a few of the reasons swaging is done in multiple passes in a well lubricated die.

## Protecting Dies and Swaging Machine

When the die lands touch each other, effective swaging stops. Additional swaging adds needless wear and strain on the dies and swaging machine. We recommend placing oil on the die faces and cavities. When swaging, the oozing of the oil from the die faces will indicate when the dies are closed. At this point, stop swaging.

## Avoid Excess Flashing

Flashing occurs when socket material flows out into the area between the die faces. Once formed, additional passes will not eliminate flashing. They will only fold back the flash and develop a permanent mark in the material and possibly create a crack.

**To avoid excess flashing, do the following:**

- Select proper die.
- Make sure that dies are in good condition and properly lubricated.
- Apply lubricant such as a light hydraulic oil to both die cavities and the lower die face.
- Follow swaging instructions on pages 39-41.

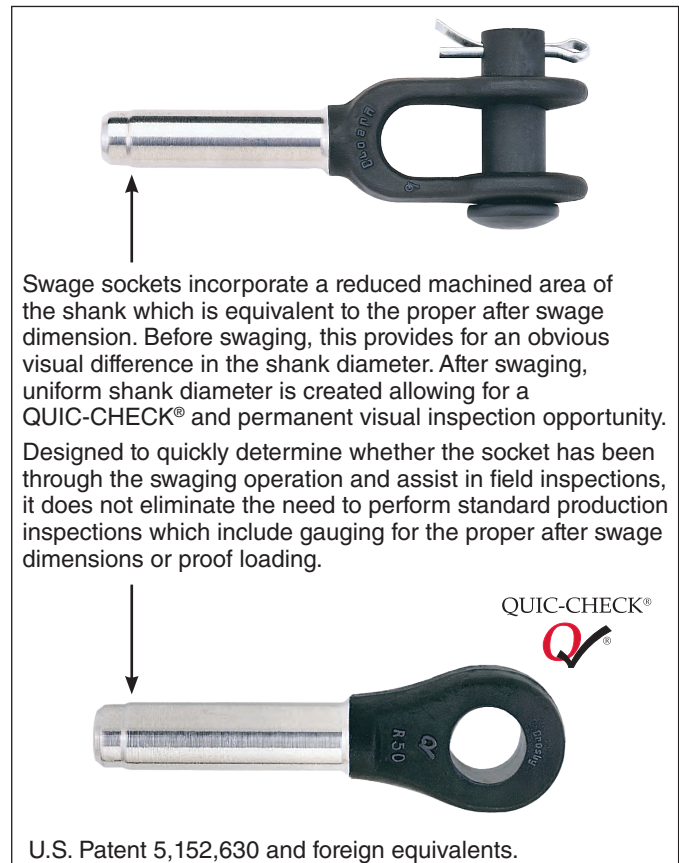
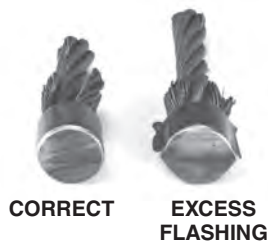

Swage sockets incorporate a reduced machined area of the shank which is equivalent to the proper after swage dimension. Before swaging, this provides for an obvious visual difference in the shank diameter. After swaging, uniform shank diameter is created allowing for a QUIC-CHECK® and permanent visual inspection opportunity. Designed to quickly determine whether the socket has been through the swaging operation and assist in field inspections, it does not eliminate the need to perform standard production inspections which include gauging for the proper after swage dimensions or proof loading.

## Identification Stamping

For Identification purposes, National Swage products can be impression stamped after swaging. Properly done, there should be no concern for fractures initiating from such impressions.

**To stamp S-501 and S-502 sockets:**

- Use round corner or low stress stamps. Stamp to maximum depth of 0.015 in. (1/64").
- Stamp in the area on the side of the socket head, as shown in the illustration.



**NOTE: DO NOT STAMP ON SWAGING SHANK.**

# National Open Swage Sockets



S-501



- Forged from special bar quality carbon steel, suitable for cold forming.
- Swage socket terminations have an efficiency rating of 100% based on the catalog strength of wire rope.
- Hardness controlled by spheroidize annealing.
- Stamp for identification after swaging without concern for fractures. (See page 36)
- Swage sockets incorporate a reduced machined area of the shank which is equivalent to the proper "After Swage" dimension. Before swaging, this provides for an obvious visual difference in the shank diameter. After swaging, a uniform shank diameter is created allowing for a QUIC-CHECK® and permanent visual inspection opportunity.
- Designed to quickly determine whether the socket has been through the swaging operation and assist in field inspections, it does not eliminate the need to perform standard production inspections which include gauging for the proper "After Swage" dimensions or proof loading.
- U.S. Patent 5,152,630 and foreign equivalents.

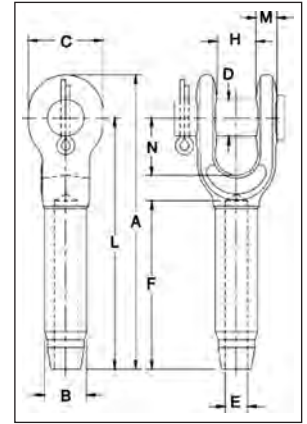

NOTE: S-501 Swage Sockets are recommended for use with 6 x 19 or 6 x 37, IPS or XIP (EIP), XXIP (EEIP), RRL, FC or IWRC wire rope.

Before using any National Swage fitting with any other type lay, construction or grade of wire rope, it is recommended that the termination be destructive tested and documented to prove the adequacy of the assembly to be manufactured.

In accordance with ASME B30.9, all slings terminated with swage sockets shall be proof loaded.\*

## S-501 Open Swage Sockets

Rope Size*		S-501 Stock No.		Wt. Each (lbs.)	Before Swage Dimensions (in.)											Max. After Swage Dim. (in.)	Swager / Die Data			
					A	B	C	D	E	F	H	L	M	N	Stock No.		Side Load			
(in.)	(mm)		**													Die Description	500 Ton 5 x 7	1500 Ton 6 x 12	1500 Ton 6 x 12	3000 Ton 6 x 12
1/4	6	1039021	1054001	.52	4.78	.50	1.38	.69	.27	2.19	.69	4.00	.38	1.47	.46	1/4 Socket	1192845	-	-	-
5/16	8	1039049	1054010	1.12	6.30	.78	1.62	.81	.34	3.25	.80	5.34	.48	1.67	.71	5/16-3/8 Socket	1192863	-	-	-
3/8	9-10	1039067	1054029	1.30	6.30	.78	1.62	.81	.41	3.25	.80	5.34	.48	1.67	.71	5/16-3/8 Socket	1192863	-	-	-
7/16	11-12	1039085	1054038	2.08	7.82	1.01	2.00	1.00	.49	4.31	1.00	6.69	.56	1.96	.91	7/16-1/2 Socket	1192881	-	-	-
1/2	13	1039101	1054047	2.08	7.82	1.01	2.00	1.00	.55	4.31	1.00	6.69	.56	1.96	.91	7/16-1/2 Socket	1192881	-	-	-
9/16	14	1039129	1054056	4.67	9.54	1.27	2.38	1.19	.61	5.38	1.25	8.13	.68	2.21	1.16	9/16-5/8 Socket	1192907	-	-	-
5/8	16	1039147	1054065	4.51	9.54	1.27	2.38	1.19	.68	5.38	1.25	8.13	.68	2.21	1.16	9/16-5/8 Socket	1192907	-	-	-
3/4	18-20	1039165	1054074	7.97	11.61	1.56	2.75	1.38	.80	6.44	1.50	10.00	.78	2.69	1.42	3/4 Socket	1192925	-	-	-
7/8	22	1039183	1054083	11.52	13.37	1.72	3.13	1.63	.94	7.50	1.75	11.63	.94	3.20	1.55	7/8 Socket	1192943	-	-	-
1	24-26	1039209	1054092	17.80	15.47	2.00	3.69	2.00	1.07	8.63	2.00	13.38	1.07	3.68	1.80	1 Socket	1192961	-	-	-
1-1/8	28	1039227	1054104	25.25	17.35	2.25	4.06	2.25	1.19	9.75	2.25	15.00	1.19	4.18	2.05	1-1/8 Socket	1192989	-	-	-
1-1/4	32	1039245	1054113	35.56	19.20	2.53	4.50	2.50	1.34	10.81	2.50	16.50	1.27	4.64	2.30	1-1/4 Socket	1193005	-	-	-
1-3/8	34-36	1039263	1054122	43.75	21.10	2.81	5.25	2.50	1.46	11.88	2.41	18.13	1.46	5.25	2.56	1-3/8 Socket	1193023	-	-	-
1-1/2	38-40	1039281	1054131	58.50	23.17	3.08	5.50	2.75	1.59	12.81	3.00	19.75	1.65	5.70	2.81	1-1/2 Socket	1193041	1191267	1195355	1195192
1-3/4	44	1039307	1054140	88.75	26.70	3.40	6.25	3.50	1.87	15.06	3.50	23.00	2.07	6.67	3.06	1-3/4 Socket	1193069	1191276	1195367	1195209
2	48-52	1042767	1054159	146.2	31.15	3.94	7.80	3.75	2.12	17.06	4.00	26.75	1.81	8.19	3.56	2 Socket	1193087	1191294	1195379	1195218

\* Maximum Proof Load shall not exceed 50% of XXIP rope catalog breaking strength.

\*\* Assembly with bolt, nut and cotter pin.

# National Closed Swage Sockets



S-502



- Forged from special bar quality carbon steel, suitable for cold forming.
- Swage socket terminations have an efficiency rating of 100% based on the catalog strength of wire rope.
- Hardness controlled by spheroidize annealing.
- Stamp for identification after swaging without concern for fractures. (See page 36)
- Swage sockets incorporate a reduced machined area of the shank which is equivalent to the proper "After Swage" dimension. Before swaging, this provides for an obvious visual difference in the shank diameter. After swaging, a uniform shank diameter is created allowing for a QUIC-CHECK® and permanent visual inspection opportunity.
- Designed to quickly determine whether the socket has been through the swaging operation and assist in field inspections, it does not eliminate the need to perform standard production inspections which include gauging for the proper "After Swage" dimensions or proof loading.
- U.S. Patent 5,152,630 and foreign equivalents.

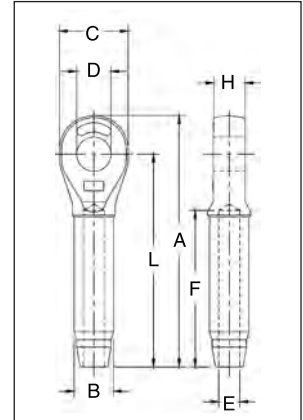

NOTE: S-502 Swage Sockets are recommended for use with 6 x 19 or 6 x 36, IPS or XIP (EIP), XXIP (EEIP), RRL, FC or IWRC wire rope.

Before using any National Swage fitting with any other type lay, construction or grade of wire rope, it is recommended that the termination be destructive tested and documented to prove the adequacy of the assembly to be manufactured.

In accordance with ASME B30.9, all slings terminated with swage sockets shall be proof loaded.\*

## S-502 Closed Swage Sockets

S-502 Closed Swage Socket Specifications												Swage / Die Data					
S-502 Stock No.	Rope Size*		Wt. Each (lbs.)	Before Swage Dimensions (in.)								Max. After Swage Dim. (in.)	Stock No.		Side Load		
	(in.)	(mm)		A	B	C	D	E	F	H	L		Die Description	500 1000 1500 Ton 5 x 7	1500 3000 Ton 6 x 12	1500 Ton 6 x 12	3000 Ton 6 x 12
1039325	1/4	6	.33	4.28	.50	1.38	.76	.27	2.19	.50	3.50	.46	1/4 Socket	1192845	-	-	-
1039343	5/16	8	.75	5.42	.77	1.62	.88	.34	3.25	.68	4.50	.71	5/16-3/8 Socket	1192863	-	-	-
1039361	3/8	9-10	.72	5.42	.78	1.62	.88	.41	3.25	.68	4.50	.71	5/16-3/8 Socket	1192863	-	-	-
1039389	7/16	11-12	1.42	6.88	1.01	2.00	1.07	.49	4.31	.87	5.75	.91	7/16-1/2 Socket	1192881	-	-	-
1039405	1/2	13	1.42	6.88	1.01	2.00	1.07	.55	4.31	.87	5.75	.91	7/16-1/2 Socket	1192881	-	-	-
1039423	9/16	14	2.92	8.59	1.27	2.38	1.28	.61	5.38	1.14	7.25	1.16	9/16-5/8 Socket	1192907	-	-	-
1039441	5/8	16	2.85	8.59	1.27	2.38	1.28	.68	5.38	1.14	7.25	1.16	9/16-5/8 Socket	1192907	-	-	-
1039469	3/4	18-20	5.00	10.25	1.56	2.88	1.49	.80	6.44	1.33	8.63	1.42	3/4 Socket	1192925	-	-	-
1039487	7/8	22	6.80	11.87	1.72	3.12	1.73	.94	7.50	1.53	10.09	1.55	7/8 Socket	1192943	-	-	-
1039502	1	24-26	10.40	13.56	2.00	3.62	2.11	1.07	8.63	1.78	11.50	1.80	1 Socket	1192961	-	-	-
1039520	1-1/8	28	14.82	15.03	2.25	4.00	2.37	1.19	9.75	2.03	12.75	2.05	1-1/8 Socket	1192989	-	-	-
1039548	1-1/4	32	21.57	16.94	2.53	4.50	2.62	1.34	10.81	2.25	14.38	2.30	1-1/4 Socket	1193005	-	-	-
1039566	1-3/8	34-36	28.54	18.59	2.81	5.00	2.62	1.46	11.88	2.29	15.75	2.56	1-3/8 Socket	1193023	-	-	-
1039584	1-1/2	38-40	38.06	20.13	3.08	5.38	2.87	1.59	12.81	2.56	17.00	2.81	1-1/2 Socket	1193041	1191267	1195355	1195192
1039600	1-3/4	44	51.00	23.56	3.40	6.25	3.63	1.87	15.06	3.08	20.00	3.06	1-3/4 Socket	1193069	1191276	1195367	1195209
1042589	2	48-52	89.25	27.13	3.94	7.25	3.88	2.12	17.06	3.31	23.00	3.56	2 Socket	1193087	1191294	1195379	1195218

\* Maximum Proof Load shall not exceed 50% of XXIP rope catalog breaking strength.

# Swage Socket Terminations – 1/4" - 1"

S-501 and S-502 Swage Sockets 1/4" through 1" (See page 40-41 for larger sizes).

S-501 and S-502 Swage Sockets are swaged in specially designed National Swage dies with a relief and extra length. **Small size sockets, through 1" should be swaged full shank.** To swage the socket, use the following procedure.

Step 1: For proper insertion, mark rope using Column F Dimension on page 37-38.



Step 2: Slide rope into socket until it is fully inserted in the shank. Inspect mark for full insertion.



Step 3: Lubricate both die cavities and lower die face. See pages 37 and 38 for proper die selection.



Step 4: 1st pass – allow dies to remain open approximately 1/2 the distance from time initial contact is made between socket and dies. Rotate fitting 45 to 90 degrees.

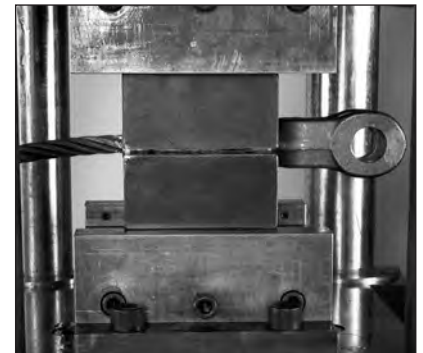

Step 5: 2nd pass – allow dies to remain open approximately 1/2 the distance from time initial contact is made between socket and dies. Rotate fitting 45 to 90 degrees.



Step 6: 3rd pass – If sharp flashing does not occur, close dies and rotate fitting 45 to 90 degrees.



Step 7: 4th and 5th pass – Close dies to round fitting. Open dies and rotate 45 to 90 degrees between passes. **Open dies and check termination for proper after swage dimensions.** (See page 17 for proper use of No-Go Gauges).

QUIC-CHECK®

Additional swaging may be required to provide smooth finish and achieve proper after swage dimensions. **Dies must be fully closed before swaging is complete.**

# Swage Socket Terminations – 1 1/8" & Larger

S-501 and S-502 Swage Sockets 1-1/8" and larger (See page 39 for smaller sizes).

S-501 and S-502 swage sockets are swaged in specially designed National Swage socket dies with a relief and extra length. **Sockets 1-1/8" and larger should be swaged full shank.** To swage the socket, use the following procedure.

Step 1: For proper insertion, mark rope using Column F Dimension on page 37 or 38.



Step 2: Slide rope into socket until it is fully inserted in the shank. Inspect mark for full insertion.



Step 3: Lubricate both die cavities and lower die face. See pages 37 and 38 for proper die selection.



Step 4: 1st pass – allow dies to remain open approximately 1/2 the distance from time initial contact is made between socket and dies. Rotate fitting 45 to 90 degrees.

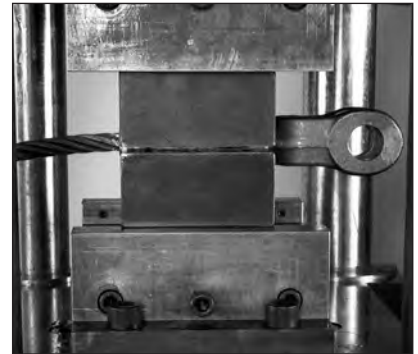

Step 5: 2nd pass – allow dies to remain open approximately 1/2 the distance from time initial contact is made between socket and dies. Rotate fitting 45 to 90 degrees.



Step 6: 3rd pass – If sharp flashing does not occur, close dies. Open dies and rotate fitting 45 to 90 degrees.

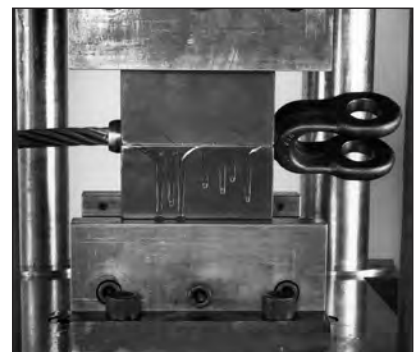

Step 7: 4th pass – Close dies to round fitting. **Open dies and check for proper after swage dimensions.** (See page 17 for proper use of No-Go Gauges).

Note: Limited swaging capacity may require the use of progressive swaging (See page 41).

QUIC-CHECK®



Additional swaging may be required to provide smooth finish and achieve proper after swage dimensions. **Dies must be fully closed before swaging is complete.**

# Swage Socket Terminations – Progressive Swaging

S-501 and S-502 swage sockets, and other fittings, must be swaged progressively if one of the following conditions exist.

1. The die Working Load Limit (WLL) is lower than the required swaging tonnage. **Warning – you must adjust tonnage so maximum die Working Load Limit is not exceeded. Failure to do this can result in serious injury or death.**
2. The Swaging Machine Capacity is lower than the required tonnage to swage the socket full shank.

Before swaging make sure you follow all instructions in this manual.

**NOTE: For additional information, see Swaging Machine Capacity Chart on page 12.**

Step 1. Lubricate both die cavities and lower die face. See pages 37 and 38 for proper die selection.



Step 2. Insert tapered end, or rope end of socket, about one third (1/3) of the shank into the proper die. Close the die until it comes in contact with the shank, and continue closing dies to approximately one-half (1/2) the distance between the dies.



Step 3. Open dies and lubricate the socket shank. Rotate the socket shank 45 to 90 degrees and repeat closing the die to about one-half (1/2) the distance from the previous pass.

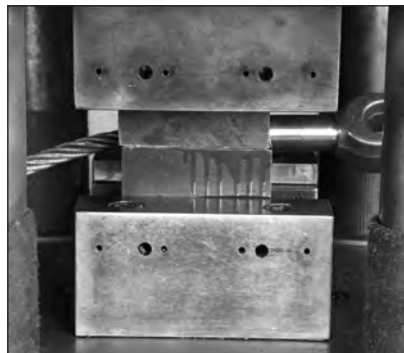

Step 4. Open dies and lubricate the socket shank. Rotate the socket shank 45 to 90 degrees and close the die.



Step 5. Open dies and insert the next one-third (1/3) into the die and repeat the process. This should be done until the full shank is swaged. Additional passes may be required to round out the shank and insure the correct after swage dimensions are met.

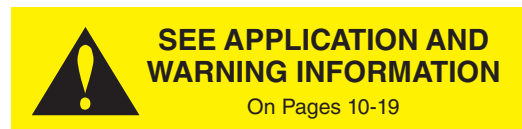

**Failure to reduce Swaging Machine tonnage to Working Load Limit (WLL) of die can cause serious injury or death. For instructions on adjusting tonnage see Die Working Load Limit Pressure Adjustment section of Swaging Machine Application Instructions (See Page 12).**

# COLD TUFF® Swage Fittings – Buttons

## Swaging Methods for S-409 Buttons

National S-409 Steel Buttons are designed for use with swaging in National dies. These swage fittings are designed to be used on one (1) part of 6 X 19 or 6 X 37 FC IPS or IWRC EIPS Right Regular Lay wire rope.

**Before using any National Swage fitting with any other type lay, construction or grade of wire rope, it is recommended that the termination be destructive tested and documented to prove the adequacy of the assembly to be manufactured.**

## Cold Swaging Process

Cold swaging is a process which causes considerable movement and work hardening of the steel in the fitting. Exerting extreme pressures, the swaging machine forces the steel to flow into the crevices between the wires and strands of the wire rope. At the same time, the swaging machine forces the material to flow plastically along the length of the wire rope. These are a few of the reasons swaging is done on steel fittings in multiple passes in a well lubricated die.

## Protecting Dies and Swaging Machines

When the die lands touch each other, effective swaging stops. Additional swaging adds needless wear and strain on the dies and swaging machine. We recommend placing oil on the die faces and cavities. When swaging, the oozing of the oil from the die faces will indicate when the dies are closed. At this point, stop swaging.

## Avoid Excess Flashing

Flashing occurs when sleeve material flows out into the area between the die faces. Once formed, additional passes will not eliminate flashing. They will only fold back the flash and develop a permanent mark in the material and possibly create a crack.

### To avoid excess flashing, do the following:

- Select proper dies.
- Make sure that dies are in good condition and properly lubricated.
- Apply lubricant such as a light hydraulic oil to both die cavities and the lower die face.
- Follow swaging instructions on pages 44-45.



## Identification Stamping

For identification purposes, COLD TUFF® swage products can be impression stamped after swaging. Properly done, there should be no concern for fractures initiating from such impressions.

### To stamp National S-409 Buttons

- Use round corner or low stress stamps. Stamp to maximum depth of 0.015 in. (1/64”).
- Stamp in the area on the side of the button, in the plane of the rope, no less than 0.250 in. (1/4”) from either end of the sleeve.



# National Swage Buttons

## S-409



- Swage Button terminations have an efficiency rating of 98% based on the catalog strength of wire rope.
- Special processed, low carbon steel.
- COLD TUFF® for better swageability.
- Stamp for identification after swaging without concern for fractures. (See page 42)

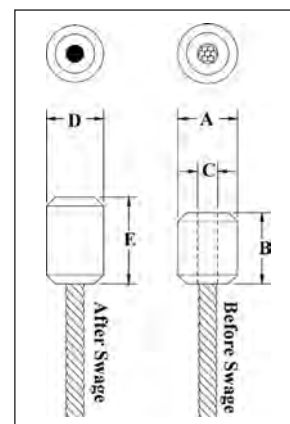

NOTE: S-409 Buttons are recommended for use with 6 x 19 or 6 x 37, IPS or XIP (EIP), RRL, FC or IWRC wire rope.

Before using any National Swage fitting with any other type lay, construction or grade of wire rope, it is recommended that the termination be destructive tested and documented to prove the adequacy of the assembly to be manufactured.

## S-409 COLD TUFF® Buttons

Size No.	Rope Size		S-409 Stock No.	Weight Per 100 Pcs. (lbs.)	Before Swage Dimensions (in.)			After Swage Dimensions (in.)		Swager / Die Data	
	(in.)	(mm)			A	B	C	D Maximum After Swage Dimensions	E Length*	Die Description	Stock No. 500 Tons 1000 Tons 1500 Tons 5 x 7
1 SB	1/8	3	1040171	2	.42	.50	.14	.40	.61	1/8 - 1/4 Button	1191621
3 SB	3/16	5	1040215	4	.56	.70	.20	.52	.84	1/4 1st Stage	1197528
5 SB	1/4	6-7	1040251	8	.68	1.06	.31	.58	1.41	1/8 - 1/4 Button	1191621
7 SB	5/16	8	1040297	16	.88	1.13	.36	.77	1.33	3/8 1st Stage	1192364
8 SB	3/8	9-10	1040313	15	.88	1.48	.42	.77	1.69	3/8 1st stage	1192364
9 SB	7/16	11	1040331	30	1.13	1.63	.48	1.03	1.94	1/2 1st Stage	1192408
10 SB	1/2	13	1040359	50	1.31	1.89	.55	1.16	2.17	5/8 Socket	1192907
11 SB	9/16	14	1040377	70	1.44	2.02	.61	1.29	2.41	9/16 -5/8 Button	1191665
12 SB	5/8	16	1040395	100	1.56	2.42	.67	1.42	2.89	3/4 Socket	1192925
13 SB	3/4	18-20	1040411	131	1.68	2.74	.80	1.55	3.25	3/4 1st Stage	1192462
14 SB	7/8	22	1040439	220	2.00	3.27	.94	1.80	3.86	7/8 1st Stage	1192480
15 SB	1	25-26	1040457	310	2.25	3.67	1.06	2.05	4.36	1 1st Stage	1192505
16 SB	1-1/8	28-29	1040475	450	2.56	4.05	1.19	2.30	4.81	1-1/8 1st Stage	1192523
17 SB	1-1/4	31-32	1040493	650	2.81	4.57	1.33	2.56	5.42	1-3/8 Socket	1193023

\* NOTE: Length is measured from outside end of termination.

# Button Terminations – 1/8" - 7/8"

S-409 Button Terminations 1/8" (#1) through 7/8" (#14) (See page 45 for larger sizes).

Buttons are swaged in open channel dies. Refer to the chart on page 43 for proper die selection.

To swage the button, use the following procedure:

Step 1: Slide wire rope through button until the end of the wire rope protrudes a minimum of 1/8" (3mm) rope diameter from the end of the button. After swaging, the rope should be about flush with the button end.



Step 2: Lubricate both die cavities and lower die face. (See page 43 for proper die selection).



Step 3: 1st pass – allow dies to remain open approximately 1/2 the distance from the time initial contact is made between the button and dies. Open dies and rotate fitting 45 to 90 degrees.



Step 4: 2nd and 3rd passes – allow dies to remain open approximately 1/2 the distance from the time initial contact is made between the button and dies. Open dies and rotate fitting 45 to 90 degrees between passes.

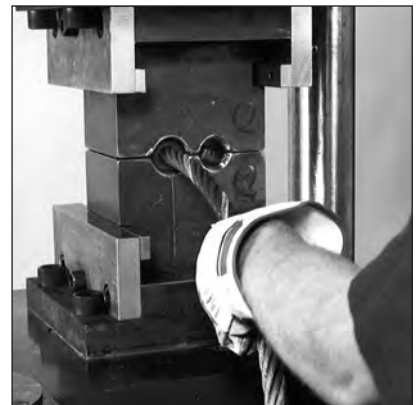

Step 5: 4th pass – if sharp flashing does not occur, close dies. Open dies and rotate fitting 45 to 90 degrees.

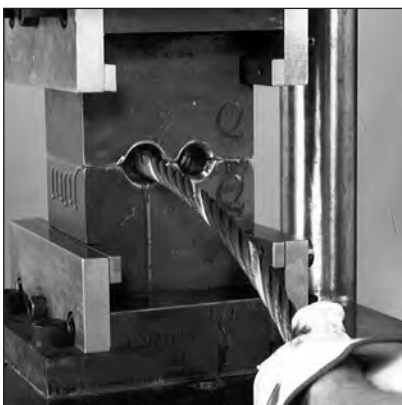

Step 6: 5th and 6th passes – Rotate fitting 45 degrees (1/8 turn). Close dies to round fitting. Open dies and rotate fitting 45 to 90 degrees between passes. **Open dies and check termination for proper after swage dimensions.** (See page 17 for proper use of No-Go Gauges).



Additional swaging may be required to provide smooth finish and achieve proper after swage dimensions.

**Dies must be fully closed before swaging is complete.**

# Button Terminations – 1" & Larger

S-409 Button Terminations 1" (#15) through 1-1/4" (#17) (See page 44 for smaller sizes).

Buttons are swaged in open channel dies. Refer to chart on page 43 for proper die selection.

To swage the button, use the following procedure:

Step 1: Slide wire rope through button until the end of the wire rope protrudes a minimum of 1/8" (3mm) from the end of the button. After swaging, the rope should be about flush with the button end.



Step 2: Lubricate both cavities and lower die face. See page 43 for proper die selection.



Step 3: 1st pass – allow dies to remain open approximately 1/2 the distance from the time initial contact is made between the button and dies. Open dies and rotate fitting 45 to 90 degrees.



Step 4: 2nd, 3rd and 4th passes – allow dies to remain open approximately 1/2 the distance from the time initial contact is made between the button and dies. Open dies and rotate fitting 45 to 90 degrees.

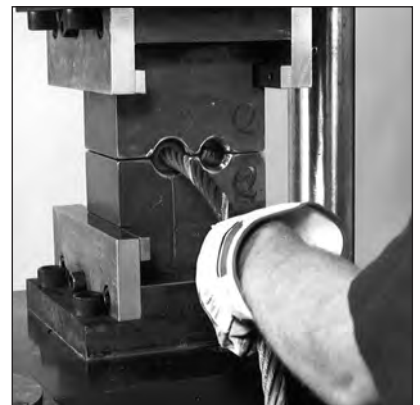

Step 5: 5th pass – if sharp flashing does not occur, close dies. Open dies and rotate fittings 45 to 90 degrees.

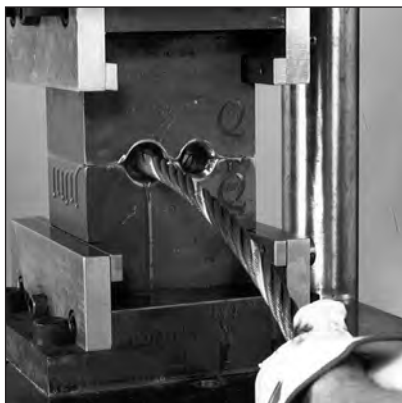

Step 6: 6th and 7th passes – Close dies to round fitting. Open dies and rotate fitting 45 to 90 degrees between passes. **Open dies and check termination for proper after swage dimensions.** (See page 17 for proper use of No-Go Gauge).



Additional swaging may be required to provide smooth finish and achieve proper after swage dimensions.  
**Dies must be fully closed before swaging is complete.**

# COLD TUFF® Swage Fittings – Duplex Sleeves

## Swaging Methods for National S-506 Turnback Eyes

National S-506 carbon steel sleeves are designed for use with turnback eye splices and for swaging in National dies.

These swage fittings are designed to be used on one (1) part of 6 X 19 or 6 X 37 FC IPS or IWRC EIPS Right Regular Lay wire rope.

**Before using any National Swage fitting with any other type lay, construction or grade of wire rope, it is recommended that the termination be destructive tested and documented to prove the adequacy of the assembly to be manufactured.**

## Cold Swaging Process

Cold swaging is a process which causes considerable movement and work hardening of the steel in the fitting. Exerting extreme pressures, the swaging machine forces the steel to flow into the crevices between the wires and strands of the wire rope. At the same time, the swaging machine forces the material to flow plastically along the length of the wire rope. These are a few of the reasons swaging is done on steel fittings in multiple passes in a well lubricated die.

## Protecting Dies and Swaging Machines

When the die lands touch each other, effective swaging stops. Additional swaging will add needless wear and strain on the dies and swaging machine. We recommend placing oil on the die faces and cavities. When swaging, the oozing of the oil from the die faces will indicate when the dies are closed. At this point, stop swaging.

## Avoid Excess Flashing

Flashing occurs when sleeve material flows out into the area between the die faces. Once formed, additional passes will not eliminate flashing. They will only fold back the flash and develop a permanent mark in the material and possibly create a crack.

**To avoid excess flashing, do the following:**

- Select proper dies.
- Make sure that dies are in good condition and properly lubricated.
- Apply lubricant such as a light hydraulic oil to both die cavities and the lower die face.
- Follow swaging instructions on pages 48-49.

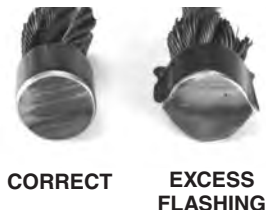

## Identification Stamping

For identification purposes, National COLD TUFF® swage products can be impression stamped after swaging. Properly done, there should be no concern for fractures initiating from such impressions.

**To stamp S-506 sleeves:**

- Use round corner or low stress stamps. Stamp to maximum depth of 0.015 in. (1/64”).
- Stamp in area on the side of the sleeve, in the plane of the sling eye, and no less than 0.250 in. (1/4”) from either end of the sleeve.



# National Swage Duplex Sleeves

## S-506



- For turnback wire rope splicing.
- Special processed low carbon steel.
- Turnback terminations have efficiency ratings of 94% based on the catalog strength of wire rope.
- Designed for lower temperature toughness.
- Resists cracking when swaged (equals or exceeds stainless steel sleeves).
- COLD TUFF® for better swageability.
- Stamp for identification after swaging without concern for fractures. (See page 46)

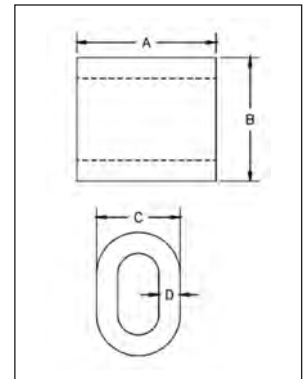

NOTE: S-506 Duplex sleeves are recommended for use with 6 x 19 or 6 x 37, IPS or XIP (EIP), RRL, FC or IWRC wire rope. Before using any National Swage fitting with any other type lay, construction or grade of wire rope, it is recommended that the termination be destructive tested and documented to prove the adequacy of the assembly to be manufactured.

## S-506 COLD TUFF® Duplex Non-Tapered Sleeves

Rope Size		S-506 Stock No.	Weight Per 100 Pcs. (lbs.)	Pkg. Qty.	Before Swage Dimensions (in.)				Max. After Swage Dimensions (in.)	Swager / Die Data	
(in.)	(mm)									Die Description	Stock No. 500 Tons 1000 Tons 1500 Tons 5 x 7
					A	B	C	D			
5/16	8	1039334	17	200	1.25	1.06	.81	.19	.77	3/8 1st Stage	1192364
3/8	9-10	1039352	13	100	1.25	1.12	.81	.14	.77	3/8 1st Stage	1192364
7/16	11	1039370	31	50	1.63	1.41	1.02	.19	1.03	1/2 1st Stage	1192408
1/2	13	1039398	27	50	1.63	1.44	1.02	.16	1.03	1/2 1st Stage	1192408
9/16	14	1039414	63	25	2.25	1.72	1.23	.23	1.29	5/8 1st Stage	1192444
5/8	16	1039432	54	25	2.25	1.84	1.28	.20	1.29	5/8 1st Stage	1192444
3/4	18-20	1039450	91	10	2.63	2.16	1.52	.23	1.55	3/4 1st Stage	1192462
7/8	22	1039478	126	10	2.88	2.50	1.75	.27	1.80	7/8 1st Stage	1192480
1	25-26	1039496	187	10	3.06	2.84	2.00	.33	2.05	1 1st Stage	1192505
1-1/4	30-32	1039539	384	Bulk	4.06	3.50	2.50	.38	2.56	1-3/8 Socket	1193023

# Turnback Terminations – 5/16" - 5/8"

Turnback Eye Terminations using 5/16" through 5/8" S-506 sleeves utilize the open cavity of the S-505 Standard Steel Sleeve die on a National Hydraulic Swaging Machine. (See page 49 for larger sizes.) Each S-505 Standard Steel Sleeve die contains 2 cavities (open and tapered).

To form the eye and swage the termination, use the following procedure:

Step 1: Slide the end of the rope through the sleeve and turn back the wire rope end through the S-506 Duplex Steel Sleeve and adjust the rope to form the proper eye size. Allow approximately 1 (one) rope diameter to extend past the end of the sleeve. This will provide for elongation of the fitting during swaging. **See page 47 for proper die selection.**



Step 2: Lubricate both die cavities and lower die face.

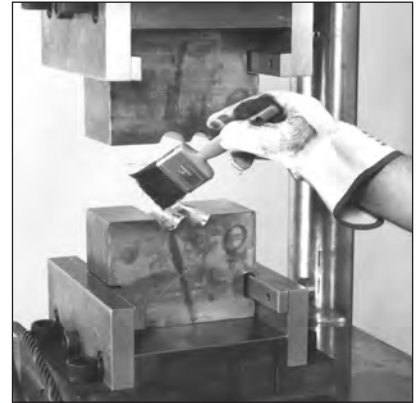

Step 3: 1st pass – allow dies to remain open approximately 1/2 the distance from time initial contact is made between sleeve and dies. Open dies and rotate fitting 45 to 90 degrees.

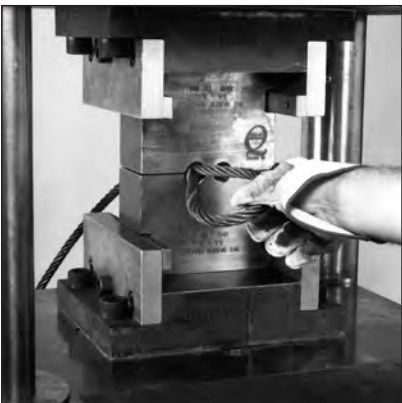

Step 4: 2nd pass – allow dies to remain open approximately 1/2 the distance from the time initial contact is made between the sleeve and dies. Open dies and rotate fitting 45 to 90 degrees.

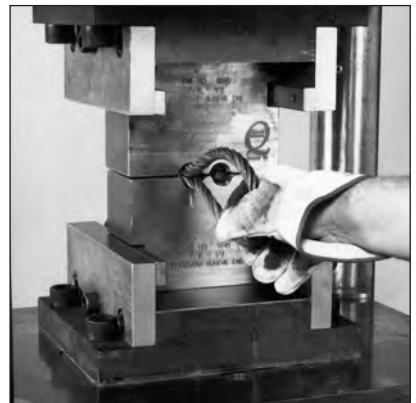

Step 5: 3rd pass – If sharp flashing does not occur, close dies. Open dies and rotate fitting 45 to 90 degrees.



Step 6: 4th and 5th pass – Close dies to round fitting. Open dies and rotate fitting 45 to 90 degrees between passes. **Open dies and check for proper after swage dimension.** (See page 17 for proper use of No-Go Gauge).



Additional swaging may be required to provide smooth finish and achieve proper after swage dimensions. **Dies must be fully closed before swaging is complete.**

# Turnback Terminations – 3/4" - 1 1/4"

Turnback eye terminations using 3/4" through 1" National S-506 Sleeve utilize open cavity of the S-505 Standard Steel Sleeve die on the National Hydraulic Swaging Machine. Each 3/4" through 1" S-505 Standard Steel Sleeve die contains 2 cavities (open and tapered). The 1-1/4" size S-506 sleeve utilizes the 1-3/8" socket (S-501 and S-502) die. (See page 48 for smaller sizes)

To form the eye and swage the termination, use the following procedure:

Step 1: Slide the end of the rope through the sleeve and turn back the wire rope end through the S-506 Duplex Steel Sleeve and adjust the rope to form proper eye size. Allow approximately 1 (one) rope diameter to extend past the end of the sleeve. This will provide for elongation of the fitting during swaging. **See page 47 for proper die selection.**



Step 2: Lubricate both die cavities and lower die face.

Step 3: 1st pass – allow dies to remain open approximately 1/2 the distance from the time initial contact is made between the sleeve and dies. Open dies and rotate fitting 45 to 90 degrees.

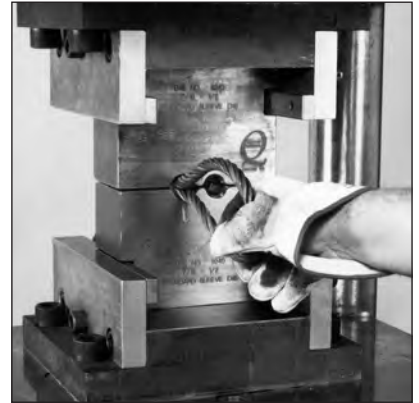

Step 4: 2nd pass – allow dies to remain open approximately 1/2 the distance from the time initial contact is made between the sleeve and dies. Open dies and rotate fitting 45 to 90 degrees.

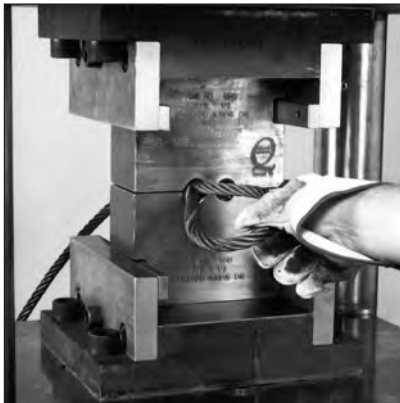

Step 5: 3rd pass – allow dies to remain open approximately 1/2 the distance from the time initial contact is made between the sleeve and dies. Open dies and rotate fitting 45 to 90 degrees.



Step 6: 4th pass – If sharp flashing does not occur, close dies. Open dies and rotate fitting 45 to 90 degrees.

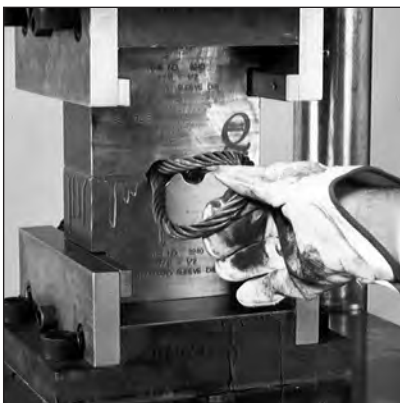

Step 7: 5th and 6th pass – Close dies to round fitting. Open dies and rotate 45 to 90 degrees between passes. **Open dies and check for proper after swage dimensions.** (See Page 17 for proper use of No-Go Gauges).



Additional swaging may be required to provide smooth finish and achieve proper after swage dimensions.  
**Dies must be fully closed before swaging is complete.**

# Swage Fittings – Hooks

## Swaging Methods for S-319SWG

National S-319SWG carbon steel shank hooks are designed for swaging in National dies. These swage fittings are designed to be used on one (1) part of 6 X 19 or 6 X 37 IPS or XIP (EIP), RRL, FC, or IWRC wire rope.

**Before using any National Swage fitting with any other type lay, construction or grade of wire rope, it is recommended that the termination be destructive tested and documented to prove the adequacy of the assembly to be manufactured.**

## Cold Swaging Process

Cold swaging is a process which causes considerable movement and work hardening of the steel in the fitting. Exerting extreme pressures, the swaging machine forces the steel to flow into the crevices between the wires and strands of the wire rope. At the same time, the swaging machine forces the material to flow plastically along the length of the wire rope. These are a few of the reasons swaging is done in multiple passes in a well lubricated die.

## Protecting Dies and Swaging Machine

When the die lands touch each other, effective swaging stops. Additional swaging adds needless wear and strain on the dies and swaging machine. We recommend placing oil on the die faces and cavities.

When swaging, the oozing of the oil from the die faces will indicate when the dies are closed. At this point, stop swaging.

## Avoid Excess Flashing

Flashing occurs when socket material flows out into the area between the die faces. Once formed, additional passes will not eliminate flashing. They will only fold back the flash and develop a permanent mark in the material and possibly create a crack.

**To avoid excess flashing, do the following:**

- Select proper die.
- Make sure that dies are in good condition and properly lubricated.
- Apply lubricant such as a light hydraulic oil to both die cavities and the lower die face.
- Follow swaging instructions on pages 54-55.

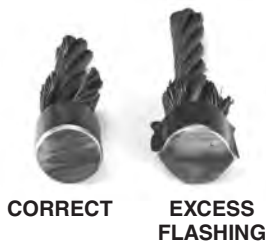

## S-319SWG



## Identification Stamping

For identification purposes, National swage products can be impression stamped after swaging. Properly done, there should be no concern for fractures initiating from such impressions.

**To stamp S-319SWG hooks:**

- Use round corner or low stress stamps. Stamp to maximum depth of 0.015 in. (1/64”).
- Stamp in the area on the side of the socket head, as shown in the illustration.



**NOTE: DO NOT STAMP ON SWAGING SHANK.**

# Shank Hooks for Swaging



**SEE APPLICATION AND WARNING INFORMATION**

Para Español: [www.thecrosbygroup.com](http://www.thecrosbygroup.com)

On Page 51 - 52

## S-319SWG



- Wide range of sizes available:
  - Working Load Limit: 0.4-14 Ton
  - Wire Rope sizes: 3/16" through 1-1/8"
- Swage shank hook terminations have an efficiency rating of 95% based on the catalog strength of wire rope.
- Quenched and Tempered. Heat treat process allows for ease of swaging.
- Forged Carbon Steel.
- Design Factor of 5 to 1.
- Black Oxide finish on body (Shank is uncoated).
- Utilizes standard Crosby 319N shank hooks with interlocking hook tip. Each hook has a pre-drilled cam which can be equipped with a latch.
- Utilizes standard National Swage swaging dies.
- All hooks incorporate Crosby's patented **QUIC-CHECK®** markings (Angle Indicators and Throat Deformation Indicators). See Crosby General Catalog for detailed information.

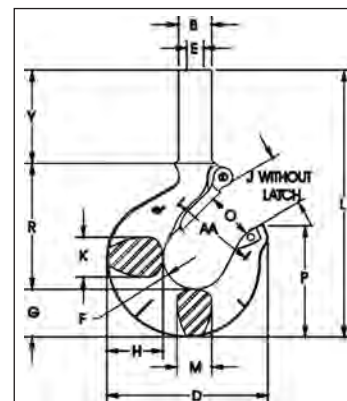

NOTE: For use with 6 X 19 or 6 X 36, IPS or XIP (EIP), XXIP (EEIP), RRL, FC, or IWRC wire rope.

Before using any Crosby fitting with any other type lay, construction or grade of wire rope, it is recommended that the termination be destructive tested and documented to prove the adequacy of the assembly to be manufactured. Refer to swage socket or swage button instructions in the Wire Rope End Terminations User's Manual for proper swaging techniques.

## S-319SWG Shank Hooks for Swaging

Wire Rope Size		S-319SWG Stock No.	Hook ID Code	Working Load Limit (Tons)*	Weight Each (lbs.)	Required Swaging Die		Maximum After Swage Diameter (in.)
(in.)	(mm)					Die Description	Die Stock No.	
3/16	5	1053002	DC	0.4	.55	1/8" Button	1191621	.40
1/4	6-7	1053011	FC	0.7	.77	1/4" Socket	1192845	.46
5/16	8	1053020	GC	1.1	1.26	1/4" Button	1191621	.58
5/16	8	1053039	HC	1.1	1.83	3/8" Socket	1192863	.71
3/8	9-10	1053048	HC	1.6	1.80	3/8" Socket	1192863	.71
7/16	11	1053057	IC	2.1	3.63	1/2" Socket	1192881	.91
1/2	12-13	1053066	IC	2.8	3.58	1/2" Socket	1192881	.91
9/16	14-15	1053075	JC	3.5	7.37	5/8" Socket	1192907	1.16
5/8	16	1053084	JC	4.3	7.30	5/8" Socket	1192907	1.16
3/4	18	1053093	KC	6.2	12.73	3/4" Socket	1192925	1.42
7/8	20-22	1053100	LC	8.3	17.58	7/8" Socket	1192949	1.55
1	24-26	1053119	NC	11.0	31.46	1" Socket	1192961	1.80
1-1/8	28-30		OC **	14.0	53.73	1-1/8" Socket	1192989	2.05

\* Minimum Ultimate Load is 5 times the Working Load Limit.

\*\* ID Code "O" is original 319 style hook.

Wire Rope Size		S-319SWG Stock No.	Dimensions (in.)														
(in.)	(mm)		B	D	E	F	G	H	J	K	L	M	O	P	R	Y	AA
3/16	5	1053002	.44	2.86	.20	.63	.73	.81	.93	.63	5.18	.63	.93	1.96	2.39	2.00	1.50
1/4	6-7	1053011	.50	3.15	.27	.69	.84	.94	.97	.71	5.72	.71	.97	2.22	2.63	2.25	2.00
5/16	8	1053020	.65	3.59	.34	.75	1.00	1.16	1.06	.88	6.39	.88	1.06	2.44	2.80	2.50	2.00
5/16	8	1053039	.77	3.99	.34	.81	1.14	1.31	1.19	.94	7.18	.94	1.16	2.78	3.21	2.75	2.00
3/8	9-10	1053048	.77	3.99	.41	.81	1.14	1.31	1.19	.94	7.18	.94	1.16	2.78	3.21	2.75	2.00
7/16	11	1053057	.98	4.84	.48	1.00	1.44	1.63	1.50	1.31	8.70	1.13	1.41	3.47	3.92	3.25	2.50
1/2	12-13	1053066	.98	4.84	.55	1.00	1.44	1.63	1.50	1.31	8.70	1.13	1.41	3.47	3.92	3.25	2.50
9/16	14-15	1053075	1.25	6.27	.61	1.25	1.82	2.06	1.78	1.66	10.51	1.44	1.69	4.59	4.86	3.75	3.00
5/8	16	1053084	1.25	6.27	.67	1.25	1.82	2.06	1.78	1.66	10.51	1.44	1.69	4.59	4.86	3.75	3.00
3/4	18	1053093	1.55	7.54	.80	1.50	2.26	2.63	2.41	1.88	12.63	1.63	2.22	5.25	6.00	4.25	4.00
7/8	20-22	1053100	1.70	8.33	.94	1.63	2.60	2.94	2.62	2.19	13.60	1.94	2.41	5.69	6.51	4.38	4.00
1	24-26	1053119	1.98	10.38	1.06	2.13	3.01	3.50	3.41	2.69	16.80	2.38	3.19	6.88	8.30	5.38	4.00
1-1/8	28-30	1053128	2.25	13.63	1.19	2.50	3.62	4.62	4.00	3.00	23.09	3.00	3.25	8.78	9.43	9.75	6.50

## CROSBY® SHANK HOOKS FOR SWAGING

### WARNINGS AND APPLICATION INSTRUCTIONS

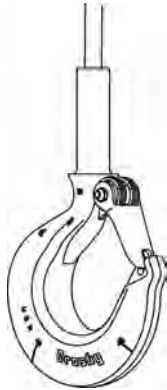

S-319SWG

- S-319SWG hooks are recommended for use with 6 x 19 or 6 x 36, IPS or XIP (EIP), XXIP (EEIP), RRL, FC or IWRC wire rope. Before using any National Swage fitting with any other type lay, construction of grade of wire rope, it is recommended that the termination be destructive tested and documented to prove the adequacy of the assembly to be manufactured.
- Use only Crosby shank hooks designed exclusively for swaging.
- A visual periodic inspection for cracks, nicks, wear gouges and deformation as part of a comprehensive documented inspection program, should be conducted by trained personnel in compliance with the schedule in ANSI B30.10.
- For hooks used in frequent load cycles or pulsating loads, the hook should be periodically inspected by Magnetic Particle or Dye Penetrant.
- Never use a hook whose throat opening has been increased, or whose tip has been bent more than 10 degrees out of plane from the hook body, or is in any other way distorted or bent.
- Note: A latch will not work properly on a hook with a bent or worn tip.
- Never use a hook that is worn beyond the limits shown in Figure 1.
- Remove from service any hook with a crack, nick, or gouge. Hooks with a nick or gouge shall be repaired by grinding lengthwise, following the contour of the hook, provided that the reduced dimension is within the limits shown in Figure 1. Contact Crosby Engineering to evaluate any crack.

### ⚠ WARNING

- Loads may disengage from hook if proper procedures are not followed.
- A falling load may cause serious injury or death.
- See OSHA Rule 1926.550(g) for personnel hoisting by cranes or derricks. A Crosby 319 hook with a PL Latch attached (when secured with bolt, nut and pin) may be used for lifting personnel. A Crosby S-319N hook with an S-4320 Latch attached (when secured with cotter pin or bolt, nut and pin) may be used for lifting personnel.
- Hook must always support the load. The load must never be supported by the latch.
- Never exceed the Working Load Limit (WLL) of the wire rope and hook system.
- Read and understand Wire Rope End Terminations User's Manual before swaging the hook.

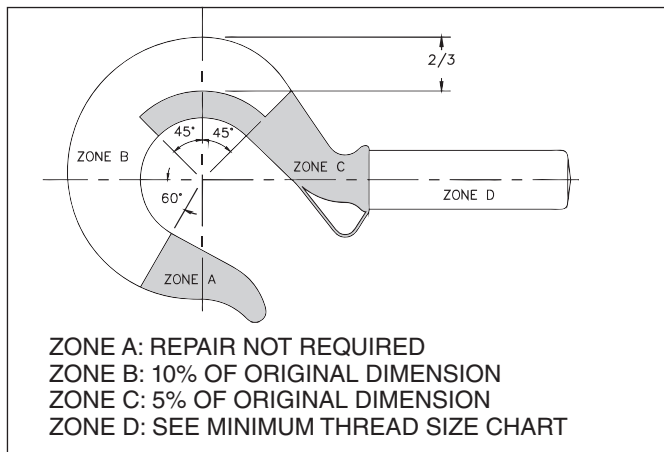

Figure 1

Never repair, alter, rework, or reshape a hook by welding, heating, burning, or bending.

- Never side load, back load, or tip load a hook. (See Figure 2).
- The use of a latch may be mandatory by regulations or safety codes; e.g., OSHA, MSHA, ANSI/ASME B30, insurance, etc. (Note: When using latches, see instructions in *Understanding: The Crosby Group Product Warnings* for further information.)
- Always make sure the hook supports the load (See Figure 3). The latch must never support the load (See Figure 4).
- When placing two (2) sling legs in hook, make sure the angle from the vertical to the outermost leg is not greater than 45 degrees, and the included angle between the legs does not exceed 90 degrees\* (See Figure 5).

\* For angles greater than 90 degrees, or more than two (2) legs, a master link or bolt type anchor shackle should be used to attach the legs of the sling to the hook.

- See ANSI/ASME B30.10 “Hooks” for additional information.
- In accordance with ANSI B30.9, all slings terminated by swaging shall be proof tested.
- S-319SWG hooks are designed to be a component of a system, and therefore rated based on the working limit of the system of which they are attached.
- The frame code on each S-319SWG hook is to facilitate proper latch selection only, and has no reference to the working load limit of the hook.

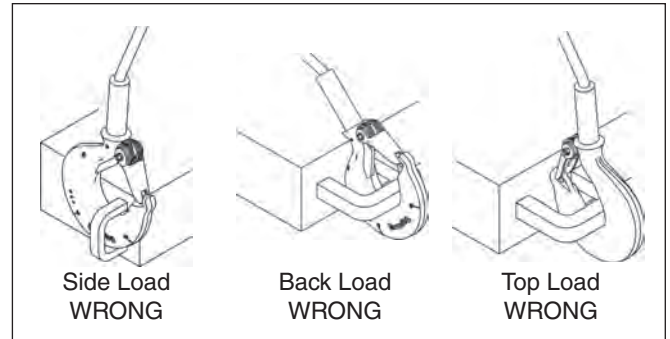

Figure 2

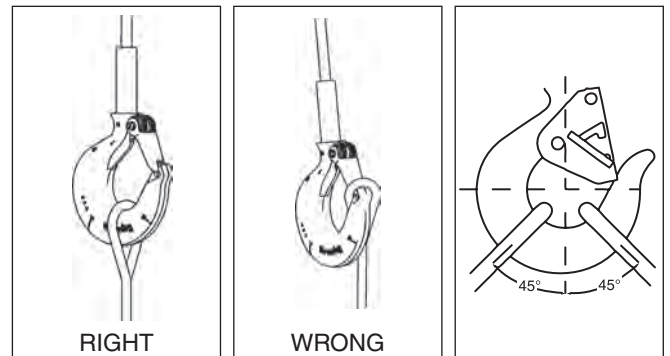

Figure 3

Figure 4

Figure 5

Wire Rope Size (in.)	Hook Frame I.D. Code	Required Swaging Die		Maximum After Swage Dimensions
		Stock No.	Description	
3/16	DC	1191621	1/8" Button	0.40
1/4	FC	1192845	1/4" Socket	0.46
5/16	GC	1191621	1/4" Button	0.46
5/16	HC	1192863	3/8" Socket	0.71
3/8	HC	1192863	3/8" Socket	0.71
7/16	IC	1192881	1/2" Socket	0.91
1/2	IC	1192881	1/2" Socket	0.91
9/16	JC	1192907	5/8" Socket	1.16
5/8	JC	1192907	5/8" Socket	1.16
3/4	KC	1192925	3/4" Socket	1.42
7/8	LC	1192949	7/8" Socket	1.55
1	NC	1192961	1" Socket	1.80
1-1/8	OC**	1192989	1-1/8" Socket	2.05

\*\* S319C Style Hook

# Swage Hook Terminations – 3/16" - 1"

S-319SWG Swage Hooks 3/16" through 1" (See page 55 for larger sizes).

S-319SWG Swage Hooks are swaged in specially designed National Swage dies with a relief and extra length. **All hooks should be swaged full shank.** To swage the hook, use the following procedure.

Step 1: For proper insertion, mark rope using Column Y Dimension on page 51.



Step 2: Slide rope into hook until it is fully inserted in the shank. Inspect mark for full insertion.



Step 3: Lubricate both die cavities and lower die face. See page 51 for proper die selection.



Step 4: 1st pass – allow dies to remain open approximately 1/2 the distance from time initial contact is made between hook and dies. Rotate fitting 45 to 90 degrees.



Step 5: 2nd pass – allow dies to remain open approximately 1/2 the distance from time initial contact is made between hook and dies. Rotate fitting 45 to 90 degrees.



Step 6: 3rd pass – If sharp flashing does not occur, close dies and rotate fitting 45 to 90 degrees.

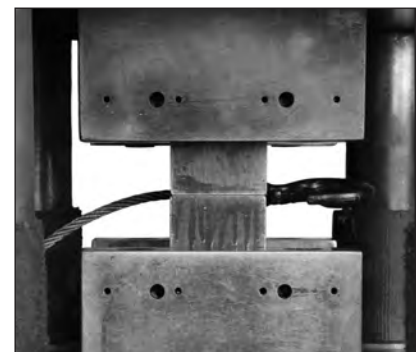

Step 7: 4th and 5th pass – Close dies to round fitting. Open dies and rotate 45 to 90 degrees between passes. **Open dies and check termination for proper after swage dimensions.** (See page 17 for proper use of No-Go Gauges).

QUIC-CHECK®

Additional swaging may be required to provide smooth finish and achieve proper after swage dimensions. **Dies must be fully closed before swaging is complete.**

# Swage Hook Terminations – 1 1/8" and Larger

S-319SWG Swage Hooks 1-1/8" and larger (See page 54 for smaller sizes).

S-319SWG Swage Hooks are swaged in specially designed National Swage dies with a relief and extra length. **All hooks should be swaged full shank.** To swage the hook, use the following procedure.

Step 1: For proper insertion, mark rope using Column Y Dimension on page 51.



Step 2: Slide rope into hook until it is fully inserted in the shank. Inspect mark for full insertion.



Step 3: Lubricate both die cavities and lower die face. See pages 51 for proper die selection.



Step 4: 1st pass – allow dies to remain open approximately 1/2 the distance from time initial contact is made between hook and dies. Rotate fitting 45 to 90 degrees.



Step 5: 2nd pass – allow dies to remain open approximately 1/2 the distance from time initial contact is made between hook and dies. Rotate fitting 45 to 90 degrees.



Step 6: 3rd pass – If sharp flashing does not occur, close dies and rotate fitting 45 to 90 degrees.

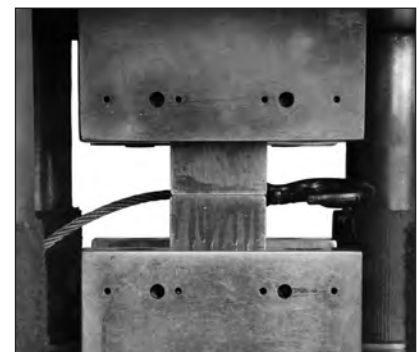

Step 7: 4th pass – Close dies to round fitting. **Open dies and check termination for proper after swage dimensions.** (See page 17 for proper use of No-Go Gauges).

Note: Limited swaging capacity may require the use of progressive swaging (See page 41).

QUIC-CHECK®

Additional swaging may be required to provide smooth finish and achieve proper after swage dimensions. **Dies must be fully closed before swaging is complete.**

# Swage Terminal Assemblies – Fatigue Life

## Relative Fatigue Life of Termination Assemblies

The chart below indicates the relative fatigue life of wire rope termination assemblies utilizing Crosby swage fittings. The findings are based upon the fatigue testing of assemblies under controlled laboratory conditions. The chart is for comparison only, not to determine the specific fatigue life values.

Refer to product section in this brochure to find the termination efficiency rating for each particular swaging product. Efficiency is calculated as a ratio of the ultimate strength of the termination assembly compared to the minimum breaking force of the wire rope. A rating is given for both Type I and Type II products.



S-501



S-502

Sockets



S-409

Buttons



S-505

Sleeves



S-506

Turnbacks

## Rope Types

Type II - 6 x 19 and 6 x 36 FC IPS RRL Wire Rope

Type I - 6 x 19 and 6 x 36 IWRC EIPS RRL Wire Rope

# Crosby® Spelter Terminations

**G-416  
Crosby Open  
Spelter Socket**



**G-417  
Crosby Closed  
Spelter Socket**



**G-517  
Crosby  
Mooring Socket**



**SB-427  
Crosby  
Button Socket**



**WIRELOCK®  
Socketing**



## Table of Contents

Spelter Termination – Application and General Information .....	58-59	Closed Spelter Sockets .....	62
Crosby Spelter Sockets .....	60	Crosby Mooring Sockets.....	63-64
Open Spelter Sockets.....	61	Crosby Button Spelter Sockets .....	65-67
		WIRELOCK® .....	69-95

# Spelter Terminations

## Application and General Information

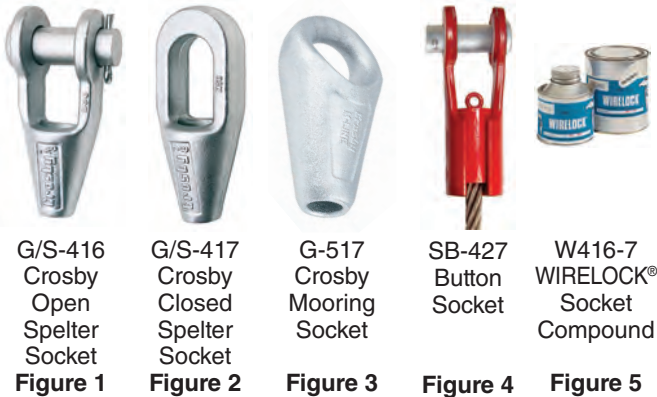

There are four basic types of sockets available from Crosby that utilize a poured zinc or resin to create the termination. Poured sockets are used in many wire rope and structural strand termination applications where a high strength, permanent end attachment is required.

Crosby Spelter Sockets are available in both the closed and open design (see Figure 1 and Figure 2 above). These types of poured sockets are generally used as a straight tension member. They are commonly used on crane boom pendant lines and on applications that require an anchoring system to be connected mechanically to a structure, such as on bridges and roof systems. They are also occasionally used on crane hoist lines to connect to a crane block or overhaul ball.

Crosby Mooring Sockets (See Figure 3) are designed to be used in marine applications where attachment to shackles and connecting links is required.

Crosby Button Sockets (see Figure 4) are designed to terminate all types of running ropes used on mobile cranes to connect a hoist line to a crane block or overhaul ball.

The common thread among all these products is the method used to terminate the rope. **WIRELOCK®** (see Figure 5) is a resin compound offered by Crosby, that when properly used, creates a 100% efficient termination. Zinc is also used to terminate spelter type sockets with the same resultant efficiency.

### Efficiency

Efficiency ratings for wire rope end terminations are based upon the minimum breaking force of wire rope.

When properly fabricated, all Crosby Spelter Sockets have a termination efficiency of 100 percent based on the minimum breaking force of the wire rope (see table at top of page). Ratings for Crosby Spelter Sockets are based on recommended use with 6 x 7, 6 x 19, or 6 x 36, IPS or XIP (EIP), XXIP (EEIP), RRL, FC, or IWRC wire rope.

Strand constructed with minimal number of wires (e.g. 1 x 7) requires special consideration that socket basket length be five (5) times the strand diameter or fifty (50) times the wire diameter, whichever is greater.

Product	Figure # from Left	Efficiency
G/S-416 Open Spelter Sockets	1	100%
G/S-417 Closed Spelter Sockets	2	100%
G-517 Mooring Sockets	3	100%
SB-427 Button Sockets	4	100%

## INSTALLATION INFORMATION

1. The spelter process begins by inserting the end of the wire rope into the narrow end of the cone shaped socket or button.
2. Before pouring the socket, the wire must be broomed and properly cleaned. Once the socket (or button) and wire rope are properly prepared, the broomed wire rope is pulled inside the socket cavity.
3. The socket (or button) cavity is then poured with molten zinc, or more commonly, an epoxy resin called **WIRELOCK®**.
4. The socket must then be allowed to cure based on zinc/resin manufacturer's recommendations.
5. Assembly length is measured from center line of pins for both open and closed sockets (bearing point to bearing point).

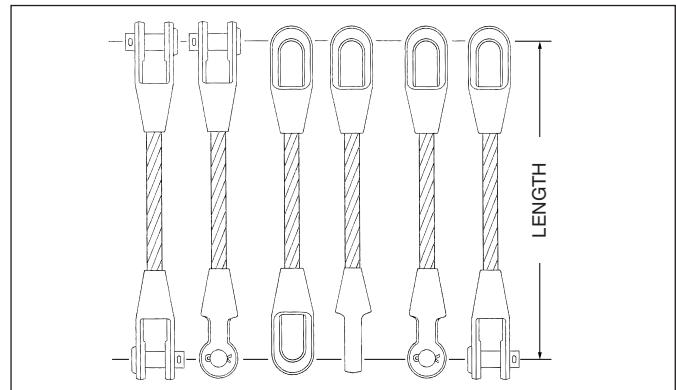

### Key Facts About Spelter Terminations:

1. Poured spelter sockets are occasionally used in sling applications. However, if used in a choker hitch sling application, the rated capacity must be reduced based on angle of choke. See wire rope capacity chart for complete information.
2. Assemblies with poured sockets can have tight tolerances. Tolerances as small as plus or minus 1/8 inch is not uncommon.
3. Specifications such as fitting type, orientation of pin, whether zinc or epoxy resin is to be used and type of application should be communicated to the fabricator of the socket assembly.
4. Proper training is required before attempting to pour sockets. See proper socketing procedures in following pages for complete information.

# Spelter Terminations

## Reuse of Crosby Spelter Sockets and Buttons

Crosby allows the reuse of sockets and buttons so long as recommended procedures are followed.

The following are general guidelines for the reuse of Crosby 416/417 Spelter Sockets and Crosby 427 Spelter Buttons. The use and inspection of used spelter sockets and buttons is the responsibility of the user.

### Procedure for Removing Spelter Cone

1. Cut the rope close (1/2") to the nose end of the socket/button and press the cone out of the basket of the socket.
2. We do not recommend the use of heat to remove the spelter cone for metallurgical, medical and environmental reasons.
  - A. However, if this is the only means available for removing the zinc cone, care should be taken not to exceed 850°F (450°C) surface temperature. The preferred method would be a slow heat in a temperature controlled oven. If a torch (rosebud) is used, the heat spot shall be monitored with a tempil stick or a temperature indicator to prevent localized heating from exceeding the 850°F (450°C) limit.
  - B. To remove a **WIRELOCK**® cone, heat the surface of the socket/button to 350°F (177°C). Do not exceed the 850°F (450°C) limit for any localized hot spot. Leave for 5-10 minutes, then drive the cone out with a hammer and drift.

### Selection of Sockets and Buttons for Reuse

1. Use only sockets/buttons that do not show discoloration from excessive heating or any signs of welding.
2. Select only sockets/buttons that have been cleaned and have passed a Magnetic Particle Inspection by a qualified technician (Level II ASNT-SNT-TC-1A-88) per ASTM E709. Acceptance criteria shall be per ASTM E125, Types II-VIII, Degree 1. No cracks are acceptable.
3. Select only sockets/buttons that do not show any signs of overloading or wear on the socket or pin, (ie. elongated pin holes, undersized pins, etc.).
4. Select sockets/buttons that are free from nicks, gouges and abrasions. Indications may be repaired by lightly grinding until surfaces are smooth, provided they do not reduce the dimensions by more than 10% of the nominal catalog dimension.
5. Select sockets/buttons that are not distorted, bent or deformed.

**Note: Sockets/Buttons having any of the indications as outlined above (1-5) shall not be reused.**

### Procedures For Speltering Sockets & Buttons

1. The proper procedure for speltering sockets can be found in the *Wire Rope User's Manual, 3rd Edition*,

*Appendix C, American Petroleum Institute (API) Recommended Practice 9B (RP9B), 11th Edition, September, 2002 or ISO17558:2006 Steel Wire Ropes Socketing Procedures – Molten Metal and Resin Socketing.*

2. Some standards (API, ISO, BSI) recommend preheating of the zinc spelter socket/button before pouring. This temperature shall not exceed 850°F (450°C).
3. Resin spelter sockets/buttons shall follow the procedure outlined by the resin manufacturer (See **WIRELOCK**®, Pages 73-77).

### Proof Testing

We recommend the socketed assembly be proof tested at two (2) times the Working Load Limit (2 x WLL) assigned to the socketed assembly.

## STANDARD CONSIDERATIONS

### ASME B30.9

All slings terminated with sockets shall be proof loaded. The proof load shall be a minimum of 2 and a maximum of 2.5 times the single leg vertical hitch rated load. The proof load should be that specified by the wire rope or fitting manufacturer's recommendation provided that it is within the above specified proof load range. When sockets are used in sling assemblies the minimum recommended design factor is 5.

### ASME B30.5

Cranes require that boom pendants terminated with sockets be proof tested. When sockets are used in boom pendant lines, the minimum recommended design factor is 3.

See OSHA and ASME for full information.

# Crosby® Spelter Sockets

## Speltering Methods for G&S 416 and 417 Sockets

Crosby Spelter Sockets are available in both the closed and open design. These types of poured sockets are generally used as a straight tension member. They are commonly used on crane boom pendant lines and applications that require an anchoring system to be connected mechanically to a structure, such as on bridges and roof systems. They are also occasionally used on crane hoist lines to connect to a crane block or overhaul ball.

### Efficiency

When properly fabricated, all Crosby Spelter Sockets have a termination efficiency of 100 percent based on the minimum breaking force of the wire rope (see table on page 58).

Ratings for Crosby Spelter Sockets are based on recommended use with 6 x 7, 6 x 19, or 6 x 36, IPS or XIP (EIP), XXIP (EEIP), RRL, FC, or IWRC wire rope.

Strand constructed with minimal number of wires (e.g. 1 x 7) requires special consideration that socket basket be five (5) times the strand diameter or fifty (50) times the wire diameter, whichever is the greater.

**Before using any Crosby fitting with any other type lay, construction or grade of wire rope, it is recommended that the termination be destructive tested and documented to prove the adequacy of the assembly to be manufactured.**

### Installation Information

#### General Overview

1. The spelter socket is attached by inserting the end of the wire rope into the narrow end of the cone shaped socket.
2. Before pouring the socket, the wire must be broomed and properly cleaned. Once the socket and wire rope are properly prepared, the broomed wire rope is pulled into the socket cavity.
3. The socket cavity is then poured with molten zinc, or more commonly, an epoxy resin called **WIRELOCK®**.
4. The socket must then be allowed to cure based on zinc/resin manufacturer's recommendations.
5. Assembly length is measured from center line of pins for both open and closed sockets.

#### Specific Instructions

#### Socketing Using **WIRELOCK®** Resin Material:

Seizing, cleaning, brooming and preparation of wire rope and pouring of **WIRELOCK®** is to be carried out per instructions provided in the Wire Rope End Terminations User's Manual (see pages 73-77 in this document), and **WIRELOCK®** Warnings and Application Instructions located on the **WIRELOCK®** Product or in the Crosby® General Catalog.



#### Socketing using Zinc Spelter Material:

Seizing, cleaning, brooming and preparation of the wire rope, and pouring of zinc is to be carried out in accordance with recommendations of the Wire Rope User's Manual, 3rd Edition, Appendix C, American Petroleum Institute (API) Recommended Practice 9B (RP9B), 11th Edition, September, 2002 or ISO17558:2006 Steel Wire Ropes Socketing Procedures – Molten Metal and Resin Socketing.

**Before operation of the wire rope assembly, it is recommended that all poured sockets, whether with zinc or resin, be proof loaded to seat the cone.**

#### Reuse of Crosby Spelter Sockets and Buttons

Crosby allows the reuse of sockets so long as recommended procedures are followed.

Refer to Page 59 for recommended procedures for reuse of Crosby Spelter Sockets.

### STANDARD CONSIDERATIONS

#### ASME B30.9

All slings terminated with sockets shall be proof loaded. The proof load shall be a minimum of 2 and a maximum of 2-1/2 times the single leg vertical hitch rated load. The proof load should be that specified by the wire rope or fitting manufacturer's recommendation provided that it is within the above specified proof load range. When sockets are used in sling assemblies the minimum recommended design factor is 5.

#### ASME B30.5

Cranes require that boom pendants terminated with sockets be proof tested. When sockets are used in boom pendant lines, the minimum recommended design factor is 3.

See OSHA and ASME for full information.

# Open Spelter Sockets

## G-416 / S-416



Open grooved sockets meet the performance requirements of Federal Specification RR-5-550D, Type A, except for those provisions required of the contractor. For additional information, see Crosby General Catalog.

- Forged steel sockets through 1-1/2", cast alloy steel 1-5/8" through 4".
- Spelter socket terminations have an efficiency rating of 100%, based on the catalog strength of wire rope. Ratings are based on recommended use with 6 x 7, 6 x 19, or 6 x 36, IPS or XIP (EIP), XXIP (EEIP), RRL, FC, or IWRC wire rope. Strand constructed with minimal number of wires (e.g. 1 x 7) requires special consideration that socket basket be five (5) times the strand diameter or fifty (50) times the wire diameter, whichever is the greater.

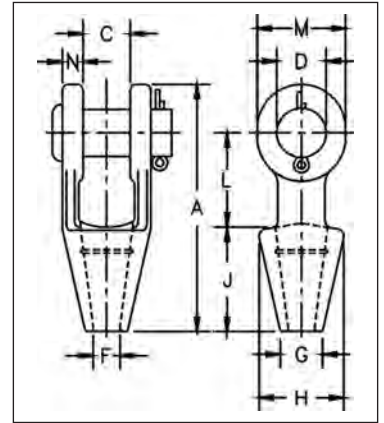

NOTICE: All cast steel sockets 1-5/8" and larger are magnetic particle inspected and ultrasonic inspected. Proof testing available on special order.

Drawing illustrates one groove used on sockets 1/4" through 3/4". Sizes 7/8" through 1-1/2" use 2 grooves. Sizes 1-5/8" and larger use 3 grooves.

## G-416 / S-416 Open Spelter Sockets

Rope Dia.		Structural Strand Dia. (in.)	Ultimate Load (t)	Stock No.		Weight Each (lbs.)	Dimensions (in.)									
(in.)	(mm)			G-416 Galv.	S-416 S.C.		A	C	D	F	G	H	J	L	M	N
1/4	6-7	—	4.5	1039619	1039628	1.10	4.56	.75	.69	.38	.69	1.56	2.25	1.56	1.31	.36
5/16-3/8	8-10	—	12	1039637	1039646	1.30	4.84	.81	.81	.50	.81	1.69	2.25	1.75	1.50	.44
7/16-1/2	11-13	—	20	1039655	1039664	2.25	5.56	1.00	1.00	.56	.94	1.88	2.50	2.00	1.88	.50
9/16-5/8	14-16	1/2	27	1039673	1039682	3.60	6.75	1.25	1.19	.69	1.13	2.25	3.00	2.50	2.25	.56
3/4	18	9/16-5/8	43	1039691	1039708	5.83	7.94	1.50	1.38	.81	1.25	2.62	3.50	3.00	2.62	.62
7/8	20-22	11/16-3/4	55	1039717	1039726	9.65	9.25	1.75	1.63	.94	1.50	3.25	4.00	3.50	3.13	.80
1	24-26	13/16-7/8	78	1039735	1039744	15.50	10.56	2.00	2.00	1.13	1.75	3.75	4.50	4.00	3.75	.88
1-1/8	28-30	15/16-1	92	1039753	1039762	21.50	11.81	2.25	2.25	1.25	2.00	4.12	5.00	4.62	4.12	1.00
1-1/4 - 1-3/8	32-35	1-1/16 - 1-1/8	136	1039771	1039780	31.00	13.19	2.50	2.50	1.50	2.25	4.75	5.50	5.00	4.75	1.13
1-1/2	38	1-3/16 - 1-1/4	170	1039799	1039806	47.25	15.12	3.00	2.75	1.63	2.75	5.25	6.00	6.00	5.38	1.19
* 1-5/8	* 40-42	1-5/16 - 1-3/8	188	1039815	1039824	55.00	16.25	3.00	3.00	1.75	3.00	5.50	6.50	6.50	5.75	1.31
* 1-3/4 - 1-7/8	* 44-48	1-7/16 - 1-5/8	268	1039833	1039842	82.00	18.25	3.50	3.50	2.00	3.13	6.38	7.50	7.00	6.50	1.56
* 2 - 2-1/8	* 50-54	1-11/16 - 1-3/4	291	1039851	1039860	129.00	21.50	4.00	3.75	2.25	3.75	7.38	8.50	9.00	7.00	1.81
* 2-1/4 - 2-3/8	* 56-60	1-13/16 - 1-7/8	360	1039879	1039888	167.00	23.50	4.50	4.25	2.50	4.00	8.25	9.00	10.00	7.75	2.13
* 2-1/2 - 2-5/8	* 64-67	1-15/16 - 2-1/8	424	1041633	1041642	252.00	25.50	5.00	4.75	2.88	4.50	9.25	9.75	10.75	8.50	2.38
* 2-3/4 - 2-7/8	* 70-73	2-3/16 - 2-7/16	511	1041651	1041660	315.00	27.25	5.25	5.00	3.12	4.88	10.50	11.00	11.00	9.00	2.88
* 3 - 3-1/8	* 75-80	2-1/2 - 2-5/8	563	1041679	1041688	380.00	29.00	5.75	5.25	3.38	5.25	11.12	12.00	11.25	9.50	3.00
* 3-1/4 - 3-3/8	* 82-86	2-3/4 - 2-7/8	722	1041697	1041704	434.00	30.88	6.25	5.50	3.62	5.75	11.88	13.00	11.75	10.00	3.12
* 3-1/2 - 3-5/8	* 88-92	3 - 3-1/8	779	1041713	1041722	563.00	33.25	6.75	6.00	3.88	6.50	12.38	14.00	12.50	10.75	3.25
* 3-3/4 - 4	* 94-102	—	875	1041731	1041740	783.00	36.25	7.50	7.00	4.25	7.25	13.62	15.00	13.50	12.50	3.50

\* Cast Alloy Steel.

NOTE: Available with bolt, nut and cotter. Contact Crosby for more information.

t = metric tons.

# Closed Spelter Sockets

## G-417 / S-417



Closed grooved sockets meet the performance requirements of Federal Specification RR-S-550D, Type B, except for those provisions required of the contractor. For additional information, see Crosby General Catalog.

- Forged steel sockets through 1-1/2", cast alloy steel 1-5/8" through 4".
- Spelter socket terminations have an efficiency rating of 100%, based on the catalog strength of wire rope. Ratings are based on the recommended use with 6 x 7, 6 x 19 or 6 x 36, IPS or XIP (EIP), XXIP (EEIP), RRL, FC or IWRC wire rope. Strand constructed with minimal number of wires (e.g. 1 x 7) requires special consideration that socket basket be five (5) times the strand diameter or fifty (50) times the wire diameter, whichever is the greater.

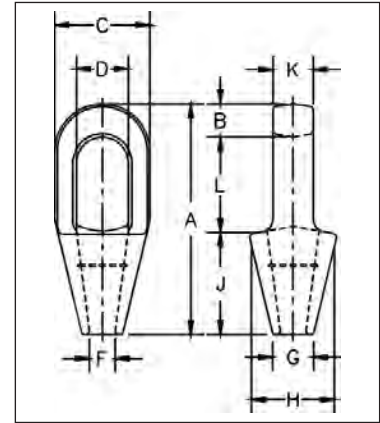

**NOTICE:** All cast steel sockets 1-5/8" and larger are magnetic particle inspected and ultrasonic inspected. Proof testing available on special order.

Drawing illustrates one groove used on sockets 1/4" through 3/4". Sizes 7/8" through 1-1/2" use 2 grooves. Sizes 1-5/8" and larger use 3 grooves.

## G-417 / S-417 Closed Spelter Sockets

Rope Dia.		Structural Strand Dia. (in.)	Ultimate Load (t)	Stock No.		Weight Each (lbs.)	Dimensions (in.)									
(in.)	(mm)			G-417 Galv.	S-417 S.C.		A	B	C	D*	F	G	H	J	K	L
1/4	6-7	—	4.50	1039897	1039904	.50	4.50	.50	1.50	.88	.38	.69	1.56	2.25	.50	1.75
5/16 - 3/8	8-10	—	12.0	1039913	1039922	.75	4.94	.62	1.69	.97	.50	.81	1.69	2.25	.69	2.06
7/16 - 1/2	11-13	—	20.0	1039931	1039940	1.50	5.50	.69	2.00	1.16	.56	.94	2.00	2.50	.88	2.31
9/16 - 5/8	14-16	1/2	30.8	1039959	1039968	2.50	6.31	.81	2.63	1.41	.69	1.12	2.38	3.00	1.00	2.50
3/4	18	9/16 - 5/8	43.5	1039977	1039986	4.25	7.62	1.06	3.00	1.66	.88	1.25	2.75	3.50	1.25	3.06
7/8	20-22	11/16 - 3/4	65.3	1039995	1040000	7.25	8.75	1.25	3.63	1.94	1.00	1.50	3.25	4.00	1.50	3.50
1	24-26	13/16 - 7/8	81.6	1040019	1040028	10.50	9.88	1.38	4.13	2.30	1.13	1.75	3.75	4.50	1.75	4.00
1-1/8	28-30	15/16 - 1	100	1040037	1040046	14.25	11.00	1.50	4.50	2.56	1.25	2.00	4.13	5.00	2.00	4.50
1-1/4 - 1-3/8	32-35	1-1/16 - 1-1/8	136	1040055	1040064	19.75	12.12	1.63	5.00	2.81	1.50	2.25	4.75	5.50	2.25	5.00
1-1/2	38	1-3/16 - 1-1/4	170	1040073	1040082	29.20	13.94	1.94	5.38	3.19	1.63	2.75	5.25	6.00	2.50	6.00
† 1-5/8	† 40-42	1-5/16 - 1-3/8	188	1040091	1040108	36.00	15.13	2.13	5.75	3.25	1.75	3.00	5.50	6.50	2.75	6.50
† 1-3/4 - 1-7/8	† 44-48	1-7/16 - 1-5/8	268	1040117	1040126	57.25	17.25	2.19	6.75	3.75	2.00	3.13	6.38	7.50	3.00	7.56
† 2 - 2-1/8	† 50-54	1-11/16 - 1-3/4	309	1040135	1040144	79.00	19.87	2.44	7.63	4.38	2.25	3.75	7.38	8.50	3.25	8.81
† 2-1/4 - 2-3/8	† 56-60	1-13/16 - 1-7/8	360	1040153	1040162	105.00	21.50	2.75	8.50	5.00	2.63	4.13	8.25	9.00	3.63	9.75
† 2-1/2 - 2-5/8	† 64-67	1-15/16 - 2-1/8	424	1041759	1041768	140.00	23.50	3.12	9.50	5.50	2.88	4.50	9.25	9.75	4.00	10.62
† 2-3/4 - 2-7/8	† 70-73	2-3/16 - 2-7/16	549	1041777	1041786	220.00	25.38	3.12	10.75	6.25	3.12	4.88	10.19	11.00	4.88	11.25
† 3 - 3-1/8	† 75-80	2-1/2 - 2-5/8	656	1041795	1041802	276.00	27.12	3.37	11.50	6.75	3.38	5.25	11.50	12.00	5.25	11.75
† 3-1/4 - 3-3/8	† 82-86	2-3/4 - 2-7/8	750	1041811	1041820	313.00	29.25	4.00	12.25	7.25	3.62	5.75	12.25	13.00	5.75	12.25
† 3-1/2 - 3-5/8	† 88-92	3 - 3-1/8	820	1041839	1041848	400.00	31.00	4.00	13.00	7.75	3.88	6.31	13.00	14.00	6.25	13.00
† 3-3/4 - 4	† 94 - 102	—	1005	1041857	1041866	542.00	33.25	4.25	14.25	8.50	4.25	7.25	14.25	15.00	7.00	14.00

\* Diameter of pin must not exceed pin used on companion 416 Socket. Reference adjacent page "D" dimension.

† Cast Alloy Steel.

t = metric tons.

# Crosby® Mooring Sockets

## Speltering Methods for G-517 Mooring Sockets

Crosby Mooring Sockets are designed to be used in marine applications where attachment to shackles and connecting links is required.

### Efficiency

When properly fabricated, all Crosby Mooring Sockets have a termination efficiency of 100 percent based on the minimum breaking force of the wire rope (see table on page 58).

Ratings for Crosby Mooring Sockets are based on recommended use with 6 x 7, 6 x 19, or 6 x 36, IPS or XIP (EIP), XXIP (EEIP), RRL, FC, or IWRC wire rope.

Strand constructed with minimal number of wires (e.g. 1 x 7) requires special consideration that socket basket be five (5) times the strand diameter or fifty (50) times the wire diameter, whichever is the greater.

Before using any Crosby fitting with any other type lay, construction or grade of wire rope, it is recommended that the termination be destructive tested and documented to prove the adequacy of the assembly to be manufactured.

### Installation Information

#### General Overview

1. The socket is attached by inserting the end of the wire rope into the narrow end of the cone shaped socket.
2. Before pouring the socket, the wire must be broomed and properly cleaned. Once the socket and wire rope are properly prepared, the broomed wire rope is pulled into the socket cavity.
3. The socket cavity is then poured with molten zinc, or more commonly, **WIRELOCK®** resin.
4. The socket must then be allowed to cure based on zinc/resin manufacturer's recommendations.
5. Assembly length is measured from center line of pins for both open and closed sockets.

#### Specific Instructions

#### Socketing Using **WIRELOCK®** Resin Material:

Seizing, cleaning, brooming and preparation of wire rope and pouring of **WIRELOCK®** is to be carried out per instructions provided in the pages 73-77 in this document, and **WIRELOCK®** Warnings and Application Instructions located on the **WIRELOCK®** Product or in the Crosby® General Catalog.



#### Socketing Using Zinc Spelter Material:

Seizing, cleaning, brooming and preparation of the wire rope, and pouring of zinc is to be carried out in accordance with recommendations of the Wire Rope User's Manual, 3rd Edition, Appendix C, American Petroleum Institute (API) Recommended Practice 9B (RP9B), 11th Edition, September, 2002 or ISO17558:2006 Steel Wire Ropes Socketing Procedures – Molten Metal and Resin Socketing.

**Before operation of the wire rope assembly, it is recommended that all poured sockets, whether with zinc or resin, be proof loaded to seat the cone.**

#### Reuse of Crosby Mooring Sockets

Crosby allows the reuse of sockets so long as recommended procedures are followed.

Refer to Page 59 for recommended procedures for reuse of Crosby Spelter Sockets.

#### Key Facts About Wire Rope Spelter Sockets:

1. Design of bail allows for easy connection to shackles and other connecting links.
2. Socket design utilizes features to keep cone from rotating.

# Mooring Sockets

## G-517



- Wide range of sizes available:
  - 1-1/4" thru 4" wireline
- "M-Line" socket terminations have a 100% efficiency rating, based on the catalog strength of the wire rope. Ratings are based on recommended use with 6 x 7, 6 x 19, or 6 x 36, IPS or XIP (EIP), XXIP (EEIP), RRL, FC, or IWRC wire rope. Strand constructed with minimal number of wires (e.g. 1 x 7) requires special consideration that socket basket be five (5) times the strand diameter or fifty (50) times the wire diameter, whichever is the greater.
- Galvanized finish.
- Designed for today's higher strength classes of wire rope.
- Design of bail allows for easy connection to shackles and other connecting links.
- Socket design utilizes features to keep cone from rotating.

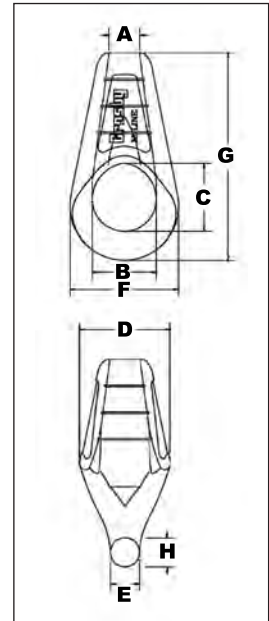

NOTICE: All Cast Mooring Sockets are Individually Magnetic Particle Inspected and Ultrasonic Inspected.

## G-517 "M-Line" Mooring Sockets

Wire Rope Size		G-517 Stock No.	Ultimate Load (t)	Weight Each (lbs.)	Dimensions (in.)							
(in.)	(mm)				A	B	C	D	E	F	G	H
1-1/4 - 1-3/8	32-35	1004943	113	17	1.63	3.09	3.63	4.45	1.44	5.13	10.89	1.53
1-1/2 - 1-5/8	38-41	1004961	136	30	1.95	3.69	4.32	5.43	1.60	6.31	13.00	1.81
1-3/4 - 1-7/8	44-48	1004989	181	43	2.23	4.16	4.53	6.30	1.84	7.22	14.11	2.09
2 - 2-1/8	50-54	1005002	227	57	2.50	4.75	5.26	7.02	2.09	8.25	16.02	2.24
2-1/4 - 2-3/8	57-60	1005020	277	76	2.78	5.25	5.78	7.72	2.31	9.16	17.90	2.62
2-1/2 - 2-5/8	64-67	1005048	363	106	3.05	5.88	6.71	8.53	2.69	10.13	19.89	2.66
2-3/4 - 2-7/8	70-73	1005066	454	138	3.33	6.50	7.13	9.35	3.00	11.09	21.63	2.98
3 - 3-1/8	76-79	1005084	544	193	3.50	7.25	7.74	10.30	3.25	12.31	23.50	3.24
3-1/4 - 3-3/8	82-86	1005105	635	229	3.81	7.62	8.80	10.94	3.50	13.13	25.75	3.43
3-1/2 - 3-5/8	88-92	1005123	735	279	4.15	8.00	9.06	11.72	3.69	13.96	27.70	4.12
3-3/4 - 4	95-102	1005141	907	384	4.39	8.75	10.50	12.91	3.69	15.88	30.13	4.46

t = metric tons.

# Crosby® Button Sockets

## Speltering Methods for SB-427 Button Sockets

Crosby Button Sockets are designed to terminate all types of running ropes used on mobile cranes, to connect hoist line.

### Efficiency

When properly fabricated, all Crosby Button Sockets have a termination efficiency of 100 percent based on the minimum breaking force of the wire rope (see table on page 58).

Ratings for Crosby Button Sockets are based on recommended use with 6 x 7, 6 x 19, or 6 x 36, IPS or XIP (EIP), XXIP (EEIP), RRL, FC, or IWRC wire rope.

**Before using any Crosby fitting with any other type lay, construction or grade of wire rope, it is recommended that the termination be destructive tested and documented to prove the adequacy of the assembly to be manufactured.**

### Installation Information

Install button on the rope so that the live end of the rope extends out of small diameter of the button. Broomed end of rope should be inserted to the "MAX FILL" line marked on the button to ensure correct length of engagement with socketing material and allow installation of pulling eye.

#### Socketing Using WIRELOCK® Resin Material:

Seizing, cleaning, brooming and preparation of wire rope and pouring of WIRELOCK® is to be carried out per instructions provided in the pages 73-77 in this document, and WIRELOCK® Warnings and Application Instructions located on the WIRELOCK® Product or in the Crosby® General Catalog.

#### Socketing using Zinc Spelter Material:

Seizing, cleaning, brooming and preparation of the wire rope, and pouring of zinc is to be carried out in accordance with recommendations of Appendix C, or other approved procedures.



**Before operation of the wire rope assembly, it is recommended that all poured sockets, whether with zinc or resin, be proof loaded to seat the cone.**

#### Reuse of Crosby Button Sockets

Crosby allows the reuse of sockets so long as recommended procedures are followed.

Refer to Page 59 for recommended procedures for reuse of Crosby Spelter Sockets.

#### Key Facts About Wire Rope Button Sockets:

1. Can be used to terminate high performance, rotation resistant ropes and standard 6 strand ropes.
2. Easy to install assembly utilizes Crosby® WIRELOCK® socketing compound.
3. Sockets and buttons are reusable.
4. Replacement buttons and sockets are available.
5. Locking feature available to prevent rotation of rope.
6. Button contains cap with eye that can be attached to, and used to pull rope during reeving process.

# Button Spelter Sockets

## SB-427



- Available in six (6) sizes from 1/2" to 1-1/2", (13mm - 38mm).
- Button Spelter terminations have a 100% efficiency rating, based on the catalog strength of the wire rope.
- Designed for use with mobile cranes. Can be used to terminate high performance, rotation resistant ropes, and standard six (6) strand ropes.
- Easy to install assembly utilizes Crosby® WIRELOCK® socketing compound.
- Sockets and buttons are reusable.
- Replacement buttons and sockets are available.
- Locking feature available to prevent rotation of rope.
- Button contains cap with eye that can be attached to, and used to pull rope during reeving process.

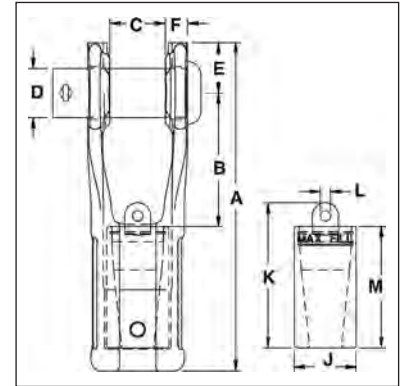

## SB-427 Button Spelter Sockets

Wire Rope Size		SB-427 Stock No.	Ultimate Load (t)	Weight Each (lbs.)	Socket Only Stock No.	Button Only Stock No.	Dimensions (in.)									
(in.)	(mm)						A	B	C	D	E	F	J	K	L	M
1/2 - 5/8	13-16	1052005	27	6.1	1052107	1052309	7.94	3.23	1.28	1.19	1.22	.57	1.50	3.50	.25	2.93
5/8 - 3/4	16-19	1052014	45	10.3	1052116	1052318	9.44	3.88	1.53	1.38	1.44	.66	1.75	4.28	.38	3.43
3/4 - 7/8	19-22	1052023	57	17.1	1052125	1052327	10.81	4.41	1.78	1.62	1.69	.75	2.06	4.78	.38	3.96
7/8 - 1	22-26	1052032	82	29.2	1052134	1052336	12.88	5.48	2.03	2.00	2.00	.89	2.44	5.62	.62	4.52
1-1/8 - 1-1/4	28-32	1052041	136	46.0	1052143	1052345	14.90	5.68	2.53	2.25	2.50	1.11	2.94	7.08	.75	5.72
1-3/8 - 1-1/2	35-38	1052050	161	78.0	1052152	1052354	18.06	7.17	3.03	2.75	2.75	1.24	3.62	8.08	.75	6.76

## SB-427TB (Bolt, Nut and Cotter Pin)

Wire Rope Size		SB-427 Stock No.	Ultimate Load (t)	Weight Each (lbs.)	Socket Only Stock No.	Button Only Stock No.	Dimensions (in.)									
(in.)	(mm)						A	B	C	D	E	F	J	K	L	M
1/2 - 5/8	13-16	1052406	27	6.1	1052107	1052309	7.94	3.23	1.28	1.19	1.22	.57	1.50	3.50	.25	2.93
5/8 - 3/4	16-19	1052415	45	10.3	1052116	1052318	9.44	3.88	1.53	1.38	1.44	.66	1.75	4.28	.38	3.43
3/4 - 7/8	19-22	1052424	57	17.1	1052125	1052327	10.81	4.41	1.78	1.62	1.69	.75	2.06	4.78	.38	3.96
7/8 - 1	22-26	1052433	82	29.2	1052134	1052336	12.88	5.48	2.03	2.00	2.00	.89	2.44	5.62	.62	4.52
1-1/8 - 1-1/4	28-32	1052442	136	46.0	1052143	1052345	14.90	5.68	2.53	2.25	2.50	1.11	2.94	7.08	.75	5.72
1-3/8 - 1-1/2	35-38	1052451	161	78.0	1052152	1052354	18.06	7.17	3.03	2.75	2.75	1.24	3.62	8.08	.75	6.76

## Wirelock Requirements

Wire Rope Size		WIRELOCK® Required (cc)	WIRELOCK® Stock No.	WIRELOCK® Kit Size (cc)
(in.)	(mm)			
1/2 - 5/8	13-16	35	1039602	100
5/8 - 3/4	16-19	60	1039602	100
3/4 - 7/8	19-22	100	1039602	100
7/8 - 1	22-26	140	1039602*	100
1-1/8 - 1-1/4	28-32	250	1039604	250
1-3/8 - 1-1/2	35-38	420	1039606	500

\* 2 kits required.  
t = metric tons.

# Button Spelter Sockets

## CROSBY® SPELTER BUTTON SB-427B APPLICATION INSTRUCTIONS



This procedure is provided to give instructions for installation of wire rope into the Crosby® SB-427B Spelter Button using **WIRELOCK®** socketing material or zinc socketing material. **Additionally, instructions regarding the reuse of spelter buttons are included.** The spelter button is part of a socket assembly that includes a socket basket, pin, cotter pin and button. If there are any questions regarding these instructions, please contact The Crosby Group LLC at (918) 834-4611 and request technical assistance.

NOTE: Many high performance ropes require special attention to prevent rope damage during cutting, seizing and brooming in preparation for the speltering operation. Attention to the special instructions is required to insure proper termination efficiency. Consult rope manufacturer for specific details.

### Installation:

Install button on the rope so that the live end of the rope extends out of small diameter of the button. Broomed end of rope should be inserted to the "MAX FILL" line marked on the button to ensure correct length of engagement with socketing material.

### Socketing Using WIRELOCK® Resin Material:

Seizing, cleaning, brooming and preparation of wire rope and pouring of **WIRELOCK®** is to be carried out per instructions provided in the **WIRELOCK® Technical Data Manual**, and **WIRELOCK® Warnings and Application Instructions** located on the **WIRELOCK® Product** or in the Crosby® General Catalog.

### Socketing Using Zinc Spelter Material:

Seizing, cleaning, brooming and preparation of the wire rope, and pouring of zinc is to be carried out in accordance with recommendations of the *Wire Rope User's Manual, 3rd Edition, Appendix C*, or other approved procedures.

Before operation of the wire rope assembly, it is recommended that all poured sockets, whether with zinc or resin, be proof loaded to seat the cone.

### Reuse of Crosby® Spelter Buttons:

The following are general guidelines for the reuse of a Crosby® SB-427B Button. The use and inspection of used buttons are the responsibility of the user.

#### Procedure For Removing Spelter Cone

- Cut the rope close ( $\frac{1}{2}$ " ) to the nose end of the button and press the cone out of the button.
- For metallurgical, medical and environmental reasons, we do not recommend the use of heat to remove the spelter cone.
  - However, if this is the only means available for removing the zinc cone, care should be taken not to exceed 850°F (450°C) surface temperature. The preferred method would be a slow heat in a temperature controlled oven. If a torch (rosebud) is used, the heat spot shall be monitored with a tempil stick or a temperature indicator to prevent localized heating from exceeding the 850°F (450°C) limit.
  - To remove a **WIRELOCK®** cone, heat the surface of the button to 350°F (177°C). Do not exceed the 850°F (450°C) limit for any localized hot spot. Leave for 5-10 minutes, then drive the cone out with a hammer and drift.

#### Selection of Buttons For Reuse

- Use only buttons that:
  - Do not show discoloration from excessive heating.
  - Do not show any signs of welding.
  - Select only buttons that have been cleaned and have passed a Magnetic Particle Inspection by a qualified technician (Level II ASNT-SNT-TC-1A-88) per ASTM E709. Acceptance criteria shall be per ASTM E125, Types II-VIII, Degree 1. No cracks are acceptable.
  - Select only buttons that do not show any signs of overloading or wear.
  - Select buttons that are free from nicks, gouges and abrasions. Indications may be repaired by lightly grinding until surfaces are smooth, provided they do not reduce the dimensions by more than 10% of the nominal catalog dimension.
  - Select buttons that are not distorted, bent or deformed.

**NOTE: Buttons having any of the indications as outlined above shall not be reused.**

# DO NOT BE FOOLED...

You could be putting lives and your business at risk for a few pennies.

There are suppliers who would like you to believe swaging sleeves are a commodity. Don't be fooled, IT'S NOT SO!

***The Crosby COLD-TUFF® process is the difference.***



- Since 1973, Crosby's proprietary COLD-TUFF® heat treat process has made swaging sleeves more reliable during the demanding conditions of swaging.
- COLD-TUFF® virtually eliminates the cracking of sleeve during the swaging process, especially at extremely low temperatures.
- The steel microstructure created from the COLD-TUFF® heat treatment process reveals a uniform structure in the Crosby sleeve, that result in Charpy impact values averaging up to ten times greater than those of competitive sleeves. See photo lower left.
- The improved steel microstructure provides increased resistance to cracks that can occur during the sling building process. Cracks are initiated at stress risers.
  - Crosby COLD-TUFF® sleeves dramatically reduce the effects of stress risers that can occur during swaging, where the "cold worked" sleeve makes contact with the wire. Stress risers are not detectable through visual inspection. See photo at right.
  - Because of the higher Charpy values found in Crosby COLD-TUFF® sleeves, stress risers caused by stenciling are not detrimental.



COLD-TUFF® process results in superior ductility that reduces the effects of stress risers.

## Un-retouched Photomicrographs of Sleeve (Original Magnification @ 500x)



### Crosby COLD-TUFF® Heat Treatment

The *uniform* microstructure of the COLD-TUFF® process results in superior ductility and toughness properties.



### Competitor's Heat Treatment

The *non-uniform* microstructure may lack proper ductility and toughness required for swaging and use.

## ***The Mark Of Quality Is On Every National Sleeve***

Crosby or CG and COLD-TUFF are clearly stenciled on every sleeve we make (legible even after swaging) leaving no question as to the quality or the manufacturer.

**Crosby COLD-TUFF® and National Swage Fittings  
Reliability You Can Depend On**

# Crosby®

[www.thecrosbygroup.com](http://www.thecrosbygroup.com)



# WIRELOCK®



## Table of Contents

General Information.....	70-71	Reuse of Socket .....	77
Warning on Correct Application of <b>WIRELOCK®</b> .....	73	Approvals.....	78
Safety and Health Precautions for Using <b>WIRELOCK®</b> .....	73	NATO Numbers.....	78
Selection of Socket.....	73	Guide to Amount of <b>WIRELOCK®</b> Required .....	79
Preparation of Broom.....	74	Properties of <b>WIRELOCK®</b> .....	80
Positioning of Broom and Alignment of Socket.....	75	Certificate of Testing .....	81
Materials .....	75	Compression Test Results .....	82
Use of Heat.....	76	<b>Appendix A</b>	
Pouring .....	76	Material Safety Data Sheets (MSDS) .....	83-86
Movement.....	76	<b>Appendix B</b>	
Check on Penetration .....	77	Resin Socketing of Steel Wire Rope.....	87-92
Re-Lubrication .....	77	<b>Appendix C</b>	
Loading.....	77	Technical Bulletin “Reuse of Sockets” .....	93
		<b>WIRELOCK®</b> Warnings and Application Instructions .....	94-95

# WIRELOCK® Socketing Compound

**WIRELOCK®** is a unique socketing compound for use with wire ropes. The product eliminates the hazards of working with a molten metal, and allows socketing to be done on site, when required, in virtually all weather conditions.

**WIRELOCK®** is generally used in long term applications such as crane ropes, boom pendants, winches, lifting straps, mast stays, suspended roofs, bridges, mining and offshore mooring systems.

## Efficiency

When fabricated properly, **WIRELOCK®** wire rope assemblies are 100% efficient based on the minimum breaking force of the wire rope. **WIRELOCK®** is designed to be used with steel wire rope, galvanized wire ropes and stainless steel wire ropes.

## Installation Information

### Socketing Using WIRELOCK® Resin Material:

Seizing, cleaning, brooming and preparation of wire rope and pouring of **WIRELOCK®** is to be carried out per instructions provided in the **WIRELOCK®** Technical Data Manual located in this manual on Page 73-77, and the **WIRELOCK®** Warnings and Application Instructions located on the **WIRELOCK®** Product or in the Crosby® General Catalog.

**Before operation of the wire rope assembly, it is recommended that all poured sockets, whether with zinc or resin, be proof loaded to seat the cone.**

## Facts about WIRELOCK®



1. **WIRELOCK®** is designed to gel (change from a liquid to a solid), in approximately 20 minutes at 65°F (18°C). To ensure that the kits are not adversely affected by storage, they should be stored in a dry place at a temperature of between 50°F and 75°F (10°C and 24°C) and away from any source of



direct heat. **WIRELOCK®**, like all polyester resins, is temperature sensitive. An increase in temperature of 15°F (10°C) shortens the gel time by approximately 50%. A decrease in temperature of 15°F (10°C) lengthens the gel time by approximately 100%.

### 2. KIT SIZES

100 cc  
250 cc  
500 cc  
1000 cc  
2000 cc

Other sizes available to order.

The specific gravity of **WIRELOCK®** is 1.73. Therefore, 1000 cc's will weigh 1.73 kilos or 3.81 lbs. 250 cc's will weigh

**$1.73 \times 250 = 0.43$  kilos or  $0.95$  lbs.**  
**1000**

3. **WIRELOCK®** Wire Rope Assemblies are 100% efficient when used with steel wire rope, galvanized wire ropes and stainless steel wire ropes. We do not advise the use of stainless steel wire rope in a salt water marine environment without regular inspection. In the presence of an electrolyte, i.e., sea water, electrolytic degradation of the stainless steel wire rope can occur. This phenomenon, known as crevice corrosion, will impair the integrity of the rope in the region near to the neck of the socket. Crevice corrosion also occurs when white metal is used for socketing. (Zinc should not be used to socket stainless steel rope.) However, the onset of crevice corrosion in resin sockets appears to be faster than when white metal is used. Other rope types do not exhibit this behavior.
4. **WIRELOCK®** is approximately 20% the weight of zinc.
5. The strength of **WIRELOCK®**, in its cured state, is not

# WIRELOCK® Socketing Compound



Typical example of the swelling of stainless steel rope due to crevice corrosion

adversely affected by cold temperatures.

6. **WIRELOCK®** must be mixed and poured (see 6.3) within the temperature range of 27°F - 95°F (-3°C - 35°C). The kits are not adversely affected by storage at temperatures below 27°F (-3°C). It is recommended the **WIRELOCK®** kit be stored in a cool place.
7. The operating temperature of **WIRELOCK®** is +240°F to -65°F (+115°C to -54°C).
8. When cured, **WIRELOCK®** has a hardness of approximately 55 Barcol. When the resin has set fully (opaque green or mustard color) only a slight scratch mark will be seen when a sharp object, such as a screwdriver blade, is scraped over the surface of the resin. On a small socket, it is quite normal to have a very thin tacky layer on the surface of the resin. The scratch test can be carried out through this layer.
9. Cracks which may appear on the top of the cured cone are surface crazing only, and are the result of heat stresses and shrinkage upon a thin layer of unfilled resin covering the tops of the wires. The crazing does not affect the strength of the termination within the socket.
10. Shrinkage of the **WIRELOCK®** cone may leave a gap between the cone and the socket wall. This is normal, particularly with large sockets and high ambient temperatures. This in no way affects the efficiency of the assembly. Upon loading, the cone will be seated perfectly in the socket. The shrinkage of **WIRELOCK®** is between 1.5 - 2.0%. In high volume **WIRELOCK®**, the shrinkage is about 0.5%.
11. Excessive numbers of horizontal rings in the socket may increase the load required to “seat” and wedge the cone within the socket. They should be avoided whenever possible, and a proof load applied (not exceeding 60% of MBL) if they must be used. Alternatively, they should be filled in with clay prior to placing the socket on the rope.
12. **WIRELOCK®** poured sockets should not be used

in environments of strong caustic or acid solutions. **WIRELOCK®** is not affected by oils, or grease or salt water.

13. **WIRELOCK®** is, by design, a compressive resin. Therefore, when removed from the socket a **WIRELOCK®** cone, if hit by a hammer, may shatter. In a socket, even under extreme loads or shockloads, the **WIRELOCK®** cone remains solid and 100% efficient.
14. The shelf life of **WIRELOCK®** is eighteen (18) months (check label before use) from the date of manufacture.

## Worldwide Agency Approvals

- ✓ Lloyds Register of Shipping
- ✓ Det Norske Veritas
- ✓ American Bureau of Shipping
- ✓ United States Coast Guard
- ✓ Registro Italiano Navale
- ✓ Germanischer Lloyd

## STANDARD CONSIDERATIONS

### ASME B30.9

All slings terminated with sockets shall be proof loaded. The proof load shall be a minimum of 2 and a maximum of 2-1/2 times the single leg vertical hitch rated load. The proof load should be that specified by the wire rope or fitting manufacturer’s recommendation provided that it is within the above specified proof load range. When sockets are used in sling assemblies the minimum recommended design factor is 5.

### ASME B30.5

Cranes require that boom pendants terminated with sockets be proof tested. When sockets are used in boom pendant lines the minimum recommended design factor is 3.

See OSHA and ASME for full information.

# WIRELOCK®

## RESIN FOR SPELTER SOCKETS NOT AVAILABLE IN CANADA

**Note: For use on 416, 417, 427 and 517 spelter sockets only.**

- 100% termination efficiency.
- Temperature operating range is -65° F to +240° F (-54°C to +116°C).
- Ideal for on site applications.
- No hazardous molten metal.
- Improved fatigue life.
- Pouring temperature without booster pack is 48° F to 110° F (6.67°C to 43.3°C).
- One booster pack if pouring temperature is 35° F to 48° F (1.67°C to 8.89°C).
- Two booster packs if pouring temperature is 27° F to 35° F (-2.78°C to +1.67°C).
- Refer to WIRELOCK® Technical Manual for more information.



**SEE APPLICATION AND WARNING INFORMATION**  
Para Español: [www.thecrosbygroup.com](http://www.thecrosbygroup.com) On Pages 94-95

### Approvals:

Lloyds Register of Shipping  
Det Norske Veritas (DNV)  
United States Coast Guard  
United States Navy  
American Bureau of Shipping  
ISO 17.558  
DNV-OS-E304

### WIRELOCK® W416-7 Socket Compound

Kit Size	W416-7 Kits			Booster Pak Stock No.
	Kit Per Case	Stock No.	Weight Each (lbs.)	
100	20	1039602	.62	1039603
250	12	1039604	1.25	1039605
500	12	1039606	2.54	1039607
1000	12	1039608	4.59	1039609
2000	12	1039610	9.00	1039611

### Guide to amount of WIRELOCK® Required

Wire Rope Size		WIRELOCK® Required (cc)	Wire Rope Size		WIRELOCK® (cc)
(in.)	(mm)		(in.)	(mm)	
1/4	6-7	9	1-3/4	44	700
5/16	8	17	1-7/8	48	700
3/8	9-10	17	2	51	1265
7/16	11	35	2-1/8	54	1265
1/2	13	35	2-1/4	56	1410
9/16	14	52	2-3/8	60	1410
5/8	16	52	2-1/2	64	1830
3/4	20	86	2-5/8	67	1830
7/8	22	125	2-3/4	70	2250
1	26	160	3	76	3160
1-1/8	28	210	3-1/4	82	3795
1-1/4	32	350	3-1/2	88	4920
1-3/8	36	350	3-3/4	94	5980
1-1/2	40	420	4	102	7730
1-5/8	42	495	—	—	—

Wirelock is a hazardous material regulated by US DOT, ICAO/IATA and IMO for transportation.



### NATO Numbers:

100 cc 8030-21-902-1823  
250 cc 8030-21-902-1824  
500 cc 8030-21-902-1825  
1000 cc 8030-21-902-1826

Witnessed and tested by American Bureau of Shipping. (ABS)

### Approximate U.S. Measurements:

250 cc's Kit 1 Cup

# WIRELOCK®

## DETAILED INSTRUCTIONS FOR THE USE OF WIRELOCK®

With Strand or General Purpose Wire Rope

**These instructions explain the proper use of WIRELOCK® for socketing wire rope terminations. When reading and following these instructions, pay close attention to warnings and safety information presented in bold print.**

For maximum safety and efficiency, use **WIRELOCK®** only as instructed.

### 1. Warning on Correct Application of WIRELOCK®

It is very important when deciding upon the use of **WIRELOCK®** to note the following:

#### **WARNING**

- **Incorrect use of WIRELOCK® can result in an unsafe termination which may lead to serious injury, death, or property damage.**
- **Do not use WIRELOCK® with stainless steel rope in salt water environment.**
- **Use only soft annealed iron wire for seizing.**
- **Do not use any other wire (copper, brass, stainless, etc.) for seizing.**
- **Never use an assembly until the WIRELOCK® has gelled and cured.**
- **Remove any non-metallic coating from the broom area.**
- **Non Crosby sockets with large grooves need to have those grooves filled before use with WIRELOCK®.**
- **Read, understand and follow these instructions and those on product containers before using WIRELOCK®.**

### 2. Safety and Health Precautions for Using WIRELOCK®

It is very important that certain precautions be taken when using **WIRELOCK®** for a wire rope socket termination. When using the product, be sure to read information on product containers and note the following:

#### **CAUTION**

- **WIRELOCK® resin, in liquid state, is flammable.**
- **Chemicals used in this product can give off toxic fumes and can burn eyes and skin.**
- **Never use out-of-date material.**
- **Use only in well ventilated work areas.**
- **Never breathe fumes directly or for extended time.**
- **Always wear safety glasses to protect eyes.**
- **Always wear gloves to protect hands.**
- **Avoid direct contact with skin anywhere.**

### 3. Selection of Socket

- 3.1 **WIRELOCK®** is recommended for use with sockets that comply with Federal or International (CEN, ISO) Standards.
- 3.2 **WIRELOCK®** as with all socketing media, depends upon the wedging action of the cone within the socket basket to develop full efficiency. A rough finish inside the socket may increase the load at which seating will occur. Seating is required to develop the wedging action.
- 3.3 Measure the rope ends to be socketed. The rope end should be of sufficient length so that the ends of the unlaied wires (from the strands) will be at the top of the socket basket.
- 3.4 Next, apply the seizing one (1) socket basket length from the end of the rope minus one (1) rope diameter. The length of the seizing must be at least two (2) rope diameters long. Additional information can be secured from your Wire Rope Users Manual or your Wire Rope Manufacturers' Catalogs or National Standard. Seizing wire should be a soft annealed iron wire.



Seizing of Wire Rope

- 3.5 Plastic coated or plastic filled wire ropes must have all plastic material (non-metallic materials) removed from within the broomed area.
- 3.6 The socket basket should be examined prior to use and loose scale, dirt or grease removed.  
**Do not use oversized sockets for Wire Rope.**
- 3.7 When socketing Strand, the time honoured method of one size up when choosing the socket is generally still applicable in the vast majority of cases. However, caution should be exercised as tests have shown that the length of the socket basket should be five (5) times the strand diameter or fifty (50) times the maximum wire diameter, whichever is the greater.
- 3.8 **Inserting the broom into the socket.**

There are two procedures that can be used to position the broom within the socket. The rope

can be inserted into the socket prior to brooming. Subsequently the socket can be pulled up over the broom. The second method requires that the broom is closed and compacted to enable it to be inserted into the socket without damaging the rope.

For detailed explanation of Resin Socketing of Steel Wire Rope, see Page 88.

## 4. Preparation of Broom

- 4.1 The rope is secured in a vice directly below the seizing to allow the strands to be unlaidd to the seizing. They should be bent outwards to an included angle not exceeding 90 degrees. (Fig. 1)
- 4.2 Internal leakage of resin in ropes 3" (75mm) in diameter and larger can occur because of gaps between strands and the IWRC (Independent Wire Rope Core). These gaps should be sealed (before brooming), by pushing small plugs of the sealing compound down into the served portion.
- 4.3 If the rope has a fiber core, it should be cut out insuring that the remaining fiber core extends 1/2 rope diameter into the bottom of the socket. In the case of fiber cores, resin is the preferred socketing medium.

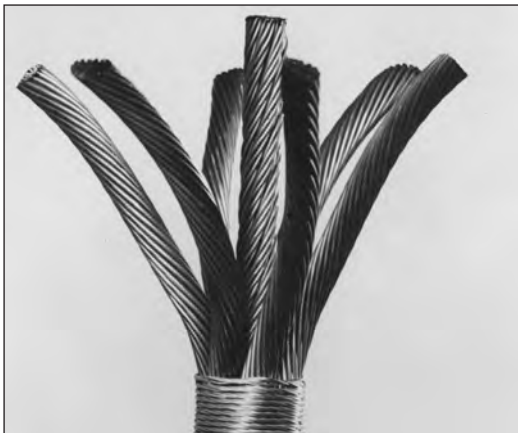

Unlay wire rope so that angle does not exceed 90° (Fig. 1)

- 4.4 If the rope has an IWRC, the IWRC shall be completely unlaidd to form part of the broom.
- 4.5 **All the wires in each strand and in the IWRC must be unlaidd completely down to the seizing to form a broom, being careful not to disturb or change the lay of the wires and strands under the seizing band. The wires should not be straightened.**

**Brooming is one of the most critical parts of any socketing operation.**

**Note: The wires must be unlaidd from the end of the rope to the seizing** because a good fill of resin must occur to the bottom (small end) of the socket. (Fig. 2). **Most of the load capacity of the termination is concentrated in the bottom one-third of the socket.**

- 4.6 Except in the case of wire ropes of coarse construction e.g., 6 x 7, it is not necessary or desirable to hook the wires in the broom. When the rope contains large numbers of wires, hooking the ends causes congestion within the socket and can create penetration problems for the socketing medium, although this is less of a problem with resin than with zinc or white metal.
- 4.7 The open broom shall be thoroughly cleaned (degreased). **Be sure that the cleaning is confined to the broom and does not extend to the rope beyond.**



Properly Broomed Wire Rope (Fig. 2)



Incorrectly Broomed Wire Rope

- 4.8 The method of cleaning will depend on the lubricant and/or coating on the wire.
- 4.9 The methods and materials used for cleaning should comply with the current EPA regulations.
- 4.10 Consult the Wire Rope Technical Board, your Wire Rope supplier or the Wire Rope Manufacturer for recommended materials and methods.
- 4.11 **Do not clean the wire rope broom with acid, soda, methol hydrate or acetone. A flux should not be used.**
- 4.12 The wire rope broom, after cleaning and drying, should be kept in an upright position to prevent any grease, or mixture of grease and cleaner, from

running back down from the main body of the rope and contaminating the clean wires.

## 5. Positioning of Broom and Alignment of Socket

5.1 The broom should be inserted into the socket using one of the methods described in 3.8. Place rope in a vertical position with the broom end up. It is recommended that there be thirty (30) rope diameters below the socket before any bending occurs in the rope, or twenty (20) rope diameters if securely clamped to a beam.

**Make certain the broomed wires are uniformly spaced in the basket, with wire ends at the top edge of the basket, (Fig 3), and that the axes of the rope and the fitting are aligned. A centralizing clamp should be used to assist in the alignment of the axes of the socket and the rope (Fig 4 and Fig 5).**

**Correct alignment will avoid premature failure of the assembly due to unequal loading of the wires.**



Properly positioned broom with wire rope ends protruding slightly (Fig. 3)

5.2 Plasticine or clay based putty, i.e. window or glazing putty, is required to seal the base of the socket prior to pouring, thus preventing resin leakage which may cause voids. (Fig. 4 and 5)

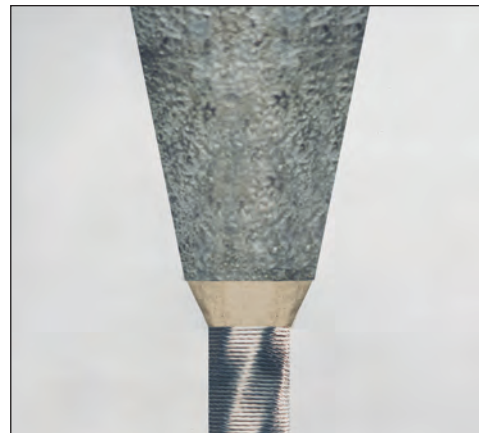

Axes of socket and rope properly aligned and sealed with plasticine (Fig. 4)



Clamp used to align rope and socket before sealing with plasticine (Fig. 5)

## 6. Materials

- 6.1 Always check expiration date on the cans. Never use out-of-date material. **WIRELOCK®** should be stored in a cool 50°F - 75°F (10°C - 24°C) dry place.
- 6.2 **WIRELOCK®** is formulated for mixing and pouring in the ambient temperature range: 27°F – 95°F (-3°C – 35°C). At lower temperatures the gel time will increase. Below 48°F (9°C) the gel time of approximately 20 minutes can be maintained by the use of booster packs.
- 6.3 At ambient temperatures below 48°F (9°C) and above 35°F (2°C), one (1) booster pack should be used. Below 35°F (2°C) and above 27°F (-3°C), two (2) booster packs should be used. The booster pack compensates chemically for the slower gel time experienced at lower temperatures. In order to comply with all the approvals granted, **WIRELOCK®** should not be mixed and poured at temperatures below 27°F (-3°C). Knowing the ambient temperature is useful – however, it should be remembered **WIRELOCK®** will for some time afterwards tend to cure according to the temperature at which it, the socket and the wire rope were stored. The temperature of the socket

### ⚠ CAUTION

- Wirelock resin, in liquid state, is flammable.
- Chemicals used in this product can give off toxic fumes and can burn eyes and skin.
- Never use out-of-date material.
- Always check expiration date on the cans. Never use out of date material.
- Use only in well ventilated work areas.
- Never breathe fumes directly or for extended time.
- Always wear safety glasses to protect eyes.
- Always wear gloves to protect hands.
- Avoid direct contact with skin anywhere.

and the rope should conform to the temperature at which the **WIRELOCK®** has been stored for the last 24 hours. When the sockets, rope and **WIRELOCK®** are stored at normal room temperature (65 to 70°F or 18 to 21°C), booster packs must not be used even if the ambient temperature is below 48°F (9°C). If the temperature is above 95°F (35°C) the **WIRELOCK®** kit should be refrigerated for two hours before use.

- 6.4 It is possible to combine various kit sizes to achieve any required volume, e.g., 2500 cc = 1 x 1000 cc plus 3 x 500 cc, etc. In this case, all of the liquid resin should be placed in the mixing container and then all of the powder added to it (or vice versa) before mixing. **Always mix all of the resin with all of the powder. Never mix less than the total contents of all cans.**



Some kits can be mixed in the original packaging (Fig. 6)

- 6.5 **Only the 100cc, 250cc & 500cc can be mixed in the original packaging by pouring the resin into the granular materials container. In the case of other kits, a proper mixing vessel should be used (Fig 6).**

Mixing vessels should be clean. They can be of metal, polythene or polypropylene. Polymerization products of styrene, i.e. styrofoam cups and similar products should not be used. A flat wooden or metal paddle, not a spike or screwdriver, should be used as a stirrer.

- 6.6 Immediately upon pouring the resin into the granular compound (or vice versa), mix vigorously for two (2) minutes or until a homogenous mixture has been obtained. Make sure that no unmixed granular compound remains on the bottom of the mixing container. For larger sizes, a mechanical mixer is ideal.

**Upon mixing, the **WIRELOCK®** will turn to a greenish / turquoise colour. If the mix remains a pale straw yellow colour, do not use the kit. Always mix all of the resin with all of the powder. Never mix less than the total contents of both cans.**

## 7. Use of Heat

- 7.1 Do not apply heat to sockets to accelerate the curing process prior to pouring. The application of external heat may cause the resin to gel before it reaches the bottom of the socket and lead to assembly failure. Used sockets cleaned out by heating (see Appendix D) should be allowed to cool to room temperature before reuse.

**Hot sockets must not be used.**

## 8. Pouring

- 8.1 Once the **WIRELOCK®** is mixed, it should be poured immediately (Fig. 7) into the socket to ensure good penetration, preferably down the side of the socket to allow air to escape.



Upon mixing, the compound should be poured immediately (Fig. 7)

Immediate pouring will ensure that the gelling stage occurs in the socket and not in the mixing container. Sufficient **WIRELOCK®** should be mixed so that the socket can be completely filled at one pouring. **WIRELOCK®** is designed to gel in approximately 15 minutes and to cure within 60 minutes after gel. To provide an adequate safety margin, no load should be applied to the wire rope assembly until a minimum of one (1) hour has elapsed from the time the **WIRELOCK®** gels in the socket. As the **WIRELOCK®** cures, a chemical (exothermic) reaction occurs, causing a considerable rise in temperature.

Temperatures in excess of 212°F (100°C), may be reached in large volume kits in the mixing container. In the socket where the wires of the rope and the socket itself act as a heat sink, the maximum temperature likely to be achieved will be of the order of 160°F - 175°F (70°C - 80°C).

## 9. Movement

- 9.1 Movement of resin poured sockets may damage the soft resin and reduce the efficiency of the termination. Resin poured sockets should not be moved for a minimum of ten (10) minutes after the material **in the socket** has gelled.

## 10. Check on Penetration

10.1 A visual check for penetration of the resin into the socket bottom can be made by removing the centralizing clamp and the plasticine or putty. Seizing on the rope adjacent to the neck of the socket should be removed up to the point where it enters the socket.

## 11. Re-Lubrication

11.1 After removing the rope from the vice, any degreased area of the rope below the socket should be re-lubricated.

## 12. Loading

12.1 The rope can be put into service or proof loaded one (1) hour after the material in the socket has gelled.

12.2 Whenever possible, the assembly should be Proof Loaded in accordance with ASME B30.9-2.6.

## 13. Reuse of Socket

13.1 To remove the resin from the socket:

- a. Cut the rope close to the base of the socket (1/2" is about right).
- b. Press the rope and cone out of the socket or,
- c. Heat the surface of the socket to 350°F (177°C). Leave for 5-10 minutes. Force out the rope and cone with a drift pin and hammer.

13.2 For additional information on reuse of sockets, see Appendix C "Technical Bulletin #1" by The Crosby Group LLC (page 93).

# Approvals

## Approvals:

- ✓ Lloyds Register Of Shipping
- ✓ Det Norske Veritas
- ✓ United States Coast Guard
- ✓ United States Navy
- ✓ American Bureau of Shipping



U.S. Department  
of Transportation  
United States  
Coast Guard



## NATO Numbers:

100cc 8030-21-902-1823  
250cc 8030-21-902-1824  
500cc 8030-21-902-1825  
1000cc 8030-21-902-1826

Witnessed and tested by American Board of Shipping (ABS)

## Manufactured by:

MILLFIELD ENTERPRISES (MANUFACTURING) LIMITED  
Shelley Road, Newburn Industrial Estate,  
Newburn, Newcastle upon Tyne  
NE15 9RT United Kingdom

## Distributed by:

The Crosby Group LLC  
P.O. Box 3128  
Tulsa, Oklahoma 74101  
Telephone: (918) 834-4611  
Fax: (918) 832-0940  
[www.thecrosbygroup.com](http://www.thecrosbygroup.com)  
[crosbygroup@thecrosbygroup.com](mailto:crosbygroup@thecrosbygroup.com)

# WIRELOCK® Formula for Spelter Sockets

## WIRELOCK® Formula to estimate CC's required to pour standard spelter sockets

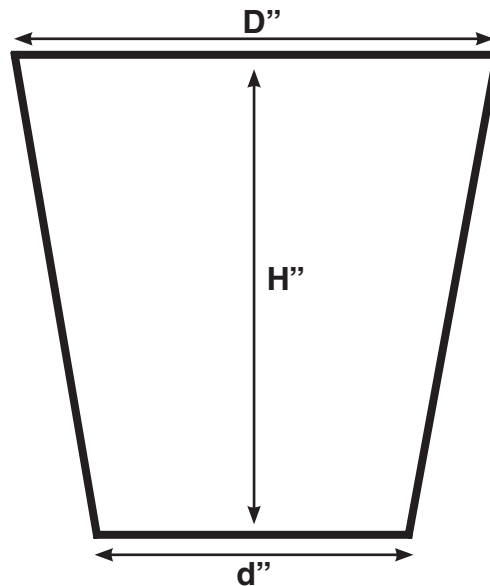

$$\left(\frac{D + d}{4}\right)^2 \times H \times 3.142 = \text{cc}$$

Note: D, d and H are in centimeters

## GUIDE TO AMOUNT OF WIRELOCK® REQUIRED

1/4" (6.5mm) .....	9cc	1-3/4" (44.5mm) .....	700cc
5/16" (8mm) .....	17cc	1-7/8" (47.5 mm) .....	700cc
3/8" (9.5mm) .....	17cc	2" (51mm) .....	1265cc
7/16" (11mm).....	35cc	2-1/8" (54mm).....	1265cc
1/2" (12.5mm) .....	35cc	2-1/4" (57mm).....	1410cc
9/16" (14mm) .....	52cc	2-3/8" (60mm).....	1410cc
5/8" (16mm) .....	52cc	2-1/2" (63.5mm).....	1830cc
3/4" (19mm) .....	86cc	2-5/8" (66.5mm).....	1830cc
7/8" (22mm) .....	125cc	2-3/4" (70mm).....	2250cc
1" (25mm) .....	160cc	3" (76mm) .....	3160cc
1-1/8" (28.5mm) .....	210cc	3-1/4" (82.5mm).....	3795cc
1-1/4" (32mm) .....	350cc	3-1/2" (89mm).....	4920cc
1-3/8" (35mm) .....	350cc	3-3/4" (95mm).....	5980cc
1-1/2" (38mm) .....	420cc	4" (101.5mm).....	7730cc
1-5/8" (41mm) .....	495cc		

### Note – Approximate Measurements (U.S.A.)

250cc Kit.....	1 Cup
500cc Kit.....	1 Pint
1000cc Kit.....	1 Quart

# Properties of WIRELOCK®

## Physical

Viscosity	3 - 4 Poise
Heat Distortion Point	212° Fahrenheit (100°C) to 240° Fahrenheit (115°C)
Flexural Strength	1500 lb./sq. in.
Flexural Modulus	5.8 x 10 <sup>5</sup> lb. sq. in.
Tensile Strength	1.09T/in <sup>2</sup> (16.15N/mm <sup>2</sup> )
Flashpoint	89°F (31°C)

## Electrical

Dielectric Strength	230 volts/mm
Arc Resistance	191 S
Volume Resistivity	Greater than 14.5 log <sub>10</sub> ohms/cm
Surface Resistance	14.0 log <sub>10</sub> ohms/cm
Insulation Resistance	8.2 x 10 <sup>12</sup> log <sub>10</sub> ohms/cm

## Flashpoint

Please note that this is not the auto ignition (spontaneous combustion) temperature, but the temperature above which the material will give off a significant amount of vapor.

Graph A

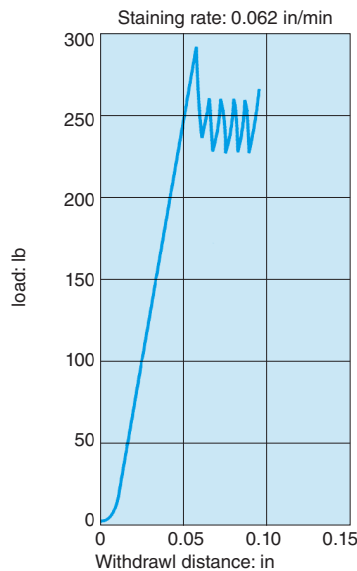

Graph B

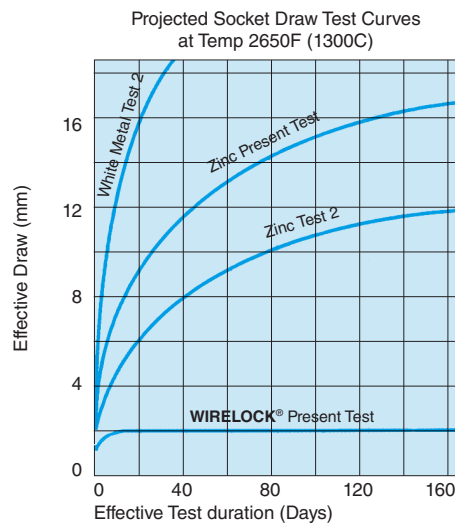

The individual wires of the rope are retained by a combination of bonding and frictional forces. The frictional forces are the result of:

- Shrinkage during the curing of the resin.
- Coefficient of friction between the resin and the individual wires.

Additional forces develop due to the wedge action of the socket as the rope is loaded.

As **WIRELOCK®** cures, it shrinks by between 1.5% and 2.5% (High Volume **WIRELOCK®** by less than 0.5%), and with the introduction of a hard inert filler of specific grain size, a high coefficient of friction is obtained.

**WIRELOCK®** has excellent penetrating qualities and can flow through the most dense wire rope broom, which would impede the flow of zinc.

The **WIRELOCK®** system is designed to have a minimal amount of creep, which ceases once the wedging and frictional forces develop for any given load

**WIRELOCK®** excels in its ability to resist the action of fatigue – fatigue in a wire rope assembly is normally prevalent in the rope close to the neck of the socket **WIRELOCK®** will minimize such problems.

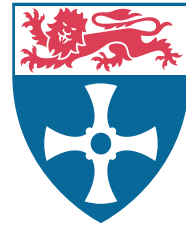

Department of Civil Engineering

Cassie Building  
University of Newcastle  
Newcastle upon Tyne NE1 7RU  
United Kingdom  
Head of Department  
Professor B G Clarke

11-Mar-99

Millfield Enterprises  
16 Shelley Road  
Newcastle upon Tyne 15

Job No 99R007  
Test Compressive Strength and Stiffness of Resin  
Sample 31436/R1792/T40

The specimens were prepared, cured and sent to us by the client.

Date of test 02/03/99  
Ambient conditions during the test 20°C 60%RH  
Testing machine Avery 250kN Compression Testing Machine

Sample Compressive	Weight g	Height (after grind) mm	Width mm	Depth mm	Density Mg/m <sup>3</sup>	Compressive	
						Load kN	Strength MPa
31436/R1792/T40-1	101.3	37.5	39.1	39.6	1.74	180.6	116.7
31436/R1792/T40-3	102.2	37.5	39.1	39.6	1.76	187.8	121.3
31436/R1792/T40-5	102.7	37.5	39.1	39.6	1.77	189.6	122.5
31436/R1792/T40-2	104.0	37.5	39.6	39.6	1.77	203.5	129.8
31436/R1792/T40-4	103.2	37.5	39.6	39.6	1.75	196.7	125.4
31436/R1792/T40-6	103.0	37.5	39.6	39.6	1.75	191.0	121.8
average					1.76		124.1

Sample	Min Stress MPa	Max Stress MPa	Mean Strain	Modulus of Elasticity N/mm <sup>2</sup>
31436/R1792/T40-1	0.0	58.3	0.243%	1.20E+04
31436/R1792/T40-3	0.0	60.6	0.263%	1.17E+04
31436/R1792/T40-5	0.0	61.2	0.234%	1.27E+04
average				1.21E+04

*Renewed  
S. DM  
31.3.99*

RECEIVED  
15 MAR 1999

*B. G. Clarke*

Professor B G Clarke  
Head of Department

Telephone • 0191 222 6000  
Fax • 0191 222 6502

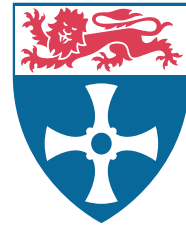

BGC/AEB

21st September 1995

Millfield Enterprises Ltd.  
16 Shelley Road  
Newcastle upon Tyne  
NE15 9RT

Department of Civil Engineering  
Cassie Building  
University of Newcastle  
Newcastle upon Tyne NE1 7RU  
United Kingdom  
Head of Department  
Professor B G Clarke

## Compression Test of Resin Cubes

40mm nominal cubes were supplied. The specimens were cooled by immersing them in a mixture of dry ice and acetone. The temperature was monitored using a similar control specimen containing a thermistor. A specimen was placed between two platens cooled to  $-18^{\circ}\text{C}$  in a refrigerator. The control specimen was also placed between two similarly cooled platens. The specimens were loaded until failure at a rate of 72kN/min.

Specimen	Height	Length	Width	Weight	Bulk Density	Cooling Temperature	Temperature of failure	Max Load	Failure Stress
	mm	mm	mm	g	Mg/m <sup>3</sup>	$^{\circ}\text{C}$	$^{\circ}\text{C}$	kN	N/mm <sup>2</sup>
1	39.7	39.6	40.0	110.9	1.76	-44	-30	203	128
2	39.3	39.3	39.7	108.7	1.77	-55	-30	215	138
3	39.6	39.5	39.7	107.2	1.73	-60	-30	207	132
4	39.6	39.6	39.6	108.1	1.74	-1	-28	204.5	130
5	39.8	39.6	39.7	109.1	1.74	-73	-36	200	127
6	39.7	39.9	39.7	109.2	1.74	74	-38	207	131

B G Clarke

Direct dial - 0191 222 6888

Switchboard - 0191 222 6000

Fax - 0191 222 6613

Telex - 53654 (UNIN EW G)

Copyright © 2018 The Crosby Group LLC  
All Rights Reserved

# Material Safety Data Sheet

## MSDS

Complies with OSHA Hazard Communication Standard  
29 CFR 1910.1200

# Crosby®



MATERIAL SAFETY  
DATA SHEET

MSDS Revision date  
01/02/2012

### WIRELOCK ROPE CAPPING KIT (Resin System)

#### SECTION 1 : IDENTIFICATION OF THE SUBSTANCE OR PREPARATION AND THE COMPANY/UNDERTAKING

- 1.1 **Product Identifier** : WIRELOCK ROPE CAPPING KIT (RESIN SYSTEM)
- 1.2 **Product use** : The attachment of Sockets to Wire Rope.  
The kit consists of:  
1. Polyester resin dissolved in styrene and other inhibitors. (RESIN)  
2. Pure silica granules, Dibenzoyl Peroxide and inert fillers (POWDER)
- 1.3 **Chemical Family** : Mixture
- 1.4 **Manufacturers name and address** : Millfield Enterprises (Manufacturing) Limited,  
16 Shelley Road,  
Newburn Industrial Estate,  
Newburn,  
Newcastle upon Tyne,  
NE15 9RT  
England
- 1.5 **Emergency Telephone** : +44 (0) 191 2648541

#### SECTION 2 HAZARDS IDENTIFICATION

- 2.1 **Classification of Substance or Mixture**  
**Product Definition** : Mixture  
Classification according to Regulation (EC) No. 1272/2008 (CLP/GHS)
- |             |   |       |
|-------------|---|-------|
| Flam. Liq.  | 3 | H226  |
| Acute Tox.  | 4 | H332  |
| Skin Irrit. | 2 | H315  |
| Eye Irrit.  | 2 | H319  |
| STOT SE     | 3 | H335  |
| STOT RE     | 1 | H372i |

See section 16 for the full text of the H statements declared above

#### Classification according to Directive 1999/45/EC (DPD)

The product is classified as dangerous according to directive 1999/45/EC and its amendments.

- Classification** : R10  
Xn R20,R48/20  
Xi R36/37/38
- Physical/chemical hazards** : Flammable
- Human Health Hazards** : Harmful by inhalation. Irritating to eyes, respiratory system and skin. Harmful: danger of serious damage to health by prolonged exposure through inhalation.
- Environmental Hazards** : Based on available data of this product, no hazardous properties are known.

See section 16 for the full text of the R-phrases declared above

- 2.2 **Label Elements**
- |                          | Pack 1 RESIN   | Pack 2 Powder |
|--------------------------|--|---------------|
| <b>Hazard Pictograms</b> |  |               |
| <b>Signal Word</b>       | : Danger   |               |
| <b>Hazard Statements</b> | : H226 Flammable liquid and vapour<br>H332 Harmful if inhaled<br>H315 Causes skin irritation<br>H319 Causes serious eye irritation<br>H335 May cause respiratory irritation<br>H372i Causes damage to organs through prolonged or repeated exposure if inhaled<br>H400: Very toxic to aquatic life |               |



MATERIAL SAFETY  
DATA SHEET

MSDS Revision da  
01/02/201

**Precautionary statements**

**Prevention**

- S15 Keep away from heat, sparks, open flames & hot surfaces
- S16 Keep away from sources of ignition - No smoking
- S17 Keep away from combustible material
- S37/39 Wear suitable gloves and eye/face protection
- P261: Avoid breathing dust/fume/gas/mist/vapours/spray
- P273: Avoid release to the environment
- P272: Contaminated work clothing should not be allowed out of the workplace

**Response**

- P304+340: IF INHALED: Remove victim to fresh air and keep at rest in a position comfortable for breathing
- P303+361+353: IF ON SKIN (or hair): Remove/Take off immediately all contaminated clothing. Rinse skin with water/shower
- P333+313: If skin irritation or a rash occurs: Get medical advice/attention
- P305+351+338: IF IN EYES: Rinse cautiously with water for several minutes. Remove contact lenses if present and easy to do - continue rinsing
- P337+313: If eye irritation persists get medical advice/attention
- P264: Wash hands and contaminated skin thoroughly after handling
- P272: Contaminated work clothing should not be allowed out of the workplace
- P280: Wear protective gloves, protective clothing, eye protection, face protection
- P302+352: IF ON SKIN: Wash with soap and water
- P308+313: IF exposed or concerned: Get medical advice/attention
- P391 : Collect spillage

**Storage**

- S3/9/49 Keep only in the original container in a cool, well-ventilated place

**Disposal**

- P501: Dispose of contents & container according to local regulations

**Hazardous Ingredients**

- Styrene

3

**Other Hazards**

**Other Hazards which do not result in classification**

- Pure silica sand within the powder mixture is not regarded as a health or environmental hazard under current legislation

**SECTION 3 COMPOSITION/INFORMATION ON INGREDIENTS**

Definition		Mixture	
Product/Ingredient Name	Identifiers	% Content	Classification 67/548/EEC Regulation(EC) No. 1272/2008 (CLP)
Styrene	REACH #: 01-2119457861-32 EC: 202-851-5 CAS: 100-42-5 Index: 601-026-00-0	35-50	R10 Xn; R20,R48/20, R65 Xi; R36/37/38 Flam Liq. 3. H226 Acute Tox. 4 H332 Skin Irrit. 2. H315 Eye Irrit. 2. H319 STOT SE 3. H335 STOT RE 1 H372i Asp. Tox. 1. H304
1-naphthquinone	EC: 204-617-8 CAS: 123-31-9 Index: 604-005-00-4	<0.1	Carc. Cat. 3; R40 Muta. Cat. 3; R68 Xn: R22 Xi R41 R43 N; R50 Acute Tox. 4; H302 Eye Dam. 1; H318 Skin Sens. 1; H317 Muta. 2; H341 Carc. 2; H351 Aquatic Acute 1; H400
benzoylperoxide, 20% Powder with inert fillers (Stated below)	EC: 202-327-6 CAS: 000094-36-0	<1%	EN Xi R03, R36, R43, R50/53 Expl. Fire. 2; H241 Skin Sens. 1; H317 Eye Irrit. 2; H319 Aquatic acute. 1; H400
Barium Sulphate	EC: 231-900-3 CAS: 007778-18-9		None
Magnesium Carbonate Hydroxide	EC: 235-192-7, 231-851-8 CAS: 012125-28-9, 007760-50-1		None
			See section 16 for the full text of the R- See section for the full text of the H statements

# Material Safety Data Sheet MSDS

Complies with OSHA Hazard Communication Standard  
29 CFR 1910.1200



MATERIAL SAFETY  
DATA SHEET

MSDS Revision date  
01/02/2012

---

There are no additional ingredients present which, within the current knowledge of the supplier and in the concentrations applicable, are classified as hazardous to health or the environment and hence require reporting in this section.

Occupational Exposure Limits, if available, are listed in Section 8.



MATERIAL SAFETY  
DATA SHEET

MSDS Revision date  
01/02/2012

**SECTION 4: FIRST AID MEASURES**

- 4.1 Description of First aid Measures**
- Eye contact** : Immediately flush eyes with plenty of water, occasionally lifting the upper and lower eyelids. Check for and remove contact lenses. Continue to rinse for at least 10 minutes. Get medical attention.
- Inhalation** : Remove victim to fresh air and keep at rest in a position comfortable for breathing. Maintain an open airway. Loosen tight clothing such as collar, tie, belt or waistband.
- Skin Contact** : Flush contaminated skin with plenty of water. Remove contaminated clothing and shoes. Continue to rinse for at least 10 minutes. Get medical attention. Wash clothing before re-use. Clean shoes thoroughly before re-use.
- Ingestion** : Wash out mouth with water. Remove dentures if fitted. Remove victim to fresh air and keep at rest in a position comfortable for breathing. Stop if the exposed person feels sick, as vomiting may be dangerous. Do not induce vomiting unless directed to do so by medical personnel. If vomiting occurs, the head should be kept low so that vomit does not enter the lungs. Get Medical attention following exposure or if feeling unwell. Never give anything by mouth to an unconscious person. If unconscious, place in recovery position and get medical attention immediately. Loosen tight clothing such as collar, tie, belt or waistband.
- Protection of First Aiders** : No action will be taken involving any personal risk or without suitable training.
- 4.2 Most important symptoms and effects, both acute and delayed**
- Potential acute health effects**
- Eye contact** : Causes serious eye irritation
- Inhalation** : Harmful if inhaled
- Skin Contact** : Causes skin irritation
- Ingestion** : Irritating to mouth, throat and stomach
- Over-exposure signs / symptoms**
- Eye contact** : Adverse symptoms may include the following:  
Pain or irritation  
Watering  
Redness
- Inhalation** : Adverse symptoms may include the following:  
Respiratory tract irritation  
Coughing
- Skin Contact** : Adverse symptoms may include the following:  
Irritation  
Redness
- Ingestion** : No specific Data
- 4.3 Indication of any immediate medical attention and special treatment needed**
- Notes to Physician** : Treat symptomatically. Contact poison treatment specialist immediately if large quantities have been ingested or inhaled.
- Specific Treatments** : No specific Treatment

**SECTION 5: FIREFIGHTING MEASURES**

- 5.1 Extinguishing Media**
- Small fire**
- Suitable** : Use dry chemical powder, CO2 or alcohol resistant foam. Cover with vermiculite or other non combustible material.
- Not Suitable** : Do not use water jet
- Large Fire**
- Suitable** : Alcohol resistant foam
- Not Suitable** : Do not use water jet
- 5.2 Special hazards arising from the mixture**
- Hazards from the mixture** : Flammable liquid and /or vapour. In a fire or if heated, a pressure increase will occur and the container may burst, with the risk of a subsequent explosion. Runoff to sewer may create fire or explosion hazard.
- Hazardous combustion products** : In case of fire, may produce hazardous decomposition products such as carbon monoxide, carbon dioxide, dense black smoke, aldehydes, organic acids.
- 5.3 Advice for firefighters**
- Special precautions for fire fighters** : Fire water contaminated with this material must be prevented from entering waterways, sewers or drains.
- Special protective equipment for firefighters** : Fire-fighters should wear appropriate protective equipment and self contained breathing apparatus (SCBA) with a full face piece operated in positive pressure mode. Clothing for fire fighters (including helmets, protective boots and gloves) conforming to European standard EN469 will provide a basic level of protection for chemical incidents.

# Material Safety Data Sheet

## MSDS

Complies with OSHA Hazard Communication Standard  
29 CFR 1910.1200

# Crosby®



MATERIAL SAFETY  
DATA SHEET

MSDS Revision date  
01/02/2012

### SECTION 6: ACCIDENTAL RELEASE MEASURES.

- 6.1** Personal precautions, protective equipment and emergency procedures (LARGE SPILLS ONLY)
- 6.2** Environmental precautions : Avoid dispersal of spill material, run-off and contact with soil, waterways, drains and sewers.
- 6.3** Methods and materials for containment and cleaning up
- Small spill** : Stop leak if without risk. Move containers from the spill area. Absorb with an inert dry material and place in an appropriate waste disposal container.  
Dispose of using a licensed waste disposal contractor.
- 6.4** References to other sections : See section 1 for contact information  
See section 8 for information on appropriate PPE  
See section 13 for additional waste treatment information.

### SECTION 7: HANDLING & STORAGE

- 7.1** Precautions for safe handling
- Protective measures** : Wear appropriate PPE, (See Section 8). Do not breathe vapour. Do not ingest. Avoid contact with eyes, skin & clothing. Use only with adequate ventilation. Always keep in the original container. Store and use away from heat and ignition sources. Do not reuse the containers.
- Advice on General Hygiene** : Eating, drinking and smoking should be prohibited in areas where this material is handled, stored and processed. Workers should wash hands before eating drinking and smoking. Remove contaminated clothing and PPE before entering eating areas. See Section 8 for additional information on Hygiene measures.
- 7.2** Conditions for safe storage including incompatibilities : Do not store above 20 degrees C, 68 degrees F. Store in accordance with local regulations. Store in a segregated and approved area. Store the original container protected from direct sunlight in a dry, cool and well ventilated area, away from incompatible materials, food & Drink. Eliminate all ignition sources. Separate from oxidizing materials. Do not store in unlabelled containers. Use appropriate containment to avoid environmental contamination.

### SECTION 8: EXPOSURE CONTROLS/ PERSONAL PROTECTION

The information in this section contains generic advice and guidance. The list of identified uses in Section 1 should be consulted for any available use specific information provided in the Exposure Scenario.

**8.1** Control Parameters  
Occupational exposure limits

Styrene	EH40/2005 WELS (United Kingdom) 8/2007 STEL : 250 ppm @ 15 minutes TWA : 100 ppm @ 8 hours TWA : 430 mg/m <sup>3</sup> @ 8 hours STEL : 1080 mg/m <sup>3</sup> @ 15 minutes
1,4 naphthquinone	EH40/2005 WELS (United Kingdom) 8/2007 TWA : 0.5 mg/m <sup>3</sup> @ 8 hours
Dibenzoylperoxide,	EH40/2005 WELS (United Kingdom) 8/2007 TWA : 5 mg/m <sup>3</sup> @ 8 hours

**Recommended Monitoring procedures** : This product contains ingredients with exposure limits, therefore, personal, workplace atmosphere or biological monitoring may be required to determine the effectiveness of the ventilation or other control measures and/or the necessity to use respiratory protective equipment. Reference should be made to European Standard EN 689 for methods for the assessment of exposure by inhalation to chemical agents and national guidance documents for the methods for the the determining of hazardous substances.

Derived effect levels

Product /ingredient name	Type	Exposure	Value	Population
Styrene	DNEL	Short term inhalation	289 mg/m <sup>3</sup>	Workers
	DNEL	Short term inhalation	306 mg/m <sup>3</sup>	Workers
	DNEL	Long term inhalation	85 mg/m <sup>3</sup>	Workers

Predicted effect concentrations

Product /ingredient name	Type	Compartment Detail	Value	Method Detail
Styrene	PNEC	Fresh water	0.028 mg/l	Assessment factors
	PNEC	Marine	0.0028 mg/l	Assessment factors
	PNEC	Fresh water sediment	0.614 mg/kg dwt	-
	PNEC	Marine water sediment	0.0614 mg/kg dwt	-
	PNEC	Sewage treatment plant	5 mg/l	Assessment factors
	PNEC	Soil	0.2 mg/kg dwt	-



MATERIAL SAFETY  
DATA SHEET

MSDS Revision date  
01/02/2012

**8.2 Exposure Controls**  
Appropriate Engineering Controls : Use only with adequate ventilation.

**Individual Protection measures**

Hygiene measures : Wash hands, forearms and face thoroughly after handling chemical products, before eating smoking and using the lavatory and at the end of each working period. Appropriate techniques should be used to remove potentially contaminated clothing. Wash contaminated clothing before reuse. Ensure that eyewash stations are close to the work location.

Eye/face protection : Safety glasses with side protection.

Hand protection : 8 hours breakthrough time : Fluor rubber (Viton) (0.70mm)  
>1 hour breakthrough time : Chloroprene, Nitrile rubber (0.2mm)

Skin & Body : Wear suitable protective clothing

Respiratory protection : Wear filter mask, filter type A.

Advice on personal protection is applicable for high exposure levels. Select proper PPE based on a risk assessment of the actual exposure level.

**SECTION 9 : PHYSICAL AND CHEMICAL PROPERTIES**

**9.1 Information on basic physical & chemical properties (Resin)**

Physical State : Liquid  
Colour : Pale Yellow  
Odour : Characteristic  
Odour threshold : Not available  
pH : Not available  
Melting point : Not available  
Initial boiling point and boiling range : 145 degrees C  
Softening range : Not available  
Flash point : 31 degrees C  
Evaporation rate : Not available  
Flammability, Burning time, Burning Rate : Not available  
Upper/lower flammability or explosive limits : Not available  
Vapour pressure : Not available  
Vapour density : Not available  
Relative density : 1.09 (water = 1)  
Density (g/cm<sup>3</sup>) : 1.09 g/cm<sup>3</sup> (25 degrees C)  
Bulk density : Not available  
Solubility : Insoluble in cold water  
Solubility in water : Not available  
Solubility at room temperature : Not available  
Partition co-efficient: n-octanol/water : Not available  
Auto ignition temperature : Not available  
Decomposition temperature : Not available  
Viscosity : Dynamic : 335 to 455 mPa's (335 to 455 cP)  
Explosive properties : Not available  
Oxidising Properties : Not available

**9.2 Information on basic physical & chemical properties (Dibenzoyl peroxide)**

Appearance : Free flowing powder  
Colour : White  
Odour : Faint  
Boiling Point range : Not applicable ( Decomposes)

# Material Safety Data Sheet

## MSDS

Complies with OSHA Hazard Communication Standard  
29 CFR 1910.1200

# Crosby®



MATERIAL SAFETY  
DATA SHEET

MSDS Revision date  
01/02/2012

Melting point range	:	Not Determined
Flash point	:	Not applicable
Flammability	:	Decomposition products may be flammable
Explosive properties	:	None
Oxidising Properties	:	Not Applicable
Vapour pressure	:	Not Applicable
Density (g/cm <sup>3</sup> )	:	2290 kg/m <sup>3</sup> (20 degrees C / 68 degrees F) Specific gravity = 2.29 (20 degrees C / 68 degrees F)
Bulk density	:	588 kg/m <sup>3</sup> (20 degrees C / 68 degrees F)
Solubility in water	:	Insoluble
Solubility in other solvents	:	Not Determined
pH	:	Neutral
Partition co-efficient: n-octanol/water	:	Not Determined
Vapour density	:	Not Applicable
Viscosity	:	Not Applicable
Active oxygen content	:	1.32%
Peroxide content	:	20%
Auto Ignition temperature	:	Test Method not applicable (see section 10)
SADT	:	70 degrees C (See section 10)
Explosion limits	:	Not Determined
Volatile %	:	Not Determined

### SECTION 10 : STABILITY & REACTIVITY

10.1	Reactivity (RESINS)	:	No specific test data related to reactivity for this product or ingredients
10.2	Reactivity (POWDER)	:	No specific test data related to reactivity for this product or ingredients
10.3	Chemical stability (RESIN)	:	The product is stable
10.4	Chemical stability (POWDER)	:	SADT- (Self accelerating decomposition temperature) is the lowest temperature at which self accelerating decomposition may occur with a substance in the packaging used in transport. A dangerous self-accelerating decomposition reaction, which could result in explosion or fire above 70 degrees C. Contact with oxidising agents can cause decomposition below 70 degrees C. Containers must be sealed at all times when not in use.
10.5	Possibility of hazardous reactions (RESIN)	:	Under normal storage conditions, hazardous reactions will not occur
10.6	Possibility of hazardous reactions (POWDER)	:	Under normal storage conditions, hazardous reactions will not occur
10.7	Conditions to Avoid (RESIN)	:	Avoid all sources of ignition. Do not pressurize, cut, weld, braze, solder, drill, grind or expose containers to heat sources.
10.8	Conditions to Avoid (POWDER)	:	Avoid shock and friction. A high degree of confinement should be avoided.
10.9	Incompatible materials (POWDER)	:	Avoid contact with rust, iron and copper. Contact with incompatible materials such as acids, alkalis, heavy metals & reducing agents will result in hazardous decomposition. Do not mix with accelerators.
10.1	Hazardous decomposition products (RESIN)	:	No specific data.
10.11	Hazardous decomposition products (POWDER)	:	Benzoic acids, benzene
10.12	Polymerisation (POWDER)	:	Does not occur

### SECTION 11 : TOXICOLOGICAL INFORMATION

#### 11.1 Information of Toxicological Effects

Product/Ingredient Name	Result	Species	Dose	Exposure
Styrene	LD50 Dermal	Rat	>2000 mg/kg	-
	LD50 Oral	Rat	5000 mg/kg	-
	LC50 Inhalation	Rat	12 g/m <sup>3</sup>	4 hours
	Vapour			
1,4 naphthoquinone	LC50 Inhalation dusts and mists	Rat	46 mg/m <sup>3</sup>	4 hours
	LD50 Dermal	Rat	202 mg/kg	-
	LD50 Oral	Rat	190 mg/kg	-
Dibenzoylperoxide 78%	LD50 Oral	Rat	5000 mg/kg	-
	LC50 Inhalation	Rat	24.3 mg/l	4 hours

Note: No toxicological information on the Dibenzoyl peroxide was available at 20%. The above test was carried out at 78%

#### Acute Toxicity estimates (RESIN)

Route	ATE Value
Inhalation (Gases)	15397.5 ppm
Inhalation (Vapours)	37.64 mg/l
Inhalation (Dusts and mists)	5.133 mg/l



MATERIAL SAFETY  
DATA SHEET

MSDS Revision date  
01/02/2012

Function  
Skin  
Eyes  
Respiratory  
Sensitization  
Genotoxicity  
Carcinogenicity  
Teratogenicity

Irritation / corrosion

Resin  
Not Available  
Not Available  
Not Available  
Not Available  
Not Available  
Not Available  
Not Available

Powder  
None at 4 hours exposure time  
Moderate  
None  
Possible by skin contact.  
Ames test --- None  
Not available  
Not available

Specific Target organ Toxicity (Single exposure)

Product / Ingredient name	Category	Route of Exposure	Target Organs
Styrene	Category 3	Not Determined	Respiratory tract irritation
1,4 naphthoquinone	Category 3	Not Determined	Respiratory tract irritation

Specific Target organ Toxicity (Repeated exposure)

Product/ingredient name	Category	Route of Exposure	Target Organs
Styrene	Category 1	Inhalation	Ears

Potential acute health effects

- Inhalation : Harmful if inhaled. May cause respiratory irritation
- Ingestion : Irritating to mouth, throat & stomach
- Skin contact : Causes skin irritation
- Eye Contact : Causes serious eye irritation

Symptoms related to the physical, chemical and toxicological characteristics

- Inhalation : Adverse symptoms may include the following:  
Respiratory Tract irritation  
coughing
- Ingestion : No specific data
- Skin contact : Adverse symptoms may include the following:  
Irritation  
Redness
- Eye Contact : Adverse symptoms may include the following:  
Pain or irritation  
Watering  
Redness
- General : Causes damage to organs through prolonged or repeated exposure if inhaled.
- Carcinogenicity : No known effects or critical hazards
- Mutagenicity : No known effects or critical hazards
- Teratogenicity : No known effects or critical hazards
- Developmental effects : No known effects or critical hazards
- Fertility effects : No known effects or critical hazards

Classification

Product / Ingredient name	ACGIH	IARC	EPA	NIOSH	NTP	OSHA
Styrene	A4	2B	-	-	-	-
1,4 naphthoquinone	A3	3	-	-	-	-

SECTION 12: ECOLOGICAL INFORMATION

12.1 Toxicity				
Product/ingredient name	Result	Species	Exposure	Effects
Styrene	Acute EC50 4.9 mg/l	Algae	72 hours	-
	Acute LC50 4.02 mg/l	Fish - Fathead minnow	96 hours	-
	Chronic NOEC 1.01 mg/l	Daphnia - Daphnia magna	21 days	-
1,4 naphthoquinone	EC50 0.011mg/l	Algae	72 hours	-
Dibenzoylperoxide 78%	Acute EC50 2.91 mg/L Fresh water	Daphnia	48 hours	-
	Acute LC50 2.0 mg/l	Poecilia reticulata	96 hours	-
	Acute EC50 - activated sludge respiration inhibition test 35 mg/l	Bacteria		-

12.2 Persistence and degradability

Product / Ingredient name	Aquatic half life	Photolysis	Biodegradability
Styrene	-	-	Readily
Dibenzoylperoxide 78%	-	-	Readily

# Material Safety Data Sheet

## MSDS

Complies with OSHA Hazard Communication Standard  
29 CFR 1910.1200



MATERIAL SAFETY  
DATA SHEET

MSDS Revision date  
01/02/2012

### 12.3 Bioaccumulative potential

Product / Ingredient name	Log P	BCF	Potential
Styrene	2.95		Low
1.4 naphthoquinone	1.71		Low
Dibenzoylperoxide 78%	-		

### 12.4 Mobility in soil

Soil/water partition coefficient (Koc)	: Not available
Mobility	: Not available

### 12.5 Results of PBT and vPvB assessment

PBT	: Not applicable
vPvB	: Not applicable

### 12.6 Other adverse effects

No known significant effects or critical hazards.

## SECTION 13: DISPOSAL CONSIDERATIONS

The information in this section contains generic advice and guidance. The list of identified uses in section 1 should be consulted for any available use-specific information provided in Exposure scenarios.

### 13.1 Waste Treatment Methods

#### Product

- Methods of disposal**
- The generation of waste should be avoided or minimised wherever possible. Empty containers may retain some of the product residue. The container must be disposed of in a safe way. Dispose of surplus and non-recyclable products via a licensed waste disposal contractor. Disposal of the product, solutions and by-products should at all times comply with the requirements of the environmental protection and waste disposal legislation and any regional local authority requirements. Avoid dispersal of spilt material and contact with soil, waterways, drains and sewers.
- Hazardous waste**
- The classification of the product may meet criteria for hazardous waste.



#### Packaging

- Methods of disposal**
- The generation of waste should be avoided or minimised wherever possible. Waste packaging should be recycled. Incineration or landfill should only be considered when recycling is not feasible.

#### Special precautions

- This material and its containers must be disposed of in a safe way. Care should be taken when handling emptied containers that have not been cleaned and rinsed out. Empty containers may contain product residue. Vapour from the residue may create a highly flammable or explosive atmosphere within the container. Do not cut, weld or grind the container unless they have been cleaned thoroughly. Avoid dispersal of spilt material and contact with soil, waterways, drains and sewers.

## SECTION 14: TRANSPORT INFORMATION

	UN3269	UN1866
14.1 UN Number	UN3269	UN1866
14.2 UN Proper Shipping name	Polyester Kit	Bulk Resin
14.3 Transport hazard Class		
14.4 Packing Group	III	III
14.5 Environmental Hazards	No	No
14.6 Special precautions for the end user	Not available	Not Available
Additional Information	Flashpoint 31 degrees C	Flashpoint 31 degrees C



MATERIAL SAFETY  
DATA SHEET

MSDS Revision date  
01/02/2012

SECTION 15: REGULATORY INFORMATION

15.1 Safety, health & environmental regulations/legislation specific for the mixture.

EU Regulation (EC) No. 1907/2006 (REACH)

Annex XIV - List of substances subject to authorisation

Substances of very high concern

None of the components are listed

Annex XVII - Restrictions on the manufacture, placing on the market and use of dangerous substances, mixtures and articles.

Not Applicable

15.2 Chemical safety Assessment : Not applicable

SECTION 16: OTHER INFORMATION

Procedure used to derive the classification according to regulation (EC) No 1272/2008 [CLP/GHS]

Classification	Justification
Flam Liq. 3, H226	On basis of test data
Acute Tox. 4, H332	Calculation methods
Skin Irrit. 2 H315	Calculation methods
Eye Irrit. 2, H319	Calculation methods
STOT SE 3, H335	Calculation methods
STOT RE, H372i	Calculation methods

Full text of abbreviated H Statements	H226 H302 H315 H317 H318 H319 H332 H335 H372i H400	Flammable liquid & vapour Harmful if swallowed Causes skin irritation May cause allergic skin reaction Causes serious eye damage Causes serious eye irritation Harmful if inhaled May cause respiratory irritation Causes damage to organs through prolonged or repeated exposure if inhaled. Very toxic to aquatic life
Full text of classifications [CLP/GHS]	Acute Tox 4, H302 Acute tox 4, H332 Aquatic Acute 1, H400 Eye Dam. 1, H318 Eye Irrit. 2, H319 Flam. Liq. 3, H226 Skin Irrit. 2, H315 Skin Sens. 1, H317	ACUTE TOXICITY: ORAL - Category 4 ACUTE TOXICITY : INHALATION - Category 4 AQUATIC TOXICITY (ACUTE) Category 1 SERIOUS EYE DAMAGE / EYE IRRITATION Category 1 SERIOUS EYE DAMAGE / EYE IRRITATION Category 2 FLAMMABLE LIQUIDS - Category 3 SKIN CORROSION/IRRITATION - Category 2 SKIN SENSITIZATION - Category 1
Abbreviations and Acronyms	ATE CLP DNEL EUH PNEC RRN	Acute Toxicity Estimate Classification, Labelling & Packaging Regulation [Regulation (EC) No. 1272/2008] Derived No Effect Level (Statement) CLP Specific Hazard Statement Predicted No Effect Concentration REACH Registration Number

Sources of Key data Information derived from investigations and literature from raw material suppliers

Training Advice Handling and preparation of the product to be carried out by competent personnel only.

**Notice to Reader**

The information contained in the Safety Data Sheet is based on data available at the time of publication. The information is intended to aid the user in controlling the handling risks and is not to be construed as a warranty or specification of the product quality. The information may not be or may not altogether be applicable to combinations of the kit with other substances or to particular applications.

The user is responsible for ensuring that appropriate precautions are taken and for satisfying themselves that the data is suitable and sufficient for the product's intended purpose. In case of any unclarity we advise consulting the supplier or an expert.

# Resin Socketing of Steel Wire Rope

## Appendix B Resin Socketing of Steel Wire Rope

J.M. Dodd B.Sc

Millfield Enterprises

16 Shelley Road, Newburn Industrial Estate, Newburn  
Newcastle upon Tyne, NE15 9RT, England

The concept is not new. The first published data on this topic were produced in the early sixties. In essence, these two papers by Doherty and Campbell, stated that a resin filled socket under either static tension (tensile) or fluctuating tension (fatigue) could offer strengths that were comparable with those of the rope itself.

There is a dearth of information on socketing and the mechanisms by which it works, so it was necessary to establish some basic knowledge before a resin socketing system could be designed.

In theory, the requirements for a successful system are:-

- 1) High bond strength between resin and wire
- 2) High modulus of elasticity

To ascertain the bond strength and the magnitude of the predicted frictional grip, tests were done on a single, straight wire cast into a cylindrical block of resin. The embedded length being such, that the wire when loaded would slip rather than break. The cylindrical resin termination was chosen so that there would be no distortion of the figures, due to the mechanical lock, inherent in a conical termination. The results are shown in Figure 1.

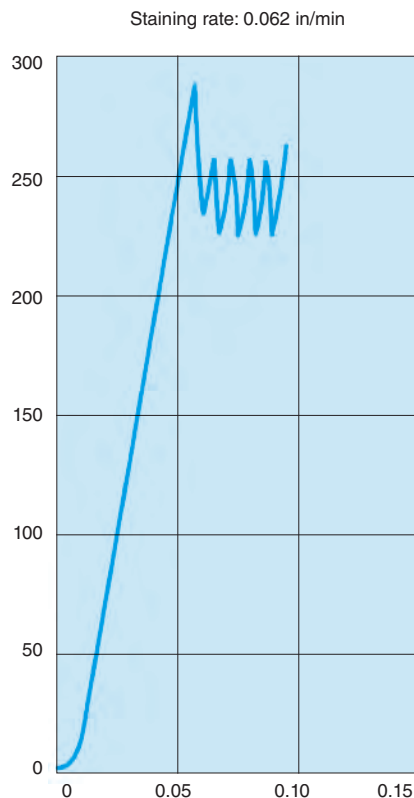

**Fig 1**  
Pull out characteristic for single wire embedded in polyester resin/silica

# Resin Socketing of Steel Wire Rope

The graph shows that high bond strengths are achievable between the resin and the wire and that shrinkage of the resin and the inclusion of hard silica in the resin gave a very high frictional grip on the wire. The classic slip/grip peaks and troughs on the right hand side of the loading curve show that the frictional grip is very nearly of the same magnitude as the bond strength.

In practice, it has been found that the wires in the rope broom, which is about to be socketed, are rarely clean enough to achieve anything approaching a good bond strength. Indeed, it will be shown later, when dealing with uncleaned wires, that the frictional grip alone is enough to seat the cone. Either the bond strength of the resin to the wire or the frictional grip of the resin on the wire, is sufficient on their own to seat the cone. Between them they offer a comforting reassurance that the wire will hold and the cone will seat even if the wire has not been cleaned properly.

The modulus of elasticity was measured and found to be 6085 Mpa (BS63 19 Part 6, 1984).

It very soon became apparent, that the bonding action between the socketing medium and the wire was not in itself sufficient to break the rope. Therefore the focus was moved to the shape of the socket, the wedging action it would produce and the mechanism by which this occurred.

The usual total included angle in sockets is between 14/15 degrees and experiments were carried out over the range 9/25 degrees total included angle. It was predicted that the narrower the angle, the lower the load at which movement occurred and the greater that movement would be. In general, this prediction was confirmed, although in the case of the lower angles, the straight line relationship experienced on the wider angles was not found. See Figure II In all cases, the rope ultimately broke, this confirms that the system will cope with a fairly wide deviation from standard socket dimensions.

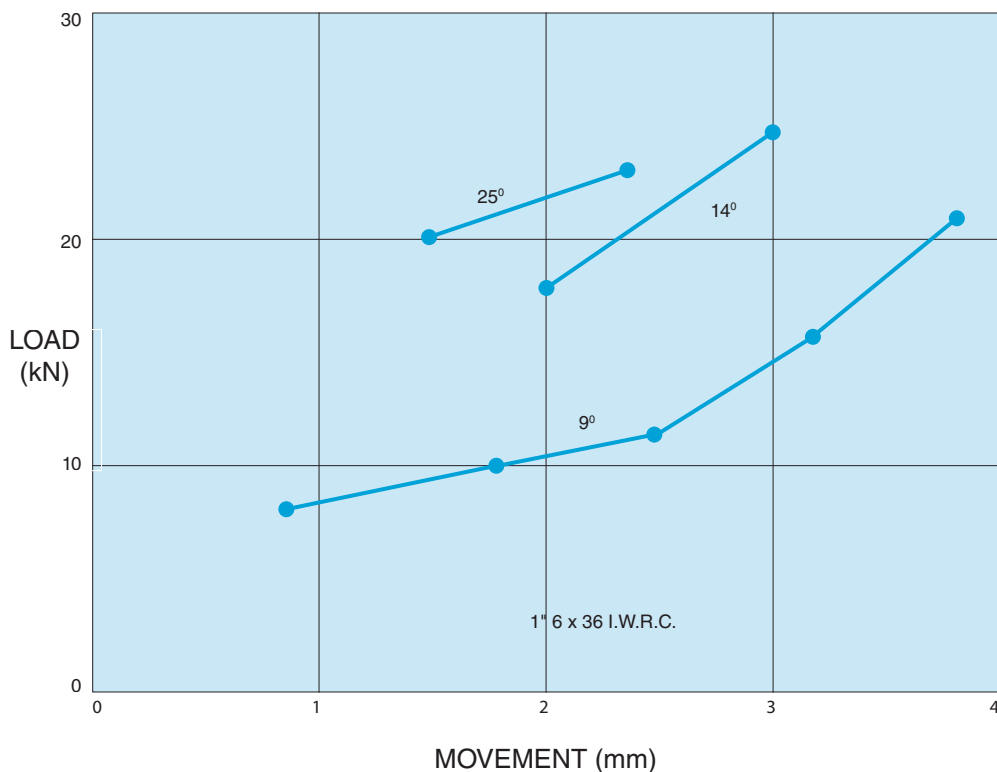

**Fig II**  
**Movement within the socket under load for the two extreme angles and the standard 140 taper**

# Resin Socketing of Steel Wire Rope

The mechanism of this movement and wedging action were investigated by looking at the distribution of pressure through the socket. This showed that approximately two thirds of the total pressure within the socket was concentrated in the bottom third of the socket. Whilst pressure at the top of the socket was very low indeed.

It is necessary to explain why any movement is possible within the socket and to link it with the pressure distribution findings above.

When the resin is first poured into the socket there is a perfect match between the shape of the socket and the resin cone. Once the resin has cured, however, shrinkage occurs and in an exaggerated form the effect is as below. (Fig III)

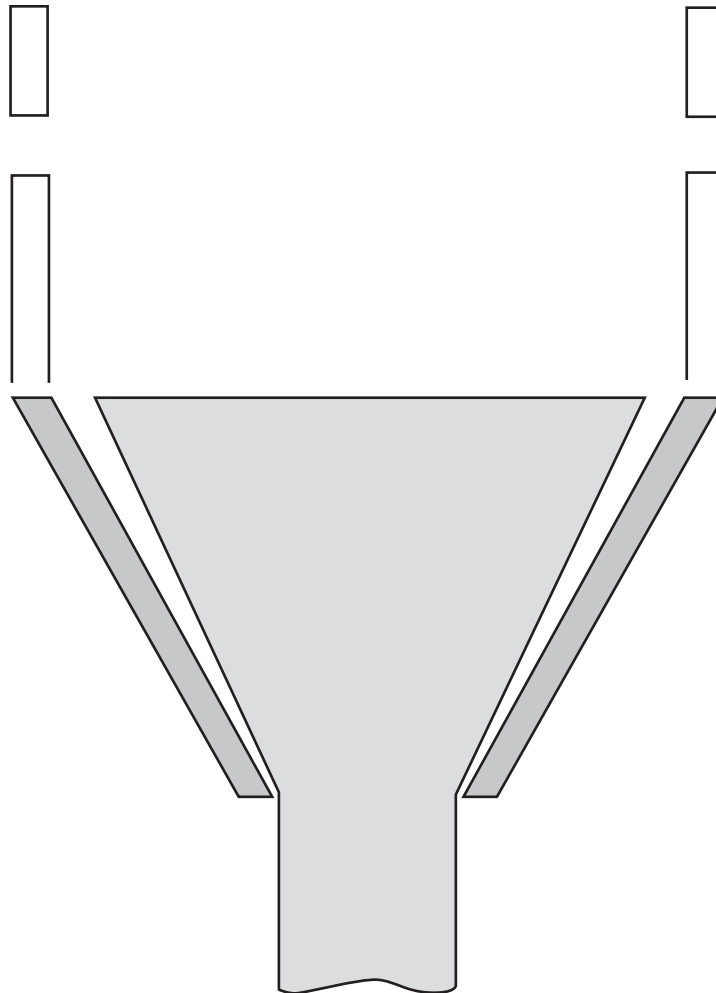

**Exaggerated Relationship between Cone and Socket after the Resin has cured**  
**Figure III**

When the load is applied to the rope, any adhesion of the resin to the socket will shear and the cone, which is now slightly smaller, will begin to engage the socket wall at the neck of the socket, thereby generating pressure. Although it still retains a high modulus, the resin in contact with the socket is subject to plastic deformation and some flow is possible, allowing more of the cone to share in the loading process. This participation in load bearing diminishes as we proceed up the cone. See figures IV & V.

# Resin Socketing of Steel Wire Rope

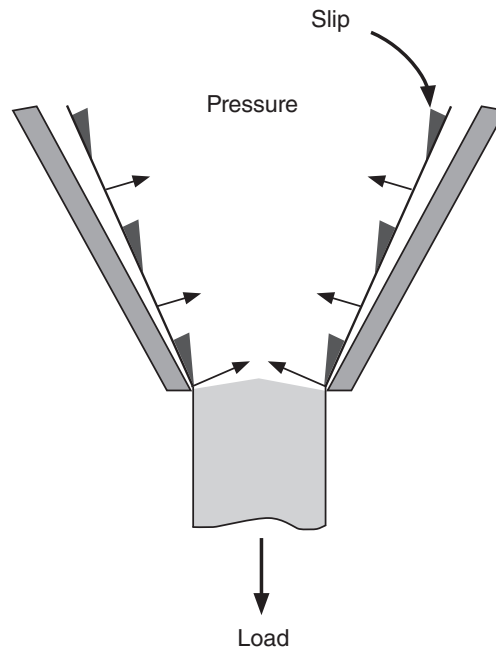

Load causes the cone to slip at the socket interface and the pressure generated locks the cone within the socket

Fig IV

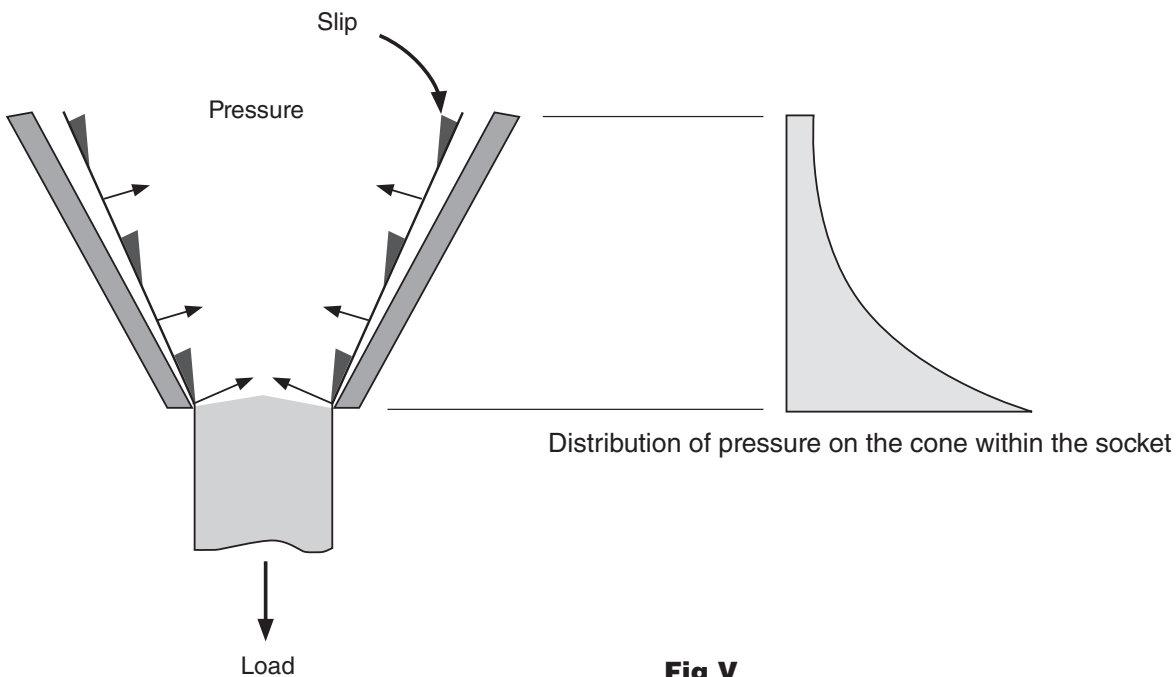

Fig V

If we examine the forces present in Fig IV, we can see that when load is applied, the cone will seat progressively generating forces normal to the socket face. These forces are transmitted through the resin to the wire surface. We are, in effect, creating a wire reinforced composite wedge on the end of the rope, which is capable of withstanding the ultimate strength of the rope.

# Resin Socketing of Steel Wire Rope

We now have to consider two different scenarios to establish the key to this mechanism. In the first case, when the load is applied, the wire slips at the resin/wire interface before the cone slips at the cone/socket interface. In the second case upon application of the load the cone slips in the socket/resin interface before the wire slips within the resin.

In the first case, we have a disaster, as the rope will pull out. In the second case we have success, as the rope will break. What is it that determines which will occur?

Assuming that the coefficient of friction between the wire and the resin and the resin and the socket are of the same order, (an over simplification, but it does produce a simple model), the factor that determines which of the above scenarios will occur is the relationship between the surface area of the wire (S1) and the surface area of the inside of the cone (S2). If S1 is greater than S2 then the cone will seat and the rope will break. If S2 is greater than S1 the assembly will fail.

If, for example, we take a 13mm diameter 6 x 19 IWRC rope the relationship between S1 and S2 is of the order of 6:1, for a 36mm diameter 6 x 36 IWRC 9:1 and for a 52mm diameter 6 x 41 IWRC 10:1. These figures give an indication of the margins of safety involved when resin socketing is employed. It also shows that the degreasing would have to be disastrously bad to reduce the coefficient of friction at the wire/resin interface to a critical level. One factor that has been ignored in this simple model, is that the unstraightened wires in the broom produce deformation forces when any attempt is made to induce slip thus increasing the grip of the resin on the wire and giving a further factor of safety. This wire in the cast cone, also tends to prevent any significant degree of axial extension of the cone during loading and the cone remains almost a constant length.

It would be useful at this point to examine the Federal Specification socket which has grooves or rings internally. It is obvious, that these rings must shear before the "locking" mechanism can operate and as such, are a hindrance to that process. Incidentally, in the case of zinc and white metal, this rupturing of the rings is also required before the rope will break. The only justification for these rings is to stop the cone "backing out" of the socket. In fact, once "seating" of the cone within the socket has occurred, it is not reversible and the cone is then locked into position.

This irreversibility offers the bonus that the stresses created within the socket are fixed and because there is no fluctuation, it follows that the opportunities for fatigue within the socket are reduced.

Let us return to the question of clean and uncleaned wire. A series of tests were carried out by A.I.F. in France, in which two samples of each of a series of rope sizes and constructions were broomed. One sample was degreased with trichlorethane and the other sample was left uncleaned.

Both samples went on to achieve the full breaking strength of the rope and almost identical breaking loads were achieved.

This highlights the fact that the frictional grip on the wires is highly efficient. If we take an overview of the whole situation it becomes apparent that the key operation in the resin socketing process is the brooming of the rope. Indeed this operation is vital for zinc and white metal as well.

Surface area of wire is vital, especially in the highly loaded section at the neck of the socket. From a quality point of view the broom should be opened right down to the seizing. Very often we see brooms which look very pretty and are nicely opened at the top but the strands remain substantially closed near the seizing. This state of affairs does not produce a quality assembly, even though it may break the rope.

One further point on the production of a quality assembly, is that care should be taken to ensure that the neck of the socket has been sealed with clay or putty. Any leaks could cause voids in the neck area of the socket. These voids are able to form because the resin starts to gel - harden - in the centre of the mass and if resin leaks out at the neck of the socket, the resin above it during gel is no longer liquid and is, therefore, unable to flow down to fill the void.

# Resin Socketing of Steel Wire Rope

It is not necessary to hook wires when resin socketing except in the case of coarse construction wire rope such as 6 x 7.

In use, the resin socketed assembly offers a higher achievable tensile strength and a better fatigue performance of the assembly. In general, this can be attributed to two factors; the excellent penetration of resin, ensuring a complete cone and, secondly, the fact that there is no annealing of the wires due to heat from molten metal. A further benefit that is derived from the lack of heat, is that the lubricant in the rope remains intact and is not burned off. It is an easy matter to replace the lubricant on the outside of the rope but very difficult to replace the lubricant in the centre of the rope. It is, as it does not require any heat, acid etching or neutralising, an inherently safe method, for the rigger to use both in the shop and on site. Finally, the quality and reliability of this method is, without question, superior to other methods of socketing. It also avoids the damage caused to ropes by other mechanical methods of attachment of end fittings, which may affect both the tensile and fatigue potential.

## Bibliography

Dodd J.M.	Resin As A Socketing Medium	Wire Industry	- May 1981
Chaplin Dr C.R. Sharman P.C.	Load Transfer Mechanics in Resin Socketing	Wire Industry	- Oct 1984
Cordon Dr C.R.R.	The Use Of Resin For Man Riding In Mine Shafts	IMEMME	- March 1987



**GENERAL OFFICES**  
2801 DAWSON ROAD  
Tulsa < OK 74110  
P: (918) 834-4611  
F: (918) 832-0940  
[www.thecrosbygroup.com](http://www.thecrosbygroup.com)  
[crosbygroup@thecrosbygroup.com](mailto:crosbygroup@thecrosbygroup.com)

August 2, 1993

# TECHNICAL DATA SHEET

## REUSE OF CROSBY SPELTER SOCKETS

The following are general guidelines for the reuse of Crosby 416/417 Spelter Sockets. The use and inspection of used spelter sockets is the responsibility of the user.

### I. Procedure for Removing Spelter Core

- A. Cut the rope close (1/2") to the nose of the socket and press the cone out of the basket.
- B. We do not recommend the use of heat to remove the spelter cone for metallurgical, medical and environmental reasons.
  1. However, if this is the only means available for removing the zinc cone, care should be taken not to exceed 850°F (450°C) surface temperature. The preferred method would be slow heat in a temperature controlled oven. If a torch (rosebud) is used, the heat spot shall be monitored with a tempil stick or a temperature indicator to prevent localized heating from exceeding the 850°F (450°C) limit.
  2. To remove a **WIRELOCK**® cone, heat the surface of the socket to 350°F (do not exceed the 850°F limit for any localized hot spot). Leave for 5-10 minutes, then drive the cone out with a hammer and drift.

### II. Selection of Sockets for Reuse

- A. Use only sockets that:
  - Do not show discoloration from excessive heating.
  - Do not show any signs of welding.
- B. Select only sockets that have been cleaned and have passed a Magnetic Particle Inspection by a qualified technician (Level II ASNT-SNT-TC-1A-88) per ASTM E709. Acceptance criteria shall be per ASTM E125, Types II-VIII, Degree 1. No cracks are acceptable.
- C. Select only sockets that do not show any signs of overloading or wear on the socket or pin, (i.e. elongated pin holes, undersized pins, etc.).
- D. Select sockets that are free from nicks, gouges and abrasions. Indications may be repaired by lightly grinding until surfaces are smooth, provided they do not reduce the dimensions by more than 10% of the nominal catalog dimension.
- E. Select sockets that are not distorted, bent or deformed.

**Note: Sockets having any of the indications as outlined above (A-E) shall not be reused.**

### III. Procedures for Speltering Sockets

- A. The proper procedure for speltering sockets can be found on pages 112-116 of the *Wire Rope Users Manual*, 2nd Edition, and in *American Petroleum Institute (API) Recommended Practice 9B (RP9B)*, 9th Edition, May 30, 1986.
- B. Some standards (API, ISO, BSI) recommend preheating of the zinc spelter socket before pouring. This temperature shall not exceed 850°F (450°C).

### IV. Proof Testing

- A. We recommend the socket assembly be proof tested at two (2) times the Working Load Limit (2 x WLL) assigned to the socketed assembly.

# WIRELOCK®

## WARNINGS AND APPLICATION INSTRUCTIONS

### ⚠ WARNING

- Incorrect use of WIRELOCK® can result in an unsafe termination which may lead to serious injury, death, or property damage.
- Do not use WIRELOCK® with stainless steel rope in salt water environment applications.
- Use only soft annealed iron wire for seizing.
- Do not use any other wire (copper, brass, stainless, etc.) for seizing.
- Never use an assembly until the WIRELOCK® has gelled and cured.
- Remove any non-metallic coating from the broomed area.
- Non Crosby sockets with large grooves need to have those grooves filled before use with WIRELOCK®.
- Read, understand, and follow these instructions and those on product containers before using WIRELOCK®.

The following simplified, step-by-step instructions should be used only as a guide for experienced, trained users. For full information, consult our document **WIRELOCK® TECHNICAL DATA MANUAL, API (AMERICAN PETROLEUM INSTITUTE) RECOMMENDED PRACTICE 9B, ISO standards, WIRE ROPE MANUFACTURERS CATALOGS, and WIRE ROPE SLING USERS MANUAL, THIRD EDITION.**

### STEP 1 – SOCKET SELECTION

1. WIRELOCK® is recommended for use with Crosby 416-417 Spelter Sockets. Structural strand requires a socket with the basket length approximately five (5) times the strand diameter or fifty (50) times the wire diameter, what ever is greater to achieve 100% efficiency. Consult The Crosby catalog for proper selection of Wire Rope or Structural Strand sockets.
2. For use with sockets other than Crosby 416-417, consult the socket manufacturer or Crosby Engineering.
3. Sockets used with WIRELOCK® shall comply with Federal or International (CEN, ISO) Standards.
4. WIRELOCK®, as with all socketing media, depends upon the wedging action of the cone within the socket basket to develop full efficiency. A rough finish inside the socket may increase the load at which seating will occur. Seating is required to develop the wedging action.

### STEP 2 – MEASURE AND SEIZE

The rope ends to be socketed should be of sufficient length so that the end of the unlaidd wires (from the strands) will be at the top of the socket basket. Seizing should be placed at a distance from the end equal to the length of the basket of the socket.

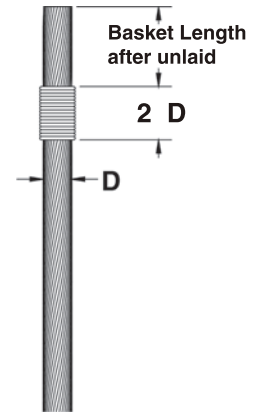

### STEP 3 – BROOMING

1. Unlay the individual strands and fully broom out the wires of the wire rope and IWRC as far as the seizing. The wires should be separated but not straightened.
2. Cut out any fiber core.
3. Unlay the individual wires from each strand, including the IWRC, completely down to the seizing.
4. Remove any plastic material from broomed area.



### STEP 4 – CLEANING

1. The method of cleaning will depend on the lubricant and/or coating on the wire.
2. The methods and materials used for cleaning should comply with the current EPA regulations.
3. Consult your Wire Rope supplier or Wire Rope manufacturer for recommended material and methods. Follow the solvent supplier's recommendations for cleaning the broomed end.

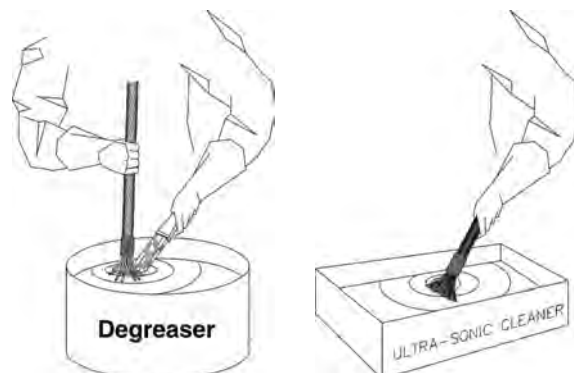

## STEP 5 – POSITIONING OF SOCKET

1. Position socket over the broom until it reaches the seizing on the wire rope. The wires should be **LEVEL** with the top of the socket basket.
2. Clamp rope and socket vertically ensuring alignment of their axes.
3. **CAUTION: DO NOT USE OVERSIZED SOCKETS FOR WIRE ROPE.**

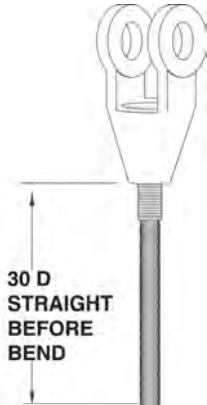

## STEP 6 – SEAL SOCKET

Seal the base of the socket with putty or plasticine to prevent leakage of the **WIRELOCK®**.



## STEP 7 – WIRELOCK® KITS

1. **WIRELOCK®** kits are pre-measured and consist of two (2) containers – one (1) with resin and one (1) with granular compound.
2. Use the complete kit – **NEVER MIX LESS THAN THE TOTAL CONTENTS OF BOTH CONTAINERS.**
3. Each kit has a shelf life clearly marked on each container and this must be observed. **NEVER USE OUT OF DATE KITS.**

### ⚠ CAUTION

- **WIRELOCK®** resin, in liquid state, is flammable.
- Chemicals used in this product can give off toxic fumes and can burn eyes and skin.
- Never use out-of-date material.
- Use only in well-ventilated work areas.
- Never breathe fumes directly or for extended time.
- Always wear safety glasses to protect eyes.
- Always wear gloves to protect hands.
- Avoid direct contact with skin anywhere.

## STEP 8 – MIXING AND POURING

1. Mix and pour **WIRELOCK®** within the temperature range of 48 degrees to 95 degrees F. Booster kits are available for reduced temperatures.
2. Wirelock is set up to gel in 20 minutes @ 65°F. For every 18° rise in temperature the gel time will halve. At 83°F the gel time will be 10 minutes and at 101°F it will be 5 minutes. To give extra working time or pot life it is worth considering refrigerating the kits for two hours prior to mixing and pouring. The temperature of the socket will affect the cure time as well. The socket should also be as cool as possible - out of direct sunlight, as an example.
3. Pour all the resin into a container containing all the granular compound and mix thoroughly for two (2) minutes with a flat paddle.
4. The **WIRELOCK®** will turn a green blue color. If it does not turn a green blue color after mixing, **DO NOT USE.**
5. Immediately after mixing, slowly pour the mixture down one side of the socket until the socket basket is full.
6. Check for leakage at nose of socket, add putty if required.

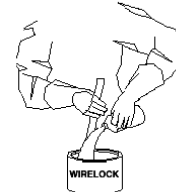

## STEP 9 – CURING

1. **WIRELOCK®** will gel in approximately fifteen (15) minutes, in a temperature range 65 degrees F to 75 degrees F.
2. The socket must remain undisturbed in the vertical position for an additional ten (10) minutes after gel is complete.
3. The socket will be ready for service sixty (60) minutes after gelling.
4. Never heat sockets to accelerate gel or curing.



## STEP 10 – RE-LUBRICATION

Re-lubricate wire rope as required.

## STEP 11 – PROOF LOADING

Whenever possible, the assembly should be proof loaded in accordance with ASME B30.9-2.6.

## ALTERNATE SEIZING AND BROOMING METHOD

Reference the **WIRELOCK® TECHNICAL DATA MANUAL** from Crosby for an alternative socketing method.



The Crosby S-423T Super TERMINATOR™ is the first wedge socket designed to take advantage of the performance properties associated with high performance, high strength, compacted strand, rotation resistant wire rope.

**The Super TERMINATOR™ offers several advantages over traditional methods of wedge socket terminations:**

- The innovative design will significantly increase the termination efficiency over existing wedge sockets available today.
- Terminations on most ropes have a minimum efficiency rating of 80% of the rope's catalog breaking strength.
- Patent pending design eliminates the difficulty of installing high performance, high strength, compacted strand, rotation resistant wire rope into a wedge socket termination.
- Proper application of the Super TERMINATOR™ eliminates the "first load" requirement of conventional wedge socket terminations.

**Additional features:**

- Wire rope sizes available:  
5/8" - 1 1/4", 14 mm - 32 mm
- Available as a complete assembly, or as a wedge kit that can be retrofitted onto existing Crosby S-421T TERMINATOR™ wedge sockets.
- Wedge accessories provided with a zinc finish.
- Meets or exceeds all ASME B30.26 requirements including: identification, ductility, design factor, proof load, and temperature requirements. Importantly, they meet other critical performance criteria not addressed by ASME B30.26 including: fatigue life, impact properties and material traceability.
- Available with bolt, nut and cotter (S-423TB)

**The Super TERMINATOR™ by Crosby.  
The first wedge socket termination  
designed specifically for high  
performance wire rope.**

**S-423T  
Super  
Terminator™**



[www.thecrosbygroup.com](http://www.thecrosbygroup.com)

# Wedge Socket Terminations

S-421T



US-422T



S-423T



## Table of Contents

Wedge Socket Application and General Information .....	98-99	Wedge Socket Warnings and Application Instructions .....	102-103
S-421T Wedge Sockets .....	100	S-423T SUPER TERMINATOR™ .....	104
US-422T Utility Wedge Sockets .....	101	S-423T SUPER TERMINATOR™ Warnings and Application Instructions .....	105

# Wedge Socket Information

## Application and General Information



S-421T  
"Terminator"  
Figure 1



US-422T  
Utility  
Figure 2



S-432T "Super  
Terminator"  
Figure 3

Wedge sockets are commonly used on the end of crane ropes as a means to attach the hoisting rope to the crane block or overhaul ball. Primary advantages of wedge style sockets include:

- Simplicity of installing and detaching product from the end of wire rope.
- When a mechanical spliced eye or poured socket is not practical.
- Applications where "on the job" attachment and quick or frequent rope replacement is necessary.

Crosby offers two standard styles of wedge sockets:

- The TERMINATOR™ Wedge Socket for use with standard wire ropes.
- The Super TERMINATOR™ Wedge Socket designed for high performance, high strength, compacted strand, rotation resistant wire rope.

## Efficiency

Efficiency ratings for wire rope terminations are based upon the minimum breaking force of wire rope.

*S-421T and US-422T Sockets* – The efficiency of Crosby Wedge Sockets is 80 percent when installed properly.

*S-423T Super Terminator Sockets* – Due to the unique construction of the various high performance, high strength, compacted strand, rotation resistant wire ropes, Crosby cannot make a broad general statement that all current and future designed ropes, when properly assembled with a Super TERMINATOR™ will achieve a minimum of 80 percent efficiency rating. To determine the efficiency rating for a specific rope, contact Crosby Engineering at 918-834-4611. The rated load for wire rope assemblies such as wedge sockets is based on the following factors:

1. Wire rope minimum breaking force
2. 80 percent minimum connection efficiency
3. Design factor of the wire rope application

The schematic below depicts the parts of a typical Crosby S-421T and US-422T TERMINATOR™ Wedge Socket.

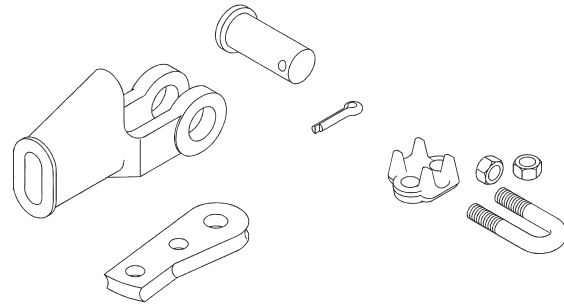

The schematic below depicts the parts of a typical Crosby S-423T "Super TERMINATOR™" Wedge Socket.

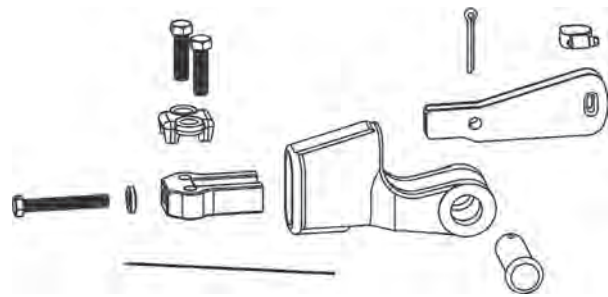

## Key Facts About Wedge Sockets

1. S-421T and US-422T Wedge Socket terminations have an efficiency rating of 80% based on the minimum breaking force of XXIP wire rope.
2. Meets or exceeds all requirements of ASME B30.26 including identification, ductility, design factor, proof load and temperature requirements. Importantly, these sockets meet other critical performance requirements including fatigue life, impact properties and material traceability, not addressed by ASME B30.26.
3. The intended purpose of the SUPER TERMINATOR™ is to offer a wedge socket termination, which when assembled properly with high performance, high strength, compacted strand, rotation resistant wire rope will achieve an 80% termination efficiency. Due to the unique construction of these ropes, Crosby cannot make a broad general statement that all current and future designed ropes, when properly assembled with a SUPER TERMINATOR™, will achieve a minimum 80% termination efficiency. (To determine the efficiency rating for a specific rope, contact Crosby Engineering at 918-834-4611.)
4. Type Approval and certification in accordance with ABS 2006 Steel Vessel Rules 1-1-17.7, and ABS Guide for Certification of Cranes.
5. Basket is cast steel and Individually Magnetic Particle Inspected.

# Wedge Socket Information

6. Pin diameter and jaw opening allows wedge and socket to be used in conjunction with closed swage and spelter sockets.
7. Crosby TERMINATOR™ Wedge Sockets secure the tail or “dead end” of the wire rope to the wedge, thus eliminating loss or “punch out” of the wedge.
8. The TERMINATOR™ Wedge eliminates the need for an extra piece of rope, and is easily installed.
9. The TERMINATOR™ Wedge eliminates the potential breaking off of the tail due to fatigue.
10. The tail, which is secured by the base of the clip and the wedge, is left undeformed and available for reuse.
11. Utilizes standard Crosby Red-U-Bolt® wire rope clip.
12. The 3/8” thru 1-1/8” standard S-421 wedge socket can be retrofitted with the new style TERMINATOR™ Wedge.
13. Available with bolt, nut and cotter pin.
14. U.S. patent 5,553,360, Canada patent 2,217,004 and foreign equivalents.
15. Meets the performance requirements of EN 13411-6:200.
16. The SUPER TERMINATOR™ may be purchased as a complete wedge socket assembly or the wedge assembly may be purchased for retrofit onto your Crosby S-421T wedge socket basket.
17. The Crosby S-423TW SUPER TERMINATOR™ Wedge is designed to be assembled only into the Crosby S-421T socket basket. For the 1-1/4” S-423TW, assemble only on to S-421T basket marked TERMINATOR™.
18. Do not mix and match wedges or pins between models or sizes.
19. The SUPER TERMINATOR™ Wedge Socket may also be used with standard 6 to 8 strand and rotation resistant wire rope (special wire rope constructions with 8 or more strands).

## Standard Considerations When Utilizing Wedge Sockets

### ASME B30.5

Mobile and Locomotive Cranes, Section 5-1.7.1(d) states “The design factor specified in paras. 5-1.7.1(a) through (c) shall be the total minimum breaking strength of all ropes in the system divided by the load imposed on the rope system when supporting the static weights of structure and crane load. The absence of a derating of the wire rope breaking strength due to termination efficiency in paragraph 5-1.7.1(d) indicates that the termination efficiency was considered in the establishment of the design factors.

The methodology used in ASME B30.5 is not without precedent. API specification 2C for Offshore Pedestal Mounted Cranes 6th Edition, states “Wire rope design

factors are intended to account for end connector efficiency and total reeving system efficiency of 80% or greater.”

ASME B30.5 requires that “Wire rope clips used in conjunction with wedge sockets shall be attached to the unloaded dead end of the rope only.”

### ASME B30.26

The wedge socket shall be assembled as recommended by the manufacturer or a qualified person.

Wedge socket materials shall be of sufficient strength such that failure of the wire rope will occur before failure of the wedge socket.

Before installing a wedge socket on plastic coated or plastic impregnated wire rope, consult the manufacturer or a qualified person.

Each new wedge socket body and wedge shall have forged, cast, or die stamped marking by the manufacturer to show:

- Name or trademark of manufacturer
- Size
- Model, if required to match wedge to body

Crosby wedge sockets exceed ASME B30.26 identification requirements.

The live end of wire rope in the wedge socket cavity shall be in alignment with the socket’s pin.

The assembler shall match the proper wedge with the socket for the wire rope to be installed.

Wedges shall not be interchanged between different manufacturers’ sockets or models.

The length of dead end tail of the wire rope shall be as required by the manufacturer or a qualified person.

The dead end of the wire rope shall not be secured to the live end of the wire rope such that it restricts the movement of the live end.

Shock loading should be avoided.

See ASME B30.26 for full information.

# S-421T Wedge Sockets



**SEE APPLICATION AND WARNING INFORMATION**

Para Español: [www.thecrosbygroup.com](http://www.thecrosbygroup.com)

on Page 109

## S-421T



Wedge sockets meet the performance requirements of Federal Specification RR-S-550D, Type C, except those provisions required of the contractor. For additional information, see Crosby General Catalog.

- Wedge socket terminations have an efficiency rating of 80% based on the catalog strength of XXIP wire rope.
- Meets or exceeds all requirements of ASME B30.26 including identification, ductility, design factor, proof load and temperature requirements. Importantly, these sockets meet other critical performance requirements including fatigue life, impact properties and material traceability, not addressed by ASME B30.26.
- Type Approval and certification in accordance with ABS 2006 Steel Vessel Rules 1-1-17.7, and ABS Guide for Certification of Cranes.
- Basket is cast steel and individually Magnetic Particle Inspected.
- Pin diameter and jaw opening allows wedge and socket to be used in conjunction with closed swage and spelter sockets.
- Secures the tail or "dead end" of the wire rope to the wedge, thus eliminates loss or "Punch out" of the wedge.
- Eliminates the need for an extra piece of rope, and is easily installed.
- The TERMINATOR™ Wedge eliminates the potential breaking off of the tail due to fatigue.
- The tail, which is secured by the base of the clip and the wedge, is left undeformed and available for reuse.
- Incorporates Crosby's patented QUIC-CHECK® "Go" and "No-Go" feature cast into the wedge. The proper size rope is determined when the following criteria are met:
  - 1) The wire rope should pass thru the "Go" hole in the wedge.
  - 2) The wire rope should NOT pass thru the "No-Go" hole in the wedge.
- Utilizes standard Crosby Red-U-Bolt® wire rope clip.
- The 3/8" thru 1-1/8" standard S-421 wedge socket can be retrofitted with the new style TERMINATOR™ Wedge.
- Available with Bolt, Nut, and Cotter Pin.
- U.S. patent 5,553,360, Canada patent 2,217,004 and foreign equivalents.
- Meets the performance requirements of EN 13411-6: 2003.

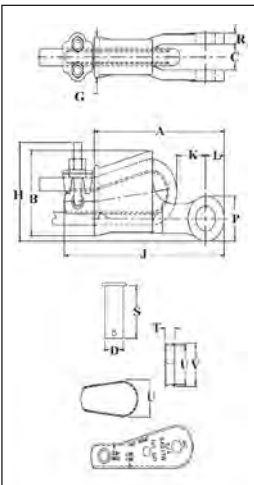

## S-421T Wedge Sockets

### Assembly includes Socket, Wedge, Pin and Wire Rope Clip

Wire Rope Dia.		S-421T Stock No.	Weight Each (lbs.)	S-421TW Stock No. Wedge Only	Wedge Only Weight Each (lbs.)	Optional G-4082 Bolt, Nut & Cotter	
(in.)	(mm)					G-4082 Stock No.	Weight Each (lbs.)
3/8	9-10	1035000	3.18	1035555	.50	1092227	.38
1/2	11-13	1035009	6.15	1035564	1.05	1092236	.69
5/8	14-16	1035018	9.70	1035573	1.79	1092254	1.15
3/4	18-19	1035027	14.50	1035582	2.60	1092281	1.91
7/8	20-22	1035036	21.50	1035591	4.00	1092307	3.23
1	24-26	1035045	30.75	1035600	5.37	1092325	5.40
1-1/8	28	1035054	45.30	1035609	7.30	1092343	7.50
1-1/4	30-32	1035063	64.90	1035618	10.60	1092372	10.34

Wire Rope Dia.		S-421T Stock No.	Dimensions (in.)														
(in.)	(mm)		A	B	C	D	G	H	J*	K*	L	P	R	S	T	U	V
3/8	9-10	1035000	5.69	2.72	.81	.81	1.38	3.06	7.80	1.88	.88	1.56	.44	2.13	.44	1.25	1.38
1/2	11-13	1035009	6.88	3.47	1.00	1.00	1.62	3.76	8.91	1.26	1.06	1.94	.50	2.56	.53	1.75	1.88
5/8	14-16	1035018	8.25	4.30	1.25	1.19	2.12	4.47	10.75	1.99	1.22	2.25	.56	3.25	.69	2.00	2.19
3/4	18-19	1035027	9.88	5.12	1.50	1.38	2.44	5.28	12.36	2.41	1.40	2.63	.66	3.63	.78	2.34	2.56
7/8	20-22	1035036	11.25	5.85	1.75	1.63	2.69	6.16	14.37	2.48	1.67	3.13	.75	4.31	.88	2.69	2.94
1	24-26	1035045	12.81	6.32	2.00	2.00	2.94	6.96	16.29	3.04	2.00	3.75	.88	4.70	1.03	2.88	3.28
1-1/8	28	1035054	14.38	6.92	2.25	2.25	3.31	7.62	18.34	2.56	2.25	4.25	1.00	5.44	1.10	3.25	3.56
1-1/4	30-32	1035063	16.34	8.73	2.62	2.50	3.56	9.39	20.48	2.94	2.34	4.50	1.06	6.13	1.19	4.62	4.94

\* Nominal NOTE: For intermediate wire rope sizes, use next larger size socket.

The S-423T Super TERMINATOR™ Wedge is designed to be assembled only into the Crosby S-421T TERMINATOR™ socket body.

**IMPORTANT:** The S-423TW for sizes 5/8" through 1-1/8" (14mm through 28mm) will fit respective size standard Crosby S-421T Basket. The 1-1/4" (30-32mm) S-423TW will only fit the Crosby S-421T 1-1/4" basket marked with "TERMINATOR™"

# US-422T Utility Wedge Sockets



**SEE APPLICATION AND WARNING INFORMATION**

Para Español: [www.thecrosbygroup.com](http://www.thecrosbygroup.com)

on Page 110

## US-422T



Most sizes now incorporate the "TERMINATOR™" design and may vary in shape from above product shown.

- Basket is cast steel and individually Magnetic Particle Inspected.
- Wedge socket terminations have an efficiency rating of 80% based on the catalog strength of XXIP wire rope.
- Wedges are color coded for easy identification.
  - Blue - largest wireline size for socket.
  - Black - mid size wireline for socket.
    - 7/16" on US4
    - 9/16" on US5
  - Orange - smallest wireline size for socket.
- Cast into each socket is the name "McKissick", "Crosby" or "CG", its model number and its wireline range.
- By simply changing out the wedge, each socket can be utilized for various wireline sizes (Ensure correct wedge is used for wire rope size).
- Cast into each wedge is the model number of the socket and the wireline size for which the wedge is to be used.
- Load pin is forged and headed on one end.
- US-422T Wedge Sockets contain a hammer pad (lip) to assist in proper securement of termination.
- Meets or exceeds all requirements of ASME B30.26 including identification, ductility, design factor, proof load and temperature requirements. Importantly, these sockets meet other critical performance requirements including fatigue life, impact properties and material traceability, not addressed by ASME B30.26.
- UWO-422T Wedges are to be used only with the US-422T Wedge Socket Assemblies.

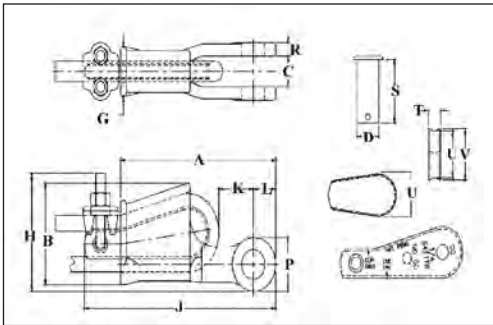

## US-422T Utility Wedge Sockets

Model No.	Wire Rope Size		US-422T Stock No.	Weight Each (lbs.)	Wedge Only Stock No.	Weight Each (lbs.)	Dimensions (in.)														
	(in.)	(mm)					A	B	C	D	G	H	J	K	L	P	R	S	T	U	V
US4T	3/8	10	1044300	4.6	1047310	.6	6.81	3.55	1.00	1.00	1.63	2.81	8.43	1.38	1.06	1.94	.50	2.53	.44	1.91	2.14
US4T	7/16	11	1044309	4.6	1047301	.6	6.81	3.55	1.00	1.00	1.63	2.81	8.73	1.08	1.06	1.94	.50	2.53	.53	1.76	1.88
US4T	1/2	13	1044318	4.6	1047329	.6	6.81	3.55	1.00	1.00	1.63	2.81	8.73	1.02	1.06	1.94	.50	2.53	.53	1.76	1.88
US5T	1/2	13	1044327	8.5	1047338	1.0	9.19	4.23	1.41	1.25	2.13	3.31	11.19	1.84	1.50	3.00	.63	3.25	.75	1.92	2.16
US5T	9/16	14	1044336	8.5	1047347	1.0	9.19	4.23	1.41	1.25	2.13	3.31	11.47	2.40	1.50	3.00	.63	3.25	.69	2.00	2.18
US5T	5/8	16	1044345	8.5	1047356	1.0	9.19	4.23	1.41	1.25	2.13	3.31	11.47	2.34	1.50	3.00	.63	3.25	.69	2.00	2.18
US6T	5/8	16	1044354	9.4	1047365	1.4	9.45	4.70	1.50	1.25	2.24	3.63	11.91	2.48	1.50	3.00	.56	3.25	.88	2.38	2.75
US6T	3/4	19	1044363	9.4	1047374	1.4	9.45	4.70	1.50	1.25	2.24	3.63	11.81	2.03	1.50	3.00	.56	3.25	.88	2.13	2.63
US8AT	5/8	16	1044372	19.8	1047383	4.3	10.59	5.68	1.81	1.63	2.38	5.53	13.19	1.91	1.53	2.88	.75	4.13	.69	3.26	3.50
US8AT	3/4	19	1044381	20.4	1047392	4.8	10.59	5.68	1.81	1.63	2.38	5.84	13.54	2.38	1.53	2.88	.75	4.13	.78	3.12	3.38
US7*	7/8	22	1038580	16.5	1046674	2.6	11.26	5.11	1.31	1.25	2.69	—	—	2.56	1.63	3.26	.66	3.25	1.06	2.12	2.56
US7*	1	25	1038589	16.5	1046683	2.6	11.26	5.11	1.31	1.25	2.69	—	—	2.56	1.63	3.26	.66	3.25	1.06	1.88	2.38
US8T	7/8	22	1044404	31.5	1047425	7.6	12.77	6.96	1.81	1.63	3.06	7.20	16.02	2.87	1.65	3.12	.75	4.13	.88	3.88	4.18
US8T	1	25	1044417	32.5	1047431	8.6	12.77	6.96	1.81	1.63	3.06	7.31	16.41	2.32	1.65	3.12	.75	4.13	1.03	3.76	4.06
US10T	1-1/8	28	1044426	55.4	1047440	12.5	15.94	8.62	1.81	1.63	3.57	9.15	19.72	3.26	2.19	4.38	.75	4.13	1.09	4.76	5.06
US10T	1-1/4	32	1044435	58.0	1047459	15.0	15.94	8.62	1.81	1.63	3.57	9.39	20.22	2.83	2.19	4.38	.75	4.13	1.19	4.62	4.94
US11T	1-1/8	28	1044444	60.6	1047468	12.5	16.34	8.73	2.62	2.50	3.56	9.15	19.97	3.37	2.34	4.50	1.06	6.13	1.09	4.76	5.06
US11T	1-1/4	32	1044453	64.9	1047477	15.0	16.34	8.73	2.62	2.50	3.56	9.39	20.48	2.94	2.34	4.50	1.06	6.13	1.19	4.62	4.94

\* Non-"TERMINATOR™" Style

# S-423T SUPER TERMINATOR™



**SEE APPLICATION AND WARNING INFORMATION**

Para Español: [www.thecrosbygroup.com](http://www.thecrosbygroup.com)

on Page 111

## S-423T



Wedge sockets meet the performance requirements of Federal Specification RR-S-550D, Type C, except those provisions required of the contractor. Meets the performance requirements of EN13411-6:2003. For additional information, see Crosby General Catalog.

- Wedge socket terminations have a minimum efficiency rating on most high performance, high strength, compacted strand, rotation resistant wire ropes of 80% based on the catalog breaking strength of the various ropes.\*\*
- Patent Pending design eliminates the difficulty of installing high performance wire rope into a wedge socket termination.
- Proper application of the Super TERMINATOR™ eliminates the “first load” requirement of conventional wedge socket terminations.
- S-423TW Wedge Kit can be retrofitted onto existing Crosby S-421T TERMINATOR™ Wedge Sockets.
- Wedge and accessories provided with a zinc finish.
- Meets the performance requirements of EN13411-6:2003.
- Meets or exceeds all requirements of ASME B30.26 including identification, ductility, design factor, proof load and temperature requirements. Importantly, these sockets meet other critical performance requirements including fatigue life, impact properties and material traceability, not addressed by ASME B30.26.
- Basket is cast steel and Individually Magnetic Particle Inspected.
- Pin diameter and jaw opening allows wedge and socket to be used in conjunction with closed swage and spelter sockets.
- Secures the tail or “dead end” of the wire rope to the wedge, thus eliminates loss or “punch out” of the wedge.
- Eliminates the need for an extra piece of rope, and is easily installed.
- The TERMINATOR™ Wedge eliminates the potential breaking off of the tail due to fatigue.
- The tail, which is secured by the base of the clip and the tension device, is left undeformed and available for reuse.
- Available with Bolt, Nut, and Cotter Pin.

**\*\* NOTICE:** Due to the unique construction of various ropes, Crosby cannot make a broad general statement that all current and future design of ropes, when properly assembled with the Super TERMINATOR™, will achieve a minimum 80% termination efficiency. Contact wire rope manufacturer or Crosby Engineering (918-834-4611) to determine efficiency rating for a specific rope.

## S-423T Wedge Sockets Assembly includes Socket, Wedge, Pin, Wire Rope Clip, Tensioner, Bolts and Secondary Retention Wire.

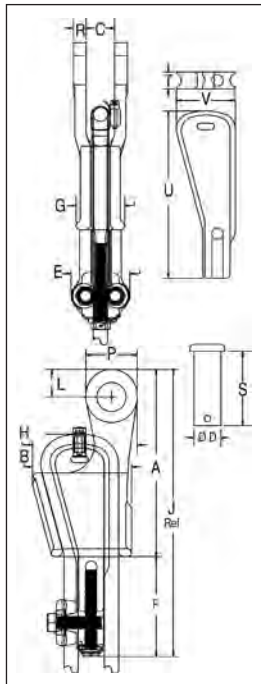

Wire Rope Dia.		S-423T Assembly with Round Pin and Cotter Pin			S-423TB Assembly with Bolt, Nut and Cotter Pin			S-423TW** Wedge Kit		
(in.)	(mm)	S-423T Stock No.	S-423T Weight Each		S-423TB Stock No.	S-423TB Weight Each		S-423TW Stock No.	S-423TW Weight Each	
			(lbs.)	(kg)		(lbs.)	(kg)		(lbs.)	(kg)
5/8	14-16	1035123	12.7	5.8	1035218	13.1	5.9	1034018	5.2	2.4
3/4	18-19	1035132	19.4	8.8	1035227	19.1	8.7	1034027	7.2	3.3
7/8	20-22	1035141	28.8	13.1	1035236	27.8	12.6	1034036	10.3	4.7
1	24-26	1035150	39.2	17.8	1035245	37.3	16.9	1034045	11.9	5.4
1-1/8	28	1035169	57.1	25.9	1035254	57.9	25.9	1034054	19.9	9.0
1-1/4	30-32	1035178	88.6	40.2	1035272	88.1	39.9	1034063	33.8	15.3

\*\* Kit contains Wedge, Wire Rope Clip and Bolts, Tensioner, Tensioner Bolt and Secondary Retention Wire.

Wire Rope Dia. (in.)	S-423T Stock No.	Dimensions (in.)																
		A	B	C	D	G	F	G	H	J*	L	P	R	S	T	U	V	
5/8	14-16	1035123	8.25	4.50	1.25	1.19	3.00	4.06	2.13	4.61	12.31	1.22	2.25	.56	3.25	.75	6.88	2.60
3/4	18-19	1035132	9.88	5.20	1.50	1.38	3.25	4.81	2.44	5.37	14.69	1.40	2.62	.66	3.63	.88	7.65	3.02
7/8	20-22	1035141	11.25	5.88	1.75	1.63	3.81	5.73	2.69	6.16	16.98	1.67	3.13	.75	4.31	1.00	9.47	3.47
1	24-26	1035150	12.81	6.56	2.00	2.00	3.81	5.73	2.94	7.05	18.54	2.01	3.75	.88	4.70	1.13	10.41	3.82
1-1/8	28	1035169	14.38	6.94	2.25	2.25	4.00	6.85	3.38	7.81	21.23	2.26	4.25	1.00	5.44	1.25	11.83	4.22
1-1/4	30-32	1035178	16.34	8.63	2.62	2.50	4.50	7.76	3.57	9.38	24.10	2.34	4.50	1.06	6.62	1.38	13.87	5.82

\* Nominal

**NOTE:** For intermediate wire rope sizes, use next larger size socket.

The S-423T Super TERMINATOR™ wedge is designed to be assembled only into the Crosby S-421T TERMINATOR™ Socket Body.

**IMPORTANT:** The S-423TW for sizes 5/8" through 1-1/8" (14mm through 28mm) will fit respective size standard Crosby S-421T Basket. The 1-1/4" (30-32mm) S-423TW will only fit the Crosby S-421T 1-1/4" basket marked with "TERMINATOR™".

# WEDGE SOCKET

## WARNINGS AND APPLICATION INSTRUCTIONS

Extended Wedge Socket Assembly U.S. Patent No. 5,553,360 and Canada Patent No. 2,217,004

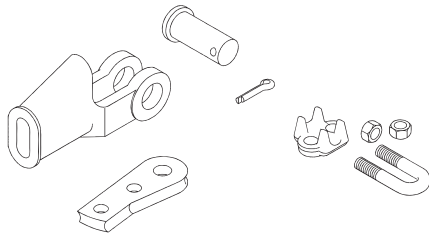

**S-421T / US-422T  
"TERMINATOR"™**

**NOTE:** The design of the basket for the S-421T 1-1/4" TERMINATOR™ Wedge Socket does not allow proper fit to the old style Crosby S-421W wedge (see Fig. 1). **Do not assemble or use.**

The design of the basket for each US-422T TERMINATOR™ Wedge Socket does not allow proper fit to the old style UWO-422 wedge (See Fig. 1). **Do not assemble or use.**

All S-421T and US-422T TERMINATOR™ baskets are marked with a capital "T" or TERMINATOR™.

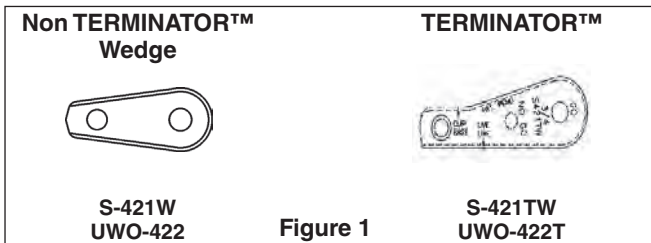

**QUIC-CHECK®** "Go" and "No-Go" features cast into wedge. The proper size wire rope is determined when the following criteria are met:

1. The wire rope shall pass thru the "Go" hole in the wedge.
2. The wire rope shall NOT pass thru the "No-Go" hole in the wedge.



### Important Safety Information – Read and Follow Inspection/Maintenance Safety

- Always inspect socket, wedge and pin before using.
- Do not use part showing cracks.
- Do not use modified or substitute parts.
- Repair minor nicks or gouges to socket or pin by lightly grinding until surfaces are smooth. Do not reduce original dimension more than 10%. Do not repair by welding.
- Inspect permanent assemblies annually, or more often in severe operating conditions.
- Do not mix and match wedges or pins between models or sizes.
- Always select the proper wedge and socket for the wire rope size.

### Assembly Safety

- Use only with standard 6 to 8 strand wire rope of designated size. For intermediate size rope, use next larger size socket. For example: When using 9/16" diameter wire rope use a 5/8" size Wedge Socket Assembly. Welding of the tail on standard wire rope is not recommended. The tail length of the dead end should be a minimum of 6 rope diameters but not less than 6" (See Figure 2).
- **To use with Rotation Resistant** wire rope (special wire rope constructions with 8 or more outer strands) ensure that the dead end is welded, brazed or seized before inserting the wire rope into the wedge socket to prevent core slippage or loss of rope lay. The tail length of the dead end should be a minimum of 20 rope diameters but not less than 6" (See Figure 2).
- Properly match socket, wedge and clip (See Table 1) to wire rope size.

- Align live end of rope, with center line of pin. (See Figure 2)
- Secure dead end section of rope. (See Figure 2)
- Do not attach dead end to live end or install wedge backwards (See Fig. 3).
- **Use a hammer to seat Wedge and Rope as deep into socket as possible before applying first load.**

### WARNING

- **Loads may slip or fall if the Wedge Socket is not properly installed.**
- **A falling load can seriously injure or kill.**
- **Read and understand these instructions before installing the Wedge Socket.**
- **Do not side load the Wedge Socket.**
- **Apply first load to fully seat the Wedge and Wire Rope in the socket. This load should be of equal or greater weight than loads expected in use.**
- **Do not interchange wedges between S-421T and US422T or between sizes.**
- **Do not assemble an old style 1-1/4" S-421W wedge into an S-421T 1-1/4" TERMINATOR™ basket.**
- **Do not assemble an old style UWO-422 Wedge into a US-422T TERMINATOR™ basket.**

**Figure 2**

*Tail Length	
Standard 6 to 8 Strand Wire Rope	Rotation Resistant Wire Rope
A minimum of 6 rope diameters, but not less than 6"	A minimum of 20 rope diameters, but not less than 6"

**TABLE 1**

Rope Size	3/8	1/2	5/8	3/4	7/8	1	1-1/8	1-1/4
Clip Size	3/8	1/2	5/8	3/4	7/8	1	1-1/8	1-1/4
* Torque Ft./lbs.	45	65	95	130	225	225	225	360

\* The tightening torque values shown are based upon the threads being clean, dry, and free of lubrication.

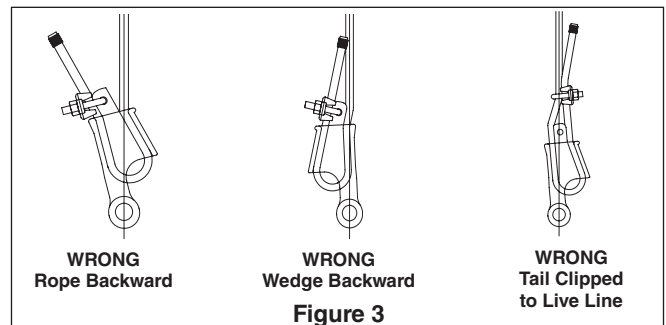

### Operating Safety

- Apply first load to fully seat the Wedge and Wire Rope in the socket. This load should be of equal or greater weight than loads expected in use.
- Efficiency rating of the Wedge Socket termination is based upon the catalog breaking strength of Wire Rope. The efficiency of a properly assembled Wedge Socket is 80%.
- During use, do not strike the dead end section with any other elements of the rigging (called two blocking).

## WEDGE SOCKET

### WARNINGS AND APPLICATION INSTRUCTIONS

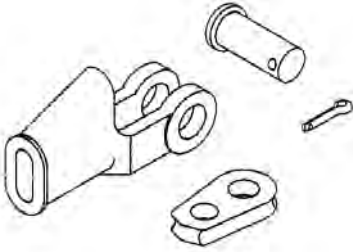

S-421 / US-422

#### Important Safety Information - Read and Follow Inspection/Maintenance Safety

- Always inspect socket, wedge and pin before using.
- Do not use part showing cracks.
- Do not use modified or substitute parts.
- Repair minor nicks or gouges to socket or pin by lightly grinding until surface are smooth. Do not reduce original dimension more than 10%. Do not repair by welding.
- Inspect permanent assemblies annually, or more often in severe operating conditions.
- Do not mix and match wedges or pins between models or sizes.
- Always select the wedge and socket for the wire rope size.

#### Assembly Safety

- Use only with standard 6 to 8 strand wire rope of designated size. For intermediate size rope, use next larger size socket. For example: When using 9/16" diameter wire rope use a 5/8" size Wedge Socket Assembly. Welding of the tail on standard wire rope is not recommended. The tail length of the dead end should be a minimum of 6 rope diameters but not less than 6".
- Align live end of rope, with center line of pin. (See Figure 1)
- Secure dead end section of rope. (See Figure 1)
- DO NOT ATTACH DEAD END TO LIVE END. (See Figure 1)
- Use a hammer to seat Wedge and Rope as deep into socket as possible before applying first load.
- To use with Rotation Resistant wire rope (special wire rope constructions with 8 or more outer strands) ensure that the dead end is welded, brazed or sized before inserting the wire rope into wedge socket to prevent core slippage or loss of rope lay. The tail length of the dead end should be a minimum of 20 rope diameters but not less than 6" (Figure 1)

### WARNING

- Loads may slip or fall if the Wedge Socket is not properly installed.
- Load misapplied in direct contact with the wedge can dislodge the wedge & cause loss of load.
- A falling load can seriously injure or kill.
- Read and understand these instructions before installing the Wedge Socket.
- Do not side load the wedge socket.
- Do not interchange Crosby wedge socket, wedge or pin with non Crosby Wedge socket, wedge or pin.
- Apply first load to fully seat the Wedge and Wire Rope in the socket. This load should be of equal or greater weight than loads expected in use.
- Do not interchange wedge between S-421 and US-422 or between sizes.

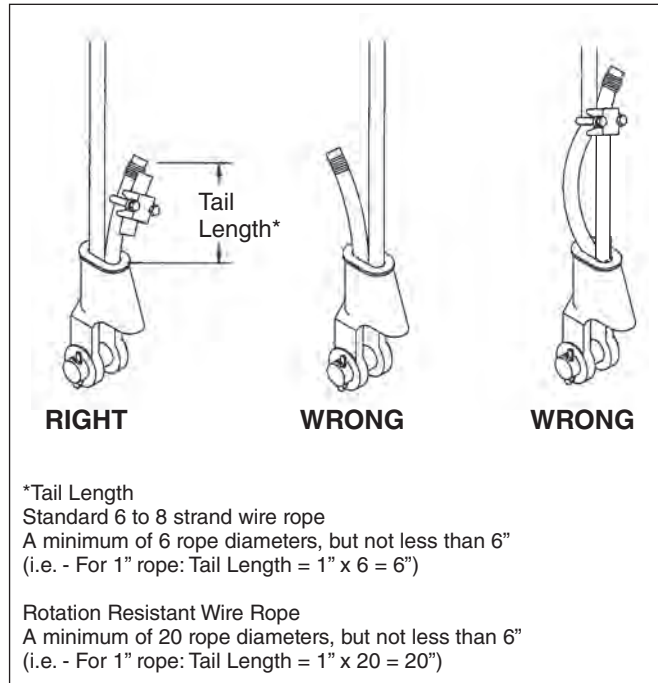

Figure 1

#### Operating Safety

- Apply first load to fully seat the Wedge and Wire Rope in the socket. This load should be of equal or greater weight than loads expected in use.
- Efficiency rating of the Wedge Socket termination is based upon the catalog breaking strength of Wire Rope. The efficiency of properly assembled Wedge Socket is 80%.
- During use, do not strike the dead end section with any other elements of the rigging (called two-blocking).
- Do not allow a direct load to contact the wedge.

# SUPER TERMINATOR™ WEDGE SOCKET WARNING & APPLICATION INSTRUCTIONS

Patent Pending

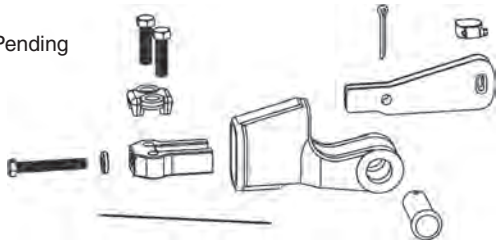

## S-423T "SUPER TERMINATOR™"

The intended purpose of the SUPER TERMINATOR™ is to offer a Wedge Socket termination, which when assembled properly with high performance, high strength, compacted strand, rotation resistant wire rope will achieve an 80% termination efficiency. Due to the unique construction of these ropes, Crosby cannot make a broad general statement that all current and future designed ropes, when properly assembled with a SUPER TERMINATOR™, will achieve a minimum 80% termination efficiency. (To determine the efficiency rating for a specific rope, contact Crosby Engineering at 918-834-4611.)

The SUPER TERMINATOR™ may be purchased as a complete Wedge Socket assembly or the wedge assembly may be purchased for retrofit onto your Crosby S-421T wedge socket basket.

The Crosby S-423TW SUPER TERMINATOR™ Wedge is designed to be assembled only into the Crosby S-421T socket basket. For the 1-1/4" S-423TW, assemble only on to S-421T basket marked TERMINATOR™.

### Important Safety Information - Read and Understand Inspection/Maintenance Safety

- Always inspect socket, wedge and pin before using.
- Do not use part showing cracks.
- Do not use modified or substitute parts.
- Repair minor nicks or gouges to socket or pin by lightly grinding until surfaces are smooth. Do not reduce original dimension more than 10%. Do not repair by welding.
- Inspect permanent assemblies annually, or more often in severe operating conditions.
- Do not mix and match wedges or pins between models or sizes.
- Always select the proper wedge and socket for the wire rope size.

### Assembly Safety

- Properly match socket and wedge assembly to wire rope size.
- Ensure the dead end is properly seized before inserting the wire rope into the wedge socket basket. High performance, high strength, compacted strand, rotation resistant wire ropes are sensitive to seizing methods. For specific seizing procedures, contact the wire rope manufacturer.
- The tail length of the dead end should be a minimum of 20 rope diameters but not less than 10" (See Fig. 1).
- Mount wedge socket basket in vice.
- Insert live end of wire rope into wedge basket, aligning live end of rope with center line of pin. Make a loop and return. (See Figure 2).
- Pull on live line to remove excess out of loop, leaving enough room to properly insert wedge into basket. (See Figure 3).
- Secure rope to SUPER TERMINATOR™ Wedge with clamp (See Figure 4).
- Pull Wedge and rope into basket until tensioner bolt, with washers properly applied, can engage threads in nose of wedge. (See Figure 5).
- Use torque wrench to tighten tensioner bolt to recommended torque value, properly seating wedge and rope into basket. Reference Table 1 for recommended Torque in Ft. Lbs.
- Secure dead end section of rope with clip base. Tighten bolts to recommended torque values (See Table 1).
- Properly install wire to securely lock tensioner bolt to tensioner. (See Figure 6).
- Do not attach dead end to live end or install wedge backwards. (See Figure 7).

### Operating Safety

- Proper application of the Super TERMINATOR™ eliminates the "first load" requirement of conventional wedge socket terminations.

- Efficiency rating of the Wedge Socket termination is based upon the catalog breaking strength of Wire Rope. The efficiency of a properly assembled Super Terminator on most high performance, high strength, compacted strand, rotation resistant ropes will achieve 80% of catalog breaking strength of rope, depending on the unique construction of these ropes. (To determine the efficiency rating for a specific rope, contact Crosby Engineering at 918-834-4611.)
- During use, do not strike the dead end section with any other elements of the rigging (Called two blocking).
- The SUPER TERMINATOR™ wedge socket may also be used with standard 6 to 8 strand and rotation resistant wire rope (special wire rope constructions with 8 or more strands).

## WARNING

- Loads may slip or fall if the Wedge Socket is not properly installed.
- A falling load can seriously injure or kill.
- Read and understand these instructions before installing the Wedge Socket.
- Do not side load the Wedge Socket.
- Apply recommended torque to tensioner and clip bolts, and properly install wire to securely lock tensioner bolt to tensioner.
- Do not assemble the S-423 Wedge in any brand or model socket basket other than the Crosby S-421T TERMINATOR™.
- The size is marked on the socket basket and wedge, do not interchange wedge between sizes.

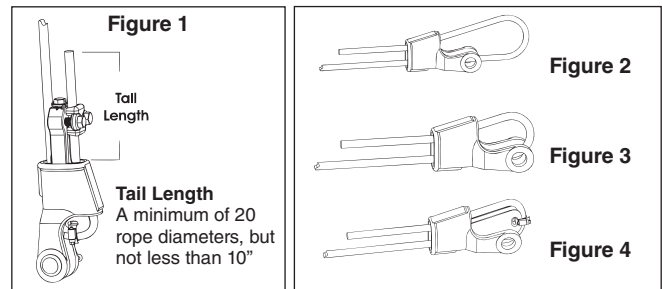

Wedge Size (in.)	Tensioner Bolt Torque Ft./lbs*	Clip Bolts Torque Ft./lbs*
5/8	110	95
3/4	150	130
7/8	380	225
1	380	225
1-1/8	600	225
1-1/4	900	360

\* The tightening torque values shown are based upon the threads being clean, dry, and free of lubrication.

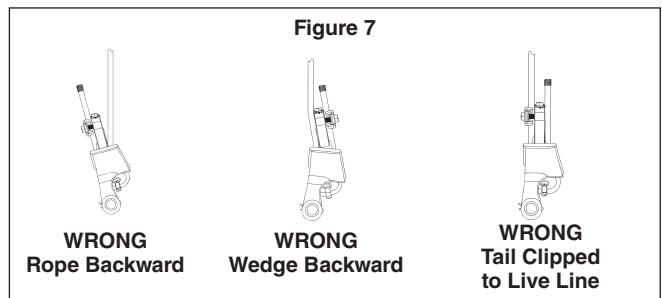
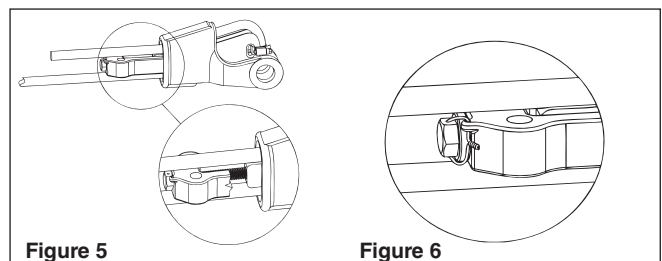

# Notes

---

# Wire Rope Clips

**G-450  
Wire Rope Clips**



**SS-450  
Stainless Steel  
Wire Rope Clips**



**New Style  
Fist Grip® Clips  
3/16" - 5/8"**



**Fist Grip® Clips  
3/4" - 1-1/2"**



## Table of Contents

Wire Rope Clip Information.....	108-109	Fist Grip® Wire Rope Clips.....	113
Forged Wire Rope Clips.....	110	Fist Grip® Clip Installation Procedures .....	114
U-Bolt Clip Installation Procedures .....	111	Crosby Fist Grip® Clips Warnings and Application Instructions .....	115
Crosby Clips Warnings and Application Instructions .....	112		

# Wire Rope Clip Information

## Application and General Information



G-450 Crosby Red-U-Bolt® Clip  
**Figure 1**



SS-450 Crosby Stainless Steel Clip  
**Figure 2**



G-429 Crosby Fist Grip® Clip 3/16"-5/8"  
**Figure 3**



G429 Crosby Fist Grip® Clip 3/4"-1-1/2"  
**Figure 4**

There are three basic types of wire rope clips – forged U-Bolt, forged fist grip, and cast malleable. Wire rope clips are sometimes referred to as Crosby's or clamps. Wire rope clips are used to make a loop at the end of wire rope.

- Crosby "U-Bolt" style clips consists of a U-shaped bolt, a forged saddle and two nuts (see Figure 1 & 2).
- Crosby Fist Grip® clips consists of two saddles and two nuts (see Figures 3 & 4).
- Malleable clips consist of a U-shaped bolt, an inferior cast iron saddle and two nuts.

It is worth noting that Crosby does not manufacturer cast malleable clips. **(IMPORTANT – Only the forged clips can be used for the critical applications such as guying, tie down and suspension.)**

**WIRE ROPE CLIP TYPES  
CRITICAL APPLICATIONS**

**FIST GRIP**

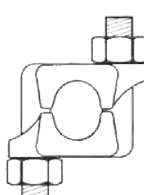

**FORGED U-BOLT**

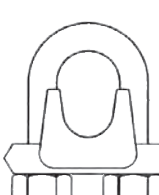

**MALLEABLE**



**“WIRE ROPE CLIPS SHALL BE DROP-FORGED STEEL OF SINGLE SADDLE (U-BOLT) OR DOUBLE SADDLE CLIP. MALLEABLE CAST IRON CLIPS SHALL NOT BE USED.”**

(POH651AA) ASME B30.5

## Key Facts About Wire Rope Clips

1. The proper performance of forged clips depends on proper manufacturing practices that include good forging techniques and accurate machining.
2. Forged clips ("U-bolt" and Fist Grip® styles) provide a greater rope bearing surface and more consistent strength than malleable cast iron clips.
3. Fist Grip® clips provide a saddle for both the "live" and the "dead end."
4. Fewer forged clips ("U-bolt" and Fist Grip® styles) are required for each termination than with malleable cast iron clips.
5. Forged clips ("U-bolt" and Fist Grip® styles) reduce the possibility of hidden defects that are sometimes present in malleable cast iron clips.
6. Malleable cast iron clips should only be used in non-critical applications. ASME, OSHA, and ASTM recommend only forged clips for critical applications.
7. All Clips are individually bagged or tagged with proper application instructions and warning information. User must become familiar with instructions attached to the product.
8. \*Crosby wire rope clips can be reused after careful inspection of threads and saddle area. Proper torque values must be attained whenever Crosby clips are reused. The U-bolt must fit into the base without requiring a forceful change in U-bolt spread. The clip assembly must be properly installed and capable of being torqued to its full recommended value. The roddles in the clip base must be undamaged and the clip assembly must be re-torqued after the initial load is applied.
9. Whenever possible, use thimbles when forming eyes with wire rope clips. Wire rope thimbles were designed to provide the wire rope with protection against wear. They are not considered a primary load carrying member and are not rated by a load carrying capacity.

## Efficiency

Efficiency ratings for wire rope end terminations are based upon the minimum breaking force of wire rope.

Eyes formed in wire rope using properly installed clips have the following efficiency rating.

Wire Rope Size	Efficiency
1/8" through 7/8"	80%
1" through 3-1/2"	90%

# Wire Rope Clip Information

The efficiency of the termination depends on:

1. Selection of the proper size clips
2. Utilizing the proper number of clips
3. Utilizing the proper amount of rope turned back
4. Correct placement of the clips
5. Applying the proper torque to the nuts

It is important to recognize that efficiency cannot be increased by adding extra clips, but it can be reduced by over tightening.

## Standard Considerations When Utilizing Clips

### OSHA 1025.251(c) 4 (iii)

Eyes in wire rope bridles, slings, or bull wires shall not be formed by wire rope clips or knots.

### ASME B30.9

The use of wire rope clips to fabricate wire rope slings is generally prohibited. See ASME B30.9 for full details.

### ANSI A17.1 AND ANSI A10.4.

For elevator, personnel hoist, and scaffold applications, refer to ANSI A17.1 and ANSI A10.4. These standards do not recommend U-Bolt style clips.

## Maritime

The maritime standards are divided into the following categories: Ship Repairing, Shipbuilding, Ship Breaking, Longshoring, and Gear Certification (Vessel Gear and Shore-Based Gear). The use of wire rope clips to form eyes in wire rope and wire rope slings is allowed in Ship Repairing, Shipbuilding and Ship Breaking. In Longshoring Subpart F 1918.52 "Specific requirements" (a)(2) reads, "Wire rope clips or knots shall not be used to form eyes in or join sections of, preventer guys." Also, 1918.52 "Specific Requirements" (c)(3) reads, "Eyes in the ends of wire rope cargo falls shall not be formed by knots and in single part falls, shall not be formed by wire rope clips." In gear certification Subpart D 1919.24 "Limitations on use of wire rope" (c) reads, "Eyes in the ends of wire rope cargo falls shall not be formed by knots and in single part falls, shall not be formed by wire rope clips."

### ASME B30.26

Saddles shall be forged steel.

Each wire rope clip saddle shall have forged or die stamped markings by the manufacturer to show

1. Name or trademark of manufacturer
2. Size

Crosby clips exceed ASME B30.26 identification requirements.

Shock loading should be avoided per ASME B30.26.

See ASME B30.26 for full information.

# Forged Wire Rope Clips



**SEE APPLICATION AND WARNING INFORMATION**

Para Español: [www.thecrosbygroup.com](http://www.thecrosbygroup.com)

on Page 118

## G-450



- Each base has a Product Identification Code (PIC) for material traceability, the name CROSBY or CG, and a size forged into it.
- Based on the catalog breaking strength of wire rope, Crosby wire rope clips have an efficiency rating of 80% for 1/8" - 7/8" sizes, and 90% for sizes 1" through 3-1/2".
- Entire clip - Galvanized to resist corrosive and rusting action.
- Sizes 1/8" through 2-1/2" and 3" have forged bases.
- All clips are individually bagged or tagged with proper application instructions and warning information.
- Clip sizes up through 1-1/2" have rolled threads.
- Meets or exceeds all requirements of ASME B30.26 including identification, ductility, design factor, proof load and temperature requirements. Importantly, these wire rope clips meet other critical performance requirements including fatigue life, impact properties and material traceability, not addressed by ASME B30.26.
- Look for the Red-U-Bolt®, your assurance of Genuine Crosby Clips.

Crosby Clips, all sizes 1/4" and larger, meet the performance requirements of Federal Specification FF-C-450 TYPE 1 CLASS 1, except for those provisions required of the contractor. For additional information, see the Crosby General Catalog.

## G-450 Crosby® Clips

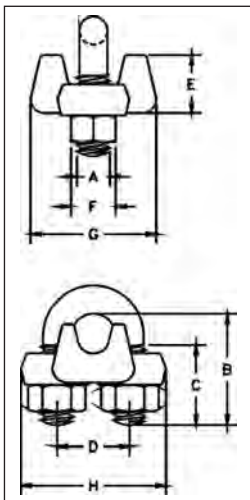

Rope Size		G-450 Stock No.	Std. Package Qty.	Weight Per 100 (lbs.)	Dimensions (in.)							
(in.)	(mm)				A	B	C	D	E	F	G	H
1/8	3-4*	1010015	100	6	.22	.72	.44	.47	.37	.38	.81	.99
3/16*	5*	1010033	100	10	.25	.97	.56	.59	.50	.44	.94	1.18
1/4	6-7	1010051	100	19	.31	1.03	.50	.75	.66	.56	1.19	1.43
5/16	8	1010079	100	28	.38	1.38	.75	.88	.73	.69	1.31	1.66
3/8	9-10	1010097	100	48	.44	1.50	.75	1.00	.91	.75	1.63	1.94
7/16	11	1010113	50	78	.50	1.88	1.00	1.19	1.13	.88	1.91	2.28
1/2	12-13	1010131	50	80	.50	1.88	1.00	1.19	1.13	.88	1.91	2.28
9/16	14-15	1010159	50	109	.56	2.25	1.25	1.31	1.34	.94	2.06	2.50
5/8	16	1010177	50	110	.56	2.25	1.25	1.31	1.34	.94	2.06	2.50
3/4	18-20	1010195	25	142	.62	2.75	1.44	1.50	1.39	1.06	2.25	2.84
7/8	22	1010211	25	212	.75	3.12	1.62	1.75	1.58	1.25	2.44	3.16
1	24-26	1010239	10	252	.75	3.50	1.81	1.88	1.77	1.25	2.63	3.47
1-1/8	28-30	1010257	10	283	.75	3.88	2.00	2.00	1.91	1.25	2.81	3.59
1-1/4	32-34	1010275	10	438	.88	4.44	2.22	2.34	2.17	1.44	3.13	4.13
1-3/8	36	1010293	10	442	.88	4.44	2.22	2.34	2.31	1.44	3.13	4.19
1-1/2	38	1010319	10	544	.88	4.94	2.38	2.59	2.44	1.44	3.41	4.44
1-5/8	41-42	1010337	Bulk	704	1.00	5.31	2.62	2.75	2.66	1.63	3.63	4.75
1-3/4	44-46	1010355	Bulk	934	1.13	5.75	2.75	3.06	2.92	1.81	3.81	5.24
2	48-52	1010373	Bulk	1300	1.25	6.44	3.00	3.38	3.03	2.00	4.44	5.88
2-1/4	56-58	1010391	Bulk	1600	1.25	7.13	3.19	3.88	3.19	2.00	4.56	6.38
2-1/2	62-65	1010417	Bulk	1900	1.25	7.69	3.44	4.13	3.69	2.00	4.69	6.63
** 2-3/4	** 68-72	1010435	Bulk	2300	1.25	8.31	3.56	4.38	4.88	2.00	5.00	6.88
3	75-78	1010453	Bulk	3100	1.50	9.19	3.88	4.75	4.44	2.38	5.31	7.61
** 3-1/2	** 85-90	1010426	Bulk	4000	1.50	10.75	4.50	5.50	6.00	2.38	6.19	8.38

\* Electro-plated U-Bolt and Nuts. \*\* 2-3/4" and 3-1/2" base is made of cast steel.

- Each base has a Product Identification Code (PIC) for material traceability, the name CROSBY or "CG", and a size forged into it.
- Entire clip is made from 316 Stainless Steel to resist corrosive and rusting action.
- All components are Electro-Polished.
- All clips are individually bagged or tagged with proper application instructions and warning information.

## SS-450



## SS-450 Stainless Steel Wire Rope Clips

Rope Size		SS-450 Stock No.	Std. Package Qty.	Weight Per 100 (lbs.)	Dimensions (in.)							
(in.)	(mm)				A	B	C	D	E	F	G	H
1/8	3-4	1011250	Bulk	6	.22	.72	.44	.47	.41	.38	.81	.94
3/16	5	1011261	Bulk	10	.25	.97	.56	.59	.50	.44	.94	1.16
1/4	6-7	1011272	Bulk	20	.31	1.03	.50	.75	.66	.56	1.19	1.44
3/8	9-10	1011283	Bulk	47	.44	1.50	.75	1.00	.91	.75	1.63	1.94
1/2	12-13	1011305	Bulk	77	.50	1.88	1.00	1.19	1.13	.88	1.91	2.28
5/8	16	1011327	Bulk	106	.56	2.38	1.25	1.31	1.34	.94	2.06	2.50

# Wire Rope Clip Information

## U-Bolt Clip Installation Procedures

**WIRE ROPE CLIPS**

**BASIC REQUIREMENTS FOR PROPER TERMINATION**

**SELECT PROPER SIZE CLIPS AND TURNBACK.**

**PLACE CLIPS ON IN PROPER SEQUENCE.**

**TORQUE ALL CLIPS EVENLY WITH A TORQUE WRENCH.**

**APPLY FIRST LOAD AND RE-TORQUE WITH A TORQUE WRENCH.**



← TURNBACK →

(POH651)

Turnback is measured from the end of the rope to the base of the eye or to the thimble. This part of the rope is often referred to as the dead end. Since the U-Bolt Clip has a single saddle, you must be concerned about workers saddling the dead horse.

The table below defines the information required for each wire rope clip to achieve maximum efficiency.

Clip Size (in.)	Rope Size (in.)	Minimum No. of Clips	Amount of Rope to Turn Back in Inches	*Torque in Ft. Lbs.
1/8	1/8	2	3-1/4	4.5
3/16	3/16	2	3-3/4	7.5
1/4	1/4	2	4-3/4	15
5/16	5/16	2	5-1/4	30
3/8	3/8	2	6-1/2	45
7/16	7/16	2	7	65
1/2	1/2	3	11-1/2	65
9/16	9/16	3	12	95
5/8	5/8	3	12	95
3/4	3/4	4	18	130
7/8	7/8	4	19	225
1	1	5	26	225
1-1/8	1-1/8	6	34	225
1-1/4	1-1/4	7	44	360
1-3/8	1-3/8	7	44	360
1-1/2	1-1/2	8	54	360
1-5/8	1-5/8	8	58	430
1-3/4	1-3/4	8	61	590
2	2	8	71	750
2-1/4	2-1/4	8	73	750
2-1/2	2-1/2	9	84	750
2-3/4	2-3/4	10	100	750
3	3	10	106	1200
3-1/2	3-1/2	12	149	1200

If a pulley (sheave) is used for turning back the wire rope, add one additional clip. See Figure 4.

If a greater number of clips are used than shown in the table, the amount of turnback should be increased proportionately.

\* The tightening torque values shown are based upon the threads being clean, dry and free of lubrication.

**STOP**

**NEVER SADDLE A "DEAD HORSE"**

NEVER PLACE "U-BOLT" OVER THE LIVE LINE

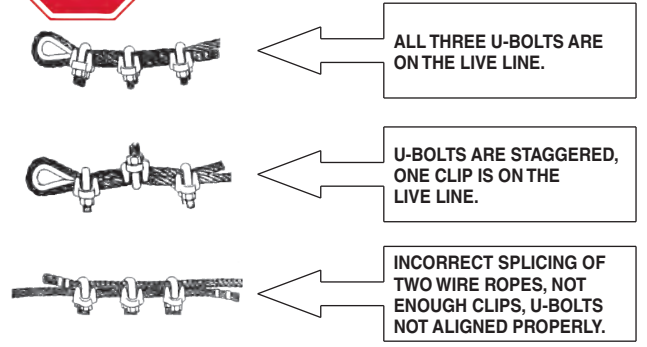

← ALL THREE U-BOLTS ARE ON THE LIVE LINE.

← U-BOLTS ARE STAGGERED, ONE CLIP IS ON THE LIVE LINE.

← INCORRECT SPLICING OF TWO WIRE ROPES, NOT ENOUGH CLIPS, U-BOLTS NOT ALIGNED PROPERLY.

(POH704)

The following example illustrates the correct use of Table 1 in determining the proper application of Crosby G-450 Red U-BOLT Clips.

Example: An installation requires the use of 3/8" 6 x 19 RRL, IPS wire rope.

From Table 1:

- Clip Size = 3/8"
- Number of Clips = 2
- Amount of Turnback = 6-1/2"
- Torque in Ft. Lbs. = 45

Clip Size (in.)	Rope Size (in.)	Minimum No. of Clips	Amount of Rope to Turn Back in Inches	*Torque in Ft. Lbs.
1/8	1/8	2	3-1/4	4.5
3/16	3/16	2	3-3/4	7.5
1/4	1/4	2	4-3/4	15
5/16	5/16	2	5-1/4	30
3/8	3/8	2	6-1/2	45
7/16	7/16	2	7	65

# CROSBY® CLIPS

## WARNINGS AND APPLICATION INSTRUCTIONS



**⚠ WARNING**

- **Failure to read, understand, and follow these instructions may cause death or serious injury.**
- **Read and understand these instructions before using clips.**
- **Match the same size clip to the same size wire rope.**
- **Prepare wire rope end termination only as instructed.**
- **Do not use with plastic coated wire rope.**
- **Apply first load to test the assembly. This load should be of equal or greater weight than loads expected in use. Next, check and retighten nuts to recommended torque (See Table 1, this page).**

Efficiency ratings for wire rope end terminations are based upon the catalog breaking strength of wire rope. The efficiency rating of a properly prepared loop or thimble-eye termination for clip sizes 1/8" through 7/8" is 80%, and for sizes 1" through 3-1/2" is 90%.

The number of clips shown (see Table 1) is based upon using RRL or RLL wire rope, 6 x 19 or 6 x 36 Class, FC or IWRC; IPS or XIP, XXIP. If Seale construction or similar large outer wire type construction in the 6 x 19 Class is to be used for sizes 1 inch and larger, add one additional clip. If a pulley (sheave) is used for turning back the wire rope, add one additional clip.

The number of clips shown also applies to rotation-resistant RRL wire rope, 8 x 19 Class, IPS, XIP, XXIP sizes 1-1/2 inch and smaller; and to rotation-resistant RRL wire rope, 19 x 7 Class, IPS, XIP, XXIP sizes 1-3/4 inch and smaller.

For other classes of wire rope not mentioned above, we recommend contacting Crosby Engineering to ensure the desired efficiency rating.

For elevator, personnel hoist, and scaffold applications, refer to ANSI A17.1 and ANSI A10.4. These standards do not recommend U-Bolt style wire rope clip terminations. The style wire rope termination used for any application is the obligation of the user.

**For OSHA (Construction) applications, see OSHA 1926.251.**

1. Refer to Table 1 in following these instructions. Turn back specified amount of rope from thimble or loop.



Apply first clip one base width from dead end of rope. Apply U-Bolt over dead end of wire rope – live end rests in saddle (Never saddle a dead horse!). Use torque wrench to tighten evenly, alternate from one nut to the other until reaching the recommended torque.

2. When two clips are required, apply the second clip as near the loop or thimble as possible. Use torque wrench to tighten evenly, alternating until reaching the recommended torque. When more than two clips are required, apply the second clip

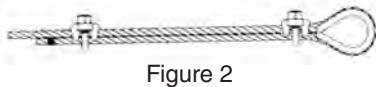

as near the loop or thimble as possible, turn nuts on second clip firmly, but do not tighten. Proceed to Step 3.

3. When three or more clips are required, space additional clips equally between first two – take up rope slack – use torque wrench to tighten nuts on each U-Bolt evenly, alternating from one nut to the other until reaching recommended torque.



4. If a pulley (sheave) is used in place of a thimble, add one additional clip. Clip spacing should be as shown.

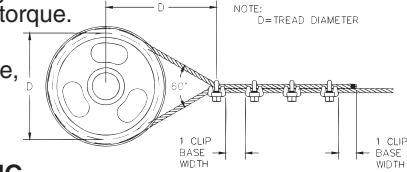

### 5. WIRE ROPE SPLICING PROCEDURES:

The preferred method of splicing two wire ropes together is to use inter-locking turnback eyes with thimbles, using the recommended number of clips on each eye (See Figure 5).

An alternate method is to use twice the number of clips as used for a turnback termination. The rope ends are placed parallel to each other, overlapping by twice the turnback amount shown in the application instructions. The



minimum number of clips should be installed on each dead end (See Figure 6). Spacing, installation torque, and other instructions still apply.

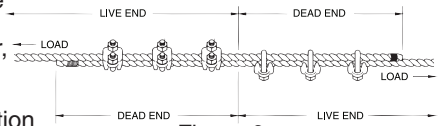

### 6. IMPORTANT

Apply first load to test the assembly. This load should be of equal or greater weight than loads expected in use. Next, check and use torque wrench to retighten to recommended torque. In accordance with good rigging and maintenance practices, the wire rope end termination should be inspected periodically for wear, abuse, and general adequacy.

Clip Size (in.)	Rope Size (in.)	Minimum No. of Clips	Amount of Rope to Turn Back in Inches	* Torque in Ft.Lbs.
1/8	1/8	2	3-1/4	4.5
3/16	3/16	2	3-3/4	7.5
1/4	1/4	2	4-3/4	15
5/16	5/16	2	5-1/4	30
3/8	3/8	2	6-1/2	45
7/16	7/16	2	7	65
1/2	1/2	3	11-1/2	65
9/16	9/16	3	12	95
5/8	5/8	3	12	95
3/4	3/4	4	18	130
7/8	7/8	4	19	225
1	1	5	26	225
1-1/8	1-1/8	6	34	225
1-1/4	1-1/4	7	44	360
1-3/8	1-3/8	7	44	360
1-1/2	1-1/2	8	54	360
1-5/8	1-5/8	8	58	430
1-3/4	1-3/4	8	61	590
2	2	8	71	750
2-1/4	2-1/4	8	73	750
2-1/2	2-1/2	9	84	750
2-3/4	2-3/4	10	100	750
3	3	10	106	1200
3-1/2	3-1/2	12	149	1200

If a pulley (sheave) is used for turning back the wire rope, add one additional clip. See Figure 4.

If a greater number of clips are used than shown in the table, the amount of turnback should be increased proportionately.

\*The tightening torque values shown are based upon the threads being clean, dry, and free of lubrication.

# Fist Grip® Wire Rope Clips



**SEE APPLICATION AND WARNING INFORMATION**

Para Español: [www.thecrosbygroup.com](http://www.thecrosbygroup.com)

on Page 121

## NEW STYLE FIST GRIP® CLIPS 3/16" - 5/8"



Fist Grip® wire clips meet or exceed the performance requirements of Federal Specification FF-C-450 Type III, Class 1, except for those provisions required of the contractor. For additional information, see Crosby General Catalog.

- Entire clip is galvanized to resist corrosive and rusting action.
- Based on the catalog breaking strength of wire rope, Crosby wire rope clips have an efficiency rating of 80% for 3/16" - 7/8" sizes, and 90% for sizes 1" through 1-1/2".
- Bolts are an integral part of the saddle. Nuts can be installed in such a way as to enable the operator to swing the wrench in a full arc for fast installation.
- All sizes have forged steel saddles.
- All clips are individually bagged or tagged with proper application instructions and warning information.
- Meets or exceeds all requirements of ASME B30.26 including identification, ductility, design factor, proof load and temperature requirements. Importantly, these wire rope clips meet other critical performance requirements including fatigue life, impact properties and material traceability, not addressed by ASME B30.26.
- Assembled with standard heavy hex nuts.

## FIST GRIP® CLIPS 3/4" - 1-1/2"



## G-429 Fist Grip® Clips

Rope Size		G-429 Stock No.	Std. Package Qty.	Weight Per 100 (lbs.)	Dimensions (in.)				
(in.)*	(mm)				C	D	E	G	N
3/16 - 1/4	5-7	1010471	100	23	.40	.94	.38	1.41	1.44
5/16	8	1010499	100	28	.47	1.06	.38	1.50	1.54
3/8	10	1010514	50	40	.51	1.06	.44	1.84	1.78
7/16 - 1/2	11-13	1010532	50	62	.59	1.25	.50	2.21	2.15
9/16 - 5/8	14-16	1010550	50	103	.72	1.50	.63	2.72	2.57
3/4	18-20	1010578	25	175	.86	1.81	.75	2.94	2.67
7/8	22	1010596	25	225	.97	2.12	.75	3.31	2.86
1	24-26	1010612	10	300	1.13	2.25	.75	3.72	3.06
1-1/8	28-30	1010630	10	400	1.28	2.38	.88	4.22	3.44
1-1/4	32-34	1010658	10	400	1.34	2.50	.88	4.25	3.56
1-3/8 - 1-1/2	36-40	1010676	Bulk	700	1.56	3.00	1.00	5.56	4.12

\* Sizes through 5/8" incorporate New Style Design.

### 3/16" - 5/8"

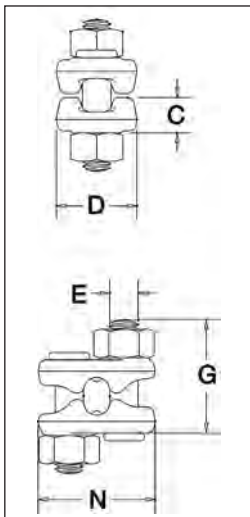

### 3/4" - 1-1/2"

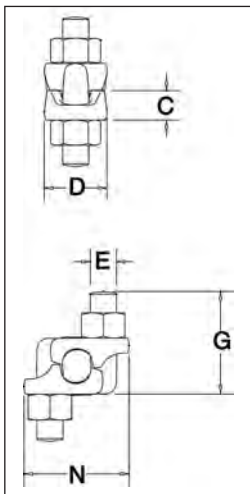

# Wire Rope Clip Information

## Fist Grip® Clip Installation Procedures

**WIRE ROPE CLIPS**

**BASIC REQUIREMENTS FOR PROPER TERMINATION**

**SELECT PROPER SIZE CLIPS AND TURNBACK.**

**PLACE CLIPS ON IN PROPER SEQUENCE.**

**TORQUE ALL CLIPS EVENLY WITH A TORQUE WRENCH.**

**APPLY FIRST LOAD AND RE-TORQUE WITH A TORQUE WRENCH.**

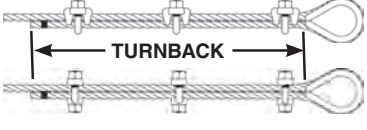

(POH651)

Turnback is measured from the end of the rope to the base of the eye or to the thimble. This part of the rope is often referred to as the dead end or “dead horse.” Since the Fist Grip® clip utilizes two saddles, you do not have to be concerned with workers saddling the dead horse.

The table below defines the information required for each wire rope clip to achieve maximum efficiency.

The following example illustrates the correct use of Table 1 in determining the proper application of Crosby G-429 Fist Grip® Clips.

Example: An installation requires the use of 7/16” 6 x 19 RRL, IPS wire rope.

- From Table 1:
- Clip Size = 7/16”
  - Number of Clips = 2
  - Amount of Turnback = 6-1/2”
  - Torque in Ft. Lbs. = 65

Clip Size (in.)	Rope Size (in.)	Minimum No. of Clips	Amount of Rope to Turn Back in Inches	*Torque in Ft. Lbs.
3/16	3/16	2	4	30
1/4	1/4	2	4	30
5/16	5/16	2	5	30
3/8	3/8	2	5-1/4	45
7/16	7/16	2	6-1/2	65

Clip Size (in.)	Rope Size (in.)	Minimum No. of Clips	Amount of Rope to Turn Back in Inches	*Torque in Ft. Lbs.
3/16	3/16	2	4	30
1/4	1/4	2	4	30
5/16	5/16	2	5	30
3/8	3/8	2	5-1/4	45
7/16	7/16	2	6-1/2	65
1/2	1/2	3	11	65
9/16	9/16	3	12-3/4	130
5/8	5/8	3	13-1/2	130
3/4	3/4	3	16	225
7/8	7/8	4	26	225
1	1	5	37	225
1-1/8	1-1/8	5	41	360
1-1/4	1-1/4	6	55	360
1-3/8	1-3/8	6	62	500
1-1/2	1-1/2	7	78	500

If a pulley (sheave) is used for turning back the wire rope, add one additional clip. See Figure 4.

If a greater number of clips are used than shown in the table, the amount of turnback should be increased proportionately.

\* The tightening torque values shown are based upon the threads being clean, dry and free of lubrication.

# CROSBY® FIST GRIP® CLIPS

## WARNINGS AND APPLICATION INSTRUCTIONS



New Style Fist Grip®  
3/16" - 5/8"



Fist Grip® Clips  
3/4" - 1-1/2"

### WARNING

- Failure to read, understand, and follow these instructions may cause death or serious injury.
- Read and understand these instructions before using clips.
- Match the same size clip to the same size wire rope.
- Do not mismatch Crosby clips with other manufacturer's clips.
- Prepare wire rope end termination only as instructed.
- Do not use with plastic coated wire rope.
- Apply first load to test the assembly. This load should be of equal or greater weight than loads expected in use. Next, check and retighten nuts to recommended torque (See Table 1, this page).

Efficiency ratings for wire rope end terminations are based upon the catalog breaking strength of wire rope. The efficiency rating of a properly prepared loop or thimble-eye termination for clip sizes 1/8" through 7/8" is 80%, and for sizes 1" through 3-1/2" is 90%.

The number of clips shown (see Table 1) is based upon using RRL or RLL wire rope, 6 x 19 or 6 x 37 Class, FC or IWRC; IPS or XIP, XXIP. If Seale construction or similar large outer wire type construction in the 6 x 19 Class is to be used for sizes 1 inch and larger, add one additional clip. If a pulley (sheave) is used for turning back the wire rope, add one additional clip.

The number of clips shown also applies to rotation-resistant RRL wire rope, 8 x 19 Class, IPS, XIP, XXIP sizes 1-1/2 inch and smaller; and to rotation-resistant RRL wire rope, 19 x 7 Class, IPS, XIP, XXIP sizes 1-3/4 inch and smaller.

For other classes of wire rope not mentioned above, we recommend contacting Crosby Engineering at the address or telephone number on the back cover to ensure the desired efficiency rating.

The style of wire rope termination used for any application is the obligation of the user.

The style wire rope termination used for any application is the obligation of the user.

**For OSHA (Construction) applications, see OSHA 1926.251.**

1. Refer to Table 1 in following these instructions. Turn back specified amount



Figure 1

of rope from thimble or loop. Apply first clip one base width from dead end of rope. Use torque wrench to tighten evenly, alternating from one nut to the other until reaching the recommended torque.

2. When two clips are required, apply the second clip as near the loop or thimble as possible. Use torque



Figure 2

wrench to tighten evenly, alternating until reaching the recommended torque. When more than two clips are required, apply the second clip as near the loop or thimble as possible, turn nuts on second clip firmly, but do not tighten. Proceed to Step 3.

3. When three or more clips are required, space additional clips equally between first two – take up rope slack – use torque wrench to tighten on each Clip evenly, alternating from one nut to the other until reaching recommended torque.

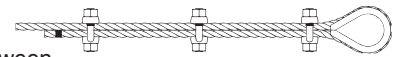

Figure 3

4. If a pulley (sheave) is used in place of a thimble, add one additional Fist Grip. Fist Grip spacing should be as shown.

### 5. WIRE ROPE SPLICING PROCEDURES:

The preferred method of splicing two wire ropes together is to use inter-locking turnback eyes with thimbles, using the recommended number of clips on each eye (See Figure 5).

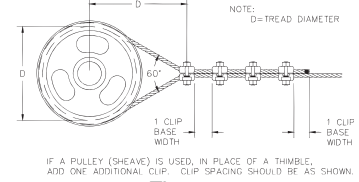

Figure 4

An alternate method is to use twice the number of clips as used for a turnback termination. The rope ends are placed parallel to each other, overlapping by twice the turnback amount shown in the application instructions.



Figure 5

The minimum number of clips should be installed on each dead end (See Figure 6). Spacing, installation torque, and other instructions still apply.

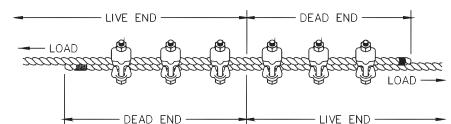

Figure 6

### 6. IMPORTANT

Apply first load to test the assembly. This load should be of equal or greater weight than loads expected in use. Next, check and use torque wrench to retighten to recommended torque.

In accordance with good rigging and maintenance practices, the wire rope end termination should be inspected periodically for wear, abuse, and general adequacy.

Clip Size (in.)	Rope Size (in.)	Minimum No. of Clips	Amount of Rope to Turn Back in Inches	* Torque in Ft.Lbs.
3/16	3/16	2	4	30
1/4	1/4	2	4	30
5/16	5/16	2	5	30
3/8	3/8	2	5-1/4	45
7/16	7/16	2	6-1/2	65
1/2	1/2	3	11	65
9/16	9/16	3	12-3/4	130
5/8	5/8	3	13-1/2	130
3/4	3/4	3	16	225
7/8	7/8	4	26	225
1	1	5	37	225
1-1/8	1-1/8	5	41	360
1-1/4	1-1/4	6	55	360
1-3/8	1-3/8	6	62	500
1-1/2	1-1/2	7	78	500

If a pulley (sheave) is used for turning back the wire rope, add one additional clip. See Figure 4.

If a greater number of clips are used than shown in the table, the amount of turnback should be increased proportionately.

\*The tightening torque values shown are based upon the threads being clean, dry, and free of lubrication.

# Notes

---

# Notes

---



# The following services are available through the Crosby **EndTerminationSupport**<sup>®</sup> program.

## Inspection/Maintenance Services

At the standard day rates, the following inspection and maintenance services can be provided to your business by our factory trained technician.

- *Thorough inspection of National swaging machines.*
- *Thorough inspection of National Swage dies, with installation of RFID record keeping and documentation technology.*
- *Maintenance services for National swaging machines.*

## Training

While at your facility, we can also provide training to your employees in the following areas at no additional cost.

- *Swaging training, with certificates.*
- *Socketing and Wirelock<sup>®</sup> training with certificates.*



## Why is the Crosby **EndTerminationSupport**<sup>®</sup> Program important to you?

- **Inspection.** *Your business, as a company that focuses on the supply of wire rope slings and assemblies, depends on having swaging machines and swaging dies that are regularly inspected and properly maintained to ensure that they perform as expected.*
- **Maintenance.** *Down time, reduced production and unscheduled maintenance cost your company money.*
- **Training.** *The specialized nature of the wire rope products that you manufacture requires that you employ a well trained and highly knowledgeable team of riggers. Properly “factory trained” operators will result in improved efficiencies.*

# Crosby<sup>®</sup>

[www.thecrosbygroup.com](http://www.thecrosbygroup.com)

### Corporate Office

2801 Dawson Road  
Tulsa, OK 74110  
P: (918) 834-4611  
F: (918) 832-0940  
[crosbygroup@thecrosbygroup.com](mailto:crosbygroup@thecrosbygroup.com)

### Canada

3660 Odyssey Dr, Unit 4  
Mississauga, Ontario  
Canada L5M 0Y9  
P: (877) 462-7672  
F: (877) 260-5106  
[sales@crosby.ca](mailto:sales@crosby.ca)

### Europe

Industriepark Zone b N°26  
2220 Heist-op-den-Berg  
Belgium  
P: (+32) (0)15 75 71 25  
F: (+32) (0)15 75 37 64  
[sales@crosbyeurope.com](mailto:sales@crosbyeurope.com)

