

Shipbuilding Clamps: Bulbprofiles

IPBUZ

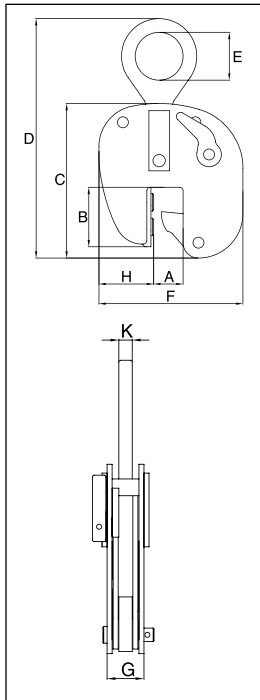

The IPBUZ shipbuilding clamps are used for the lifting, transfer and placing of bulb profiles onto ship's hulls perpendicularly. These clamps are fitted with a locking device for both open and closed positions, which ensures complete reliability. They are to be used exclusively for bulb profiles (not for plates).



For the lifting, transfer and placing of Bulb Profiles onto Ship's Hulls Perpendicularly

- Available in capacities of .75 thru 3.75 metric tons.
- Jaw openings available: HP 120mm to HP 430mm.
- Welded alloy steel body for strength and smaller size. Forged alloy components, where required.
- Individually Proof Tested to 2 times the Working Load Limit with certification.
- Company name (CrosbyIP), logo, Working Load Limit and jaw opening permanently stamped on body.
- Each product is individually serialized, with the serial number and Proof Load test date stamped on body. Serial number is included on the test certificate with maintenance and warranty logbook.
- Optional IP-5000 Stinger assembly available (see page 420). Allows for easy connection between the clamp and hoist hook.
- Maintenance replacement parts are available.
- Manufactured by a ISO 9001 facility.
- All sizes are **RFID EQUIPPED**.



Load Rated

Model IPBUZ: with Universal Hoisting Eye Model IPBUZ: with Fixed Hoisting Eye

Model	Working Load Limit (t)*	Stock No.	Weight Each (kg.)	Dimensions (mm)								
				Jaw A	B	C	D	E	F	G	H	K
IPBUZ	.75	2705601	8.5	HP 120-200	85	226	390	70	210	61	70	16
With fixed hoisting eye												
IPBUZ	.75	2705600	7.0	HP 120-200	85	226	390	70	210	61	70	16
IPBUZ	1.5	2705701	15.0	HP 220-430	196	397	568	70	256	69	48	16
IPBUZ	3.75	2705702	28.5	HP 220-430	238	438	565	80	355	64	100	20

* Design Factor based on EN 13155 and ASME B30.20.

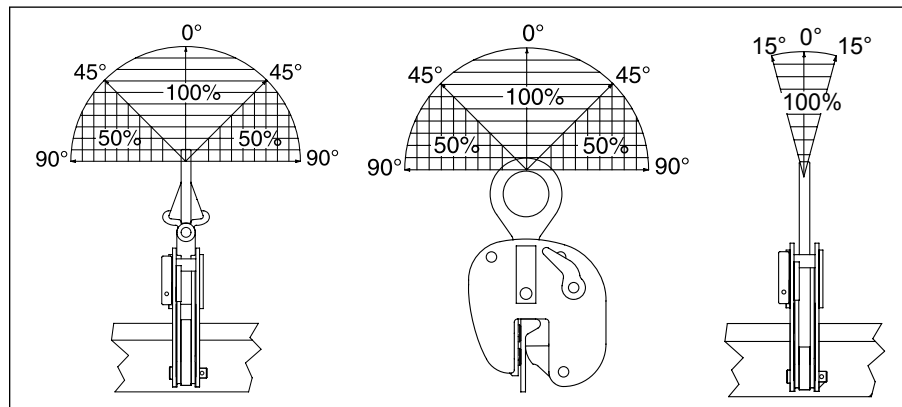

Crosby Lifting Clamps