

CROSBY Clamp-Co® Barrier / Curb Grabs



CCBG

Crosby Clamp-Co® Barrier Grabs provide a fast and efficient method for handling concrete road barriers.

- Hands-free operation.
- Alloy Steel Construction.
- Comes equipped with polyurethane pads. (Replacement kits available).
- Eliminates the need for slings, chokers and spreader bars.
- Individually Proof Tested to 2 times the Working Load Limit with certification .
- Finish - Red Paint.
- All sizes are **RFID EQUIPPED**.

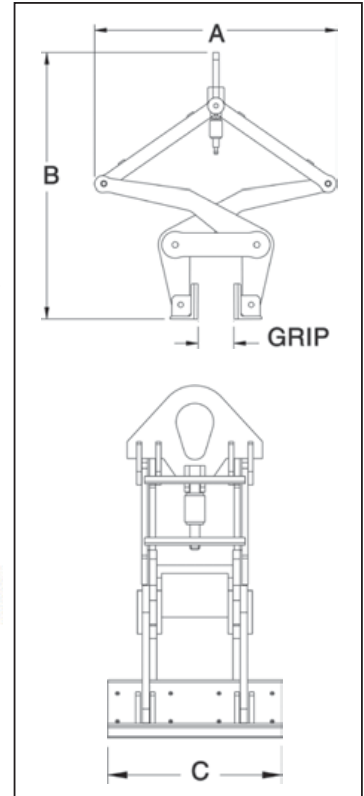

Barrier Grab

Model No.	CCBG-150 Stock No.	Working Load Limit (Tons)*	Weight Each (lb)	Grip Width (in)	Dimensions (in)		
					A	B	C
BG-9000	2734009	4.5	290	6 (min.)	40.88	44.88	18.00
				12 (max.)	44.00	36.75	18.00

* Design factor based on EN13155 and ASME B30.20.



CCCG

Crosby Clamp-Co® Curb Grabs provide a fast and efficient method for handling large granite curbs.

- Virtually no manual assistance is required.
- Alloy Steel Construction.
- Available with polyurethane pads or hardened steel jaw. (Replacement kits available).
- Eliminates the need for slings, chokers and spreader bars.
- Individually Proof Tested to 2 times the Working Load Limit with certification .
- Finish - Red Paint.
- All sizes are **RFID EQUIPPED**.

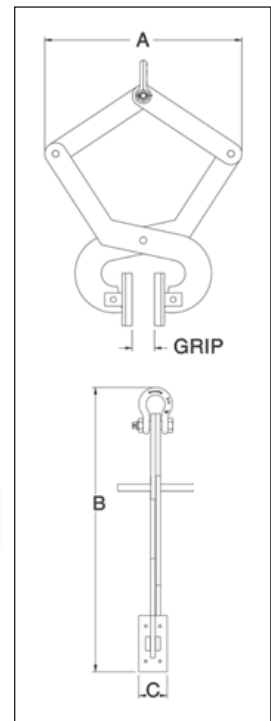

Curb Grab

Model No.	CCGG-140 StockNo.	Working Load Limit (lb)*	WeightEach (lb)	Grip Width (in)	Dimensions (in)		
					A	B	C
CG-1400	2734000	1400	370	4 (min.)	22.5	27.25	3.00
				7 (max.)	25.0	20.25	3.00

* Design factor based on EN13155 and ASME B30.20.