

Lebus® Load Binders



Load Rated



SEE APPLICATION AND WARNING INFORMATION

Para Español: www.thecrosbygroup.com

On Page 246

A-1W



- Forged steel – Quenched and Tempered.
- Used as a come-a-long for short take-up on chain.
- Binder toggles away from the load.

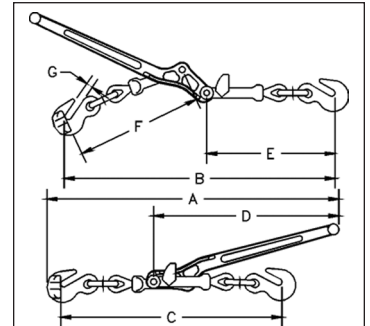

A-1W Walking Load Binders

- Meets or exceeds requirements of US DOT FMCSA Part 393 Subpart I.

Model	Stock No.	Chain Size (in.)	Working Load Limit (lbs.)	Proof Load (lbs.)	Ultimate Load (lbs.)	Weight Each (lbs.)	Handle Length (in.)	Dimensions (in.)						
								A	B	C	D	E	F	G
A-1W	1048388	1/2 only	9200	18400	33000	13.10	18.69	28.75	25.75	21.25	18.69	12.31	12.38	.63

R-10

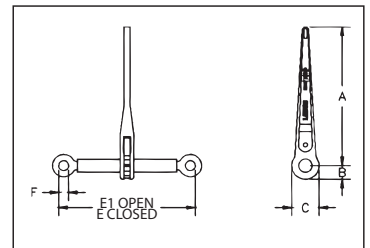

R-10 Binder without Links and Hooks

- Meets or exceeds requirements of US DOT FMCSA Part 393 Subpart I.

Model	R-10 Stock No.	Working Load Limit (lbs.)*	Weight Each (lbs.)	Handle Length (in.)	Barrel Length (in.)	Take Up (in.)	Dimensions (in.)					
							A	B	C	E	E1	F
R-10	1048468	16000	8.04	14	10	8.0	14	1.38	2.75	14	22	1.00

* Ultimate Load is 3 times the Working Load Limit.

Chain & Accessories