

Pivot Hoist Rings

Load Rated

**HR-100 UNC
HR-100M METRIC**



- Forged bail provides the following:
 - Easily readable “Raised Lettering” showing the name Crosby or “CG” and PIC code for material traceability.
 - More durability provides the increased “Toughness” desired in potentially abusive field conditions.
 - Larger opening than standard Hoist Ring bails.
- 180 degree pivot action at full capacity.
- Bolts included as part of assembly.
- Design Factor of 5 to 1.
- Individually Proof Tested to 2-1/2 times Working Load Limit.
- UNC Bolt specification is a Grade 8 Alloy socket head cap screw to ASTM A 574.
- Metric Bolt specification is a Grade 12.9 Alloy socket head cap screw to DIN 912.
- Frame 2 and larger are **RFID EQUIPPED**.



**SEE APPLICATION AND
WARNING INFORMATION**

Para Español: www.thecrosbygroup.com

On Page 182-183

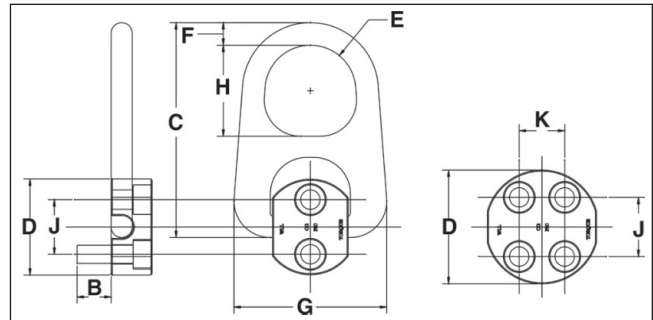

HR-100 Pivot Hoist Rings Coil Threads

Frame Size No.	HR-500 Stock No.	Working Load Limit (lbs)*	Torque in Ft-Lbs.	No. of Bolts	Weight Each (lbs.)	Dimensions (in)									
						Bolt Size "A"	Effective Thread Projection Length B	C	Diameter D	Radius E	F	G	H	J	K
1	1067408	2000	7	2	.6	5/16-18 x 1.25	.82	3.43	2.00	.62	.44	2.27	1.38	1.00	-
2	1067417	2500	12	2	3.1	3/8-16 x 1.25	.65	6.03	2.25	1.25	.75	4.20	2.50	1.13	-
2	1067426	5000	28	2	3.3	1/2-13 x 2.00	1.40	6.03	2.63	1.25	.75	4.20	2.50	1.50	-
3	1067435	12000	28	4	10.5	1/2-13 x 2.75	1.65	8.27	3.13	1.63	1.00	6.25	3.25	1.63	1.25
4	1067444	20000	60	4	22.0	5/8-11 x 3.25	1.65	10.63	4.47	2.00	1.25	7.82	4.00	2.06	1.25

*Ultimate Load is 5 times the Working Load Limit.

HR-100M Pivot Hoist Rings Metric Threads

Frame Size No.	HR-100M Stock No.	Working Load Limit (kg)*	Torque in Nm	No. of Bolts	Weight Each (kg.)	Dimensions (mm)									
						Bolt Size "A"	Effective Thread Projection Length B	C	Diameter D	Radius E	F	G	H	J	K
1	1067905	900	10	2	.3	M8-1.25 x 30	19.1	87.1	51.0	15.8	11.2	57.7	35.1	25.4	-
2	1067914	1150	16	2	1.4	M10-1.50 x 30	14.8	153	57.2	31.8	19.1	107	63.5	28.6	-
2	1067923	2150	38	2	1.5	M12-1.75 x 50	34.8	153	66.8	31.8	19.1	107	63.5	38.1	-
3	1067932	5100	38	4	4.8	M12-1.75 x 70	42.1	210	79.5	41.4	25.4	159	82.6	41.3	31.8
4	1067941	9000	81	4	10.0	M16-2.00 x 80	39.4	270	114	51.0	31.8	199	102	52.4	31.8

*Ultimate Load is 5 times the Working Load Limit.